



NAZARBAYEV
UNIVERSITY

School of Engineering and Digital Sciences

Bachelor of Engineering in
Mechanical and Aerospace Engineering

**FDM printability of recycled material:
Investigation of mechanical properties and
surface characteristics**

(Final Capstone Project Report)

by

Isakhan Nazhimidin, Inabbat Torebekkyzy

Lead Supervisor: Prof. Asma Perveen

Co-Supervisor: Prof. Didier Talamona

May, 2025

Declaration

We, Isakhan Nazhimidin, Inabbat Torebekkyzy, hereby declare that this report, entitled “FDM printability of recycled material: Investigation of mechanical properties and surface characteristics ” is the result of our own project work except for quotations and citations which have been duly acknowledged. We also declare that it has not been previously or concurrently submitted for any other degree at Nazarbayev University or elsewhere.

Signature: Isakhan Nazhimidin Inabbat Torebekkyzy

Date: May 7, 2025

Abstract

The main objectives of this study are to investigate the effect FDM 3D printing with different parameters on mechanical properties of the material and to investigate the effect of recycling and reuse of the material on its mechanical characteristics. The project consists of cyclical experimental testing and recycling, the results of which are analyzed using the Taguchi method. The material for the research is a polylactic acid, also known as PLA, and the focused printing parameters are infill pattern, infill density and extrusion temperature. For infill pattern triangular, tri-hexagonal and octet shapes were investigated and for infill density and printing temperature 40,60,80 percent and 190,200,210°C were taken correspondingly. For design of the experiment the L9orthogonal array Taguchi method was used, resulting in total of 9 samples. After printing, specimens underwent through tensile, hardness and bending tests on the corresponding equipment. After, the material was recycled - the tested specimen were then shredded, palletized and then extruded as a new filament. The recycled PLA went through the same tests and after that the material was recycled and tested again. All in all, 3 runs of experiment were conducted for virgin PLA and for 2 iterations of recycling. Overall, according to results, the optimal printing parameters for the virgin material were 80 percent infill density, 200°C extrusion temperature and tri-hexagonal shape infill pattern. After recycling, tensile and bending properties of the PLA decreased and the effect of the parameters changed. However, with proper printing parameters such as 80 percent infill density, 190°C extrusion temperature and tri-hexagonal shape infill pattern, recycled PLA can give close to the virgin material results of tensile, hardness and bending tests.

Contents

Abstract	iii
Contents	v
List of Figures	vii
List of Tables	ix
1 Introduction	1
1.1	1
1.2 Literature review	2
2 Materials and methods	5
2.1 Specimen design	6
2.2 Design of the experiment	6
2.3 Experimental procedure	7
3 Results and discussion	15
3.1 Tensile test	15
3.2 Vickers hardness test	20
3.3 3 point bending test	27
4 Conclusion	33
Bibliography	35

List of Figures

2.1	The adapted procedure of the experiment	5
2.2	Tensile and bending specimen design	6
2.3	Hardness specimen design	6
2.4	Printing process	8
2.5	Printed specimen	9
2.6	Tensile test	9
2.7	Vickers hardness test	10
2.8	3 point bending test	10
2.9	Shredding machine	11
2.10	Shredded and granulated PLA	11
2.11	Material extrusion	12
2.12	Palletized PLA	12
2.13	Material goes into the extruder	13
2.14	Diameter of the filament	13
2.15	Spool made from filament.	14
3.1	Effect of printing parameters on Young modulus	17
3.2	Effect of printing parameters on yield strength	17
3.3	Effect of printing parameters on ultimate tensile strength	18
3.4	Interaction plots for Young modulus: From left to right - pattern vs density, density vs temperature, temperature vs pattern	19
3.5	Interaction plots for yield strength: From left to right - pattern vs density, density vs temperature, temperature vs pattern	19
3.6	Interaction plots for ultimate tensile strength: From left to right - pattern vs density, density vs temperature, temperature vs pattern	19
3.7	Effect of printing parameters on Young modulus for recycled PLA	21
3.8	Effect of printing parameters on yield strength for recycled PLA	21
3.9	Effect of printing parameters on ultimate tensile strength for recycled PLA	22
3.10	Interaction plots for Young modulus for recycled PLA: From left to right - pattern vs density, density vs temperature, temperature vs pattern	22
3.11	Interaction plots for yield strength for recycled PLA: From left to right - pattern vs density, density vs temperature, temperature vs pattern	22
3.12	Interaction plots for ultimate tensile strength for recycled PLA: From left to right - pattern vs density, density vs temperature, temperature vs pattern	23

3.13	Comparison of Young modulus values for virgin, recycled and re-recycled PLA	23
3.14	Comparison of yield strength values for virgin, recycled and re-recycled PLA	24
3.15	Comparison of ultimate tensile strength values for virgin, recycled and re-recycled PLA	25
3.16	Effect of printing parameters on Vickers hardness	26
3.17	Interaction plots for Vickers hardness: From left to right - pattern vs density, density vs temperature, temperature vs pattern	26
3.18	Effect of printing parameters on Vickers hardness for recycled PLA	27
3.19	Interaction plots for Vickers hardness for recycled PLA: From left to right - pattern vs density, density vs temperature, temperature vs pattern	27
3.20	Comparison of Vickers hardness values for virgin, recycled and re-recycled PLA	28
3.21	Effect of printing parameters on bending strength	29
3.22	Interaction plots for bending strength: From left to right - pattern vs density, density vs temperature, temperature vs pattern	29
3.23	Effect of printing parameters on bending strength for recycled PLA	30
3.24	Interaction plots for bending strength for recycled PLA: From left to right - pattern vs density, density vs temperature, temperature vs pattern	30
3.25	Comparison of Vickers hardness values for virgin, recycled and re-recycled PLA	31

List of Tables

1.1	Printing parameters from previous studies	3
2.1	Printing parameters to be kept constant	5
2.2	Design of the experiment	7
3.1	Results of the experiment	16
3.2	Comparison of mean values of experiment results of tensile test	16
3.3	Comparison of mean values of experiment results of tensile test for recycled PLA	20
3.4	Young modulus values for virgin, recycled and re-recycled PLA	23
3.5	Yield strength values for virgin, recycled and re-recycled PLA	24
3.6	Ultimate tensile strength values for virgin, recycled and re-recycled PLA	24
3.7	Comparison of mean values of experiment results of Vickers hardness test	26
3.8	Vickers hardness values for virgin, recycled and re-recycled PLA	28
3.9	Comparison of mean values of experiment results of 3 point bending test	29
3.10	Bending strength values for virgin, recycled and re-recycled PLA	31

Chapter 1

Introduction

1.1

In recent years, a variety of 3D printing technologies were introduced within the development of it into engineering. One of them is fused deposition modeling (FDM). The process of FDM printing includes exposure of the extruded filament material to high temperature and deposition using the nozzle, while the nozzle moves in a 3-degree direction [1]. After, the nozzle head deposits the polymer in the plate layer by layer to get the desired prototype. FDM is widely used to print detailed functional prototypes, long-lasting manufacturing tools, and small-sized productions, which are utilized in industries such as medicine, aerospace, architecture, and automotive [2]. Moreover, the FDM printed production market size is assessed to be 312 million US dollars in 2022 with an increment up to 533.2 million US dollars by 2031[4]. FDM printing technology is applicable to thermoplastics of high strength such as polycarbonate (PC), polylactic acid (PLA), acrylonitrile butadiene styrene (ABS), polyamide (Nylon) and others. Due to its ease of use, poly(lactic acid) (PLA) is still the most widely used material among the wide variety available for FDM printers, which is chosen for research in this project. This biobased material's biocompatibility and biodegradability are also significant qualities that make it valuable for medical aids as well as tissue engineering and bone repair [1]. Another intriguing feature of PLA is its shape memory, which allows an object to be 3D printed in PLA to be distorted, ideally above the glass transition temperature, and then automatically return to its original shape when heated to a temperature between 60 and 90 °C [3]. Nowadays, plastics contribute to every area of life, they are widely accepted as packaging materials, have a variety of applications in building industry (piping, guttering and conduit, damp course layers, flooring, insulation, wall cladding, and window frames), electrical industry, mainly as insulators, transportation, furniture, industrial equipment and many other [4]. However, the mass usage of plastic leads to the threat of plastic pollution. Considered in a broad context, the potential impacts of accumulating and poorly reversible plastic pollution of the global environment are wide-reaching, encompassing both geophysical and biological impacts, and could put added pressure on ecosystems [5]. For example, a plastic shopping bag can take 1,000 years to decompose. One of the possible solutions to plastic pollution is recycling. At best, less than 10 percent of plastics are recycled worldwide [1] and recycling rates for plastics are increasing in many countries around the world, while an international market for recycled plastics is developing [6]. This

paper by evaluating the mechanical and surface characteristics of printed PLA materials can pave the way for sustainable production practices. The manufacturers and designers can get insights and knowledge about FDM printing from the results of this paper and implement it as soon as possible.

1.2 Literature review

Several researches have been done in the past aiming to study the mechanical surface properties of PLA exposed to recycling and printing. The process parameters that influence FDM printing include infill density, extrusion temperature, nozzle diameter, layer thickness, raster angle, and printing speed. In experimental work done by [7], virgin PLA was extruded into filament and then subjected to FDM 3D printing, his work reveals that the viscosity measurements deteriorated after every FDM printing of PLA, which is due to the increased in carbonyl bonds and crystallinity. Meanwhile, the study of [8] created specimens and investigated the tensile properties of polylactic acid (PLA) material under two different conditions: the printing angle and the raster angle. The findings demonstrated that the tensile characteristics of PLA materials are significantly influenced by the printing and raster angles. The UV curing process increased the PLA material's brittleness and decreased its elongation, which is the cause. In contrast, [3] established that layer thickness is linearly correlated with tensile strength and three-point bending strength. The third study by [2] in contrast has proved that the mechanical properties are influenced not only by process parameters but also by heat after treatment. Ultimately, it was discovered that heat treatment-induced deformation and recovery did not considerably lower the maximum forces. This makes it possible to 3D print orthoses flat and then bend them to fit the appropriate body part. Overall, the literature review is summarized in 1.1.

Though there are scholarly works focused on FDM parameters such as raster angle, printing angle, and extrusion temperature of PLA, ABS, and nylon to examine the tensile strength, bending strength, and viscosity measurements after recycling, the research works are mainly focused on Taguchi methodology to synthesize obtained results. As a result, optimization of PLA bending, and tensile strength, and hardness is poorly reflected in previous papers by remaining parameters(extrusion temperature, infill density, infill pattern). Furthermore, there is quite less investigation conducted on PLA material. Thus, this study aims to study the influence of FDM printing parameters for recycled materials on their properties, such as tensile strength, hardness, bending, and visual characteristics. Particularly, the objections include investigating how samples with diverse infill patterns, temperatures, and infill densities will react to recycling and what changes will be made; and investigating visual changes of samples with diverse infill patterns, temperatures, and infill densities after recycling.

Table 1.1: Printing parameters from previous studies

Tab : 1

Printing parameters/ Articles	Layer thickness/mm	Printing speed/mm*s ⁻¹	Infill density/%	Extrusion temperature/°C	Bed temperature/°C
(Hsueh et al., 2021)	0.2	35-45	20	180-220	25
(Algarni & Ghazali, 2021)	0.1	35	20	190-210	25
(Pandzic et al, 2019)	0.15	60	100	200	60
(Chalgham et al., 2021)	0.3	60	30	210	60
(Pastor- Artigues et al., 2019)	0.1	50	90	205	Not specified
(Hsueh et al., 2021)	0.2	35	10	204	60
(Rodríguez-Reyna et al., 2022)	0.14	35	33	210	50

Chapter 2

Materials and methods

The material of focus for this study is PLA. The initial filament is purchased from Ultimaker. The material is initially in its standard filament form. Using Ultimaker S3 3D printer the test specimens are made. The specimen printing parameters chosen are infill pattern, infill density, and extrusion temperature and other parameters that will remain constant for the whole process of the experiment shown in Table 2.1 remain constant throughout the experiment. To assess the effect of these parameters on the mechanical properties, different combinations of these parameters were set according to the Taguchi method. The algorithm of the experiment from previous studies [7] was adapted to this

Table 2.1: Printing parameters to be kept constant

Tab: 2

Parameter	Values
Layer thickness	0.3 mm
Bed temperature	25 °C
Build orientation	x-z plane
Nozzle diameter	0.25 mm
Printing speed	65 mm/s

case in Figure 2.1

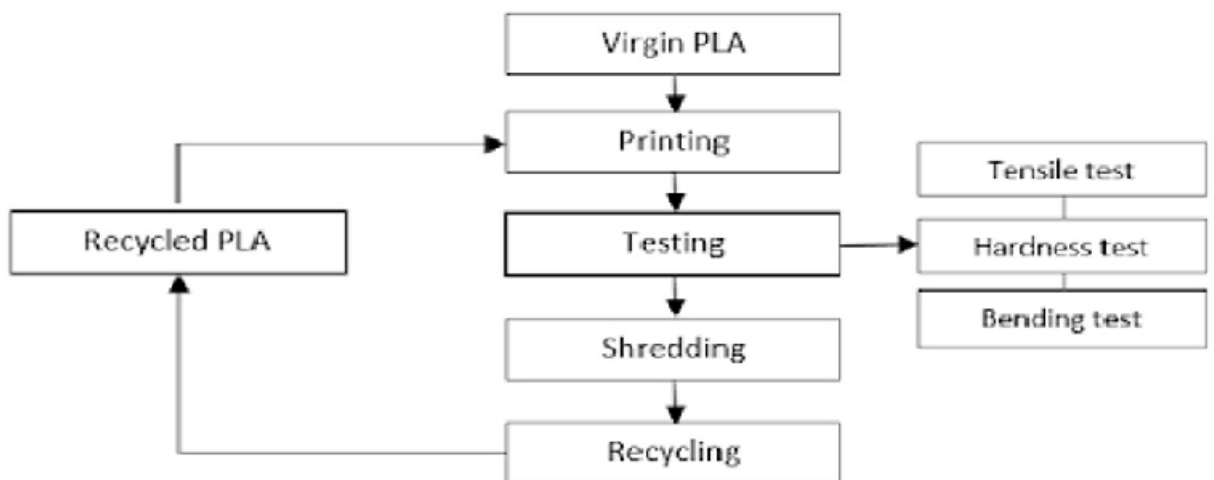

Figure 2.1: The adapted procedure of the experiment

fig:1

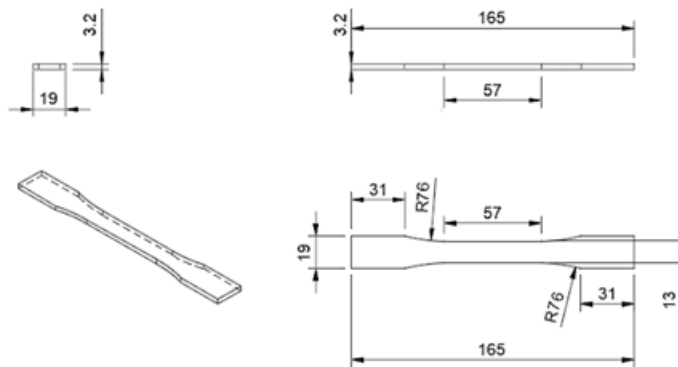

Figure 2.2: Tensile and bending specimen design

fig:2

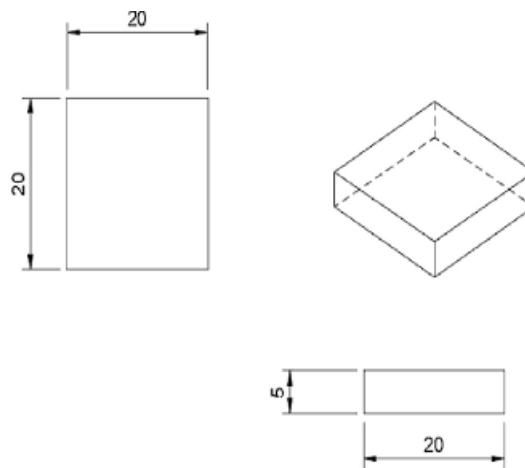

Figure 2.3: Hardness specimen design

fig:3

2.1 Specimen design

The tensile specimens should be prepared according to the ASTM standard D638-I (165.0 mm × 19.0 mm × 3.2 mm) [9]. and the similar specimen will be used for 3 point bending test. The specimen designs are shown below in Figure 2.2 The hardness test specimens are printed with the same parameters shown in the design table, with the dimensions of 20×20×5 mm depicted on Figure 2.3

2.2 Design of the experiment

To assess the effect of these parameters on the mechanical properties, different combinations of these parameters were set according to the Taguchi method, and are presented with the L9 orthogonal design table. This method is used to assess the effects of the parameters without having to perform full factorial analysis, which would have resulted in 27 specimens in a single set in this experiment. Using the Taguchi method allows us

to conserve time and the amount of material needed. The design of the experiment is described in the Table 2.2

Table 2.2: Design of the experiment

Tab: 4

	Infill pattern	Infill density/percent	Extrusion temperature/°C
1	Triangular	40	190
2	Triangular	60	200
3	Triangular	80	210
4	Tri-hexagonal	40	200
5	Tri-hexagonal	60	210
6	Tri-hexagonal	80	190
7	Octet	40	210
8	Octet	60	190
9	Octet	80	200

2.3 Experimental procedure

Three sets of specimens were printed to later be tested and the data points to be used for each mechanical property are the mean and standard deviation across the three sets for the corresponding specimen. The specimens were tested for tensile properties by putting them under deformation and elongating them in the tensile testing machine. The mechanical properties to be tested were the tensile properties such as yield strength, ultimate tensile strength, and Young modulus as well as hardness and visual properties. The Young modulus was calculated as the gradient of the stress-strain curve in the elastic region of the graph. The yield strength was determined using the 0.2 percent offset method, which is commonly used to define yield strength for metals but can be used for plastics as well, as in the [10]. The ultimate tensile strength was determined as the maximal stress value of the run. Also, from other experiments, Vickers hardness and bending strength of the material were found. The bending strength was measured as per the following Equation 2.1

$$\text{Bending strength} = \frac{3F * L}{2b * d^2} \quad (2.1) \quad \{\text{eq:1}\}$$

Where F is maximum load, L is a span taken as 57 cm, b and d are width and thickness. After the desired properties were measured, the specimens were shredded, melted, and reformed into new filaments. During the process the specimen will be broken down into smaller pieces so it will fit into the shredding machine. After shredding the pieces will go through the granulator to break them into smaller pieces, which can later be melted in the extrusion machine. The extrusion process will be repeated twice for one iteration of recycling. First stage of extrusion is palletization, where extruded filament goes into a palletizer which will shred the material to small pallets. For the second stage filament is extruded from melted pallets to make a complete spool. The new filament was used

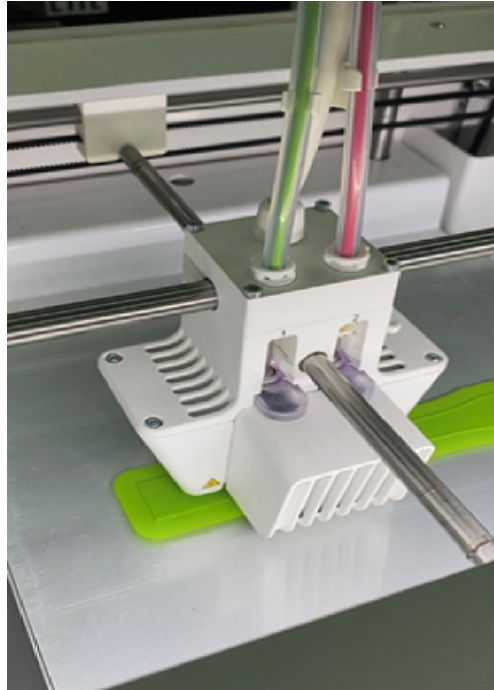

Figure 2.4: Printing process

fig:4

to print new specimens with the same parameters as shown in the design Table 2.2. The printing-testing-recycling cycle will be repeated few times, with the ultimate goal being the assessment of degradation of the material after repeated thermal processing and recycling. The process of printing, testing and recycling is depicted on Figures 2.4 to 3.8

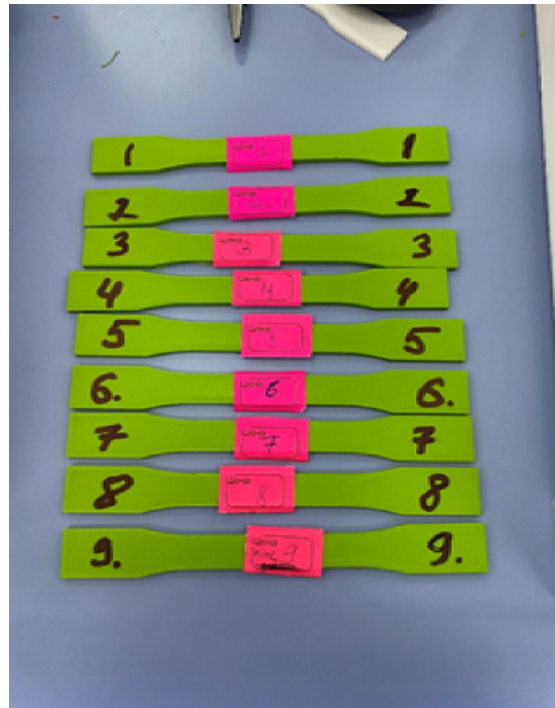

Figure 2.5: Printed specimen

fig:5



Figure 2.6: Tensile test

fig:6



Figure 2.7: Vickers hardness test

fig:7

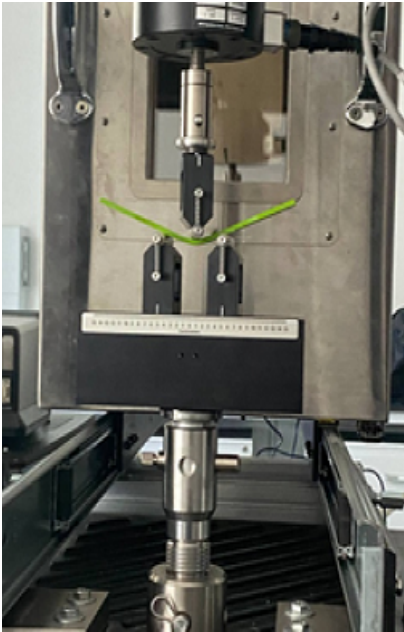

Figure 2.8: 3 point bending test

fig:8



Figure 2.9: Shredding machine

fig:9



Figure 2.10: Shredded and granulated PLA

fig:10



Figure 2.11: Material extrusion

fig:11



Figure 2.12: Palletized PLA

fig:12



Figure 2.13: Material goes into the extruder

fig:13



Figure 2.14: Diameter of the filament

fig:14



Figure 2.15: Spool made from filament.

fig:15

Chapter 3

Results and discussion

Overall, three sets of 9 samples were made for each experiment, resulting in a total of 27 printed specimens for tensile test, 27 for bending test and 27 for hardness test. For further discussion of the results the value of the signal-to-noise ratio was calculated, the value that is used in the Taguchi method to determine the effect of every parameter on the results of the experiment. The signal-to-noise ratio was determined using the Equation 3.1:

$$S/N = -10 * \log\left(\frac{1}{n} * \sum\left(\frac{1}{y^2}\right)\right) \quad (3.1) \quad \{\text{eq:2}\}$$

Where n is the total number of results observed and y is the observed results.

3.1 Tensile test

3.1.1 Tensile test of virgin material

In Table 3.1 the calculated values of Young modulus, yield strength, and ultimate tensile strength for virgin PLA are presented. The calculated values correspond to each level of the experiment described in the design of the experiment in Table ???. The coefficients of variation for every parameter were determined. The coefficient of variation can be described as the extent of variation from the mean value of the set and it can be calculated by using the Equation 3.2

$$k = \frac{SD}{xm} * 100 \quad (3.2) \quad \{\text{eq:3}\}$$

Where SD is the standard deviation and xm is the mean value. Therefore, the coefficients of variation for Young modulus, yield strength and ultimate tensile strength are 8.37, 7.79 and 8.99 percent correspondingly.

According to the results of the tests that can be seen in Table 3.1, it can be seen that the infill pattern and extrusion temperature have a great effect on the tensile properties of the material. In Figures 3.1, 3.2, 3.3 the difference in mean values for Young modulus, yield strength, and ultimate tensile strength concerning the printing parameter. The effect of the printing parameters on the tensile properties of the materials is shown in the 3.2. It can be seen, that the extrusion temperature and the infill density both have the greatest effect on the values of Young modulus, yield strength, and ultimate tensile strength and the delta values for these parameters are very close, while the effect of the infill pattern is lower than other parameters. According to Figures 3.1 to 3.3., the infill pattern of the material has a sensible effect on the tensile properties of the material, as the infill pattern directly involves

3. Results and discussion

	Infill pattern	Infill density/%	Extrusion temperature/°C	Young Modulus(average)/MPa	Yield strength(average)/MPa	Ultimate tensile strength(average)/MPa
1	Triangular	40	190	1856.1	23.02	27.1
2	Triangular	60	200	2141.1	24.12	30.5
3	Triangular	80	210	2255	26.4	34.3
4	Tri-hexagonal	40	200	1997.6	26.4	27.7
5	Tri-hexagonal	60	210	2251	27.9	31.9
6	Tri-hexagonal	80	190	2107.2	24.7	31.3
7	Octet	40	210	1875.7	24.7	29.3
8	Octet	60	190	2037	25.3	30.5
9	Octet	80	200	2204	29.7	35.5

Table 3.1: Results of the experiment

Tab:6

with internal geometry of the material. While specimens that have triangular patterns showed the lowest values for Young modulus, yield strength, and ultimate tensile strength, tri-hexagonal and octet shapes were noticed to improve the tensile characteristics of the material, as these structures allow denser supporting offsets. The values of yield strength and ultimate tensile strength increase with a change of the infill pattern from triangular to tri-hexagonal, however the mean yield strength and Young modulus for the octet decrease while the value of mean ultimate tensile strength for octet shape is greater than for the tri-hexagonal. It can be explained that material with tri-hexagonal shaped internal geometry stays longer on the region of the elastic deformation, while octet-shaped material requires a greater load for it to break under deformation. The extrusion temperature was shown

S/N Ration	Parameter level	Infill pattern	Extrusion temperature	Infill density
Young Modulus	1	66.35	65.62	66.01
	2	66.5	66.61	66.50
	3	66.17	66.80	66.52
	Delta	0.34	1.19	0.52
	Rank	3	1	2
Yield strength	1	27.77	27.84	27.72
	2	28.40	28.21	28.51
	3	28.46	28.58	28.40
	Delta	0.68	0.74	0.79
	Rank	3	2	1
Ultimate tensile strength	1	29.68	28.95	29.42
	2	29.61	29.82	29.85
	3	30.01	30.54	30.04
	Delta	0.40	1.59	0.62
	Rank	3	1	2

Table 3.2: Comparison of mean values of experiment results of tensile test

Tab:7

to have a great effect on the mechanical properties of the material as for Figures 3.1 to 3.3. The tensile properties showed to increase with the rise in temperature from 190°C to

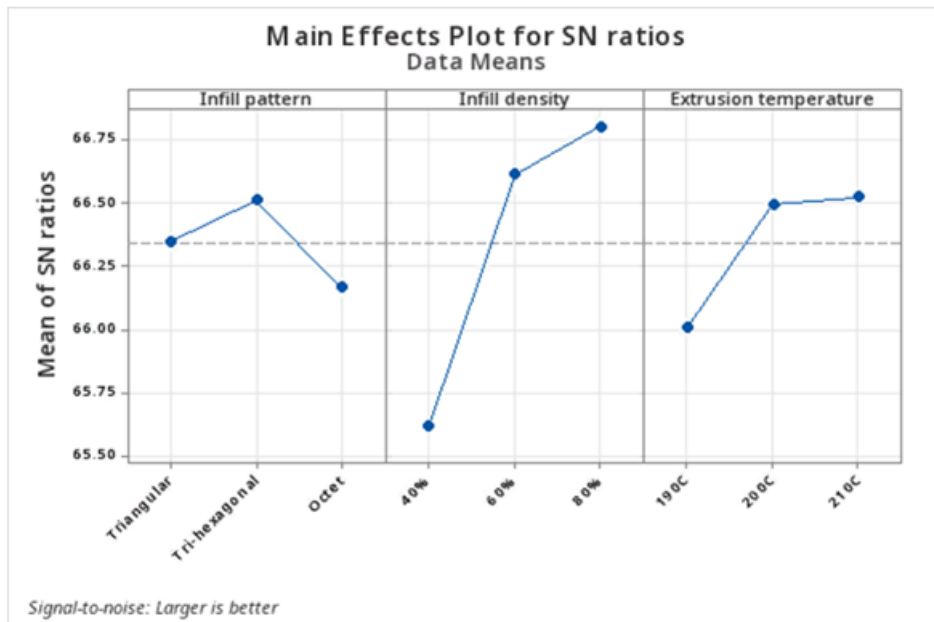

Figure 3.1: Effect of printing parameters on Young modulus

fig:7

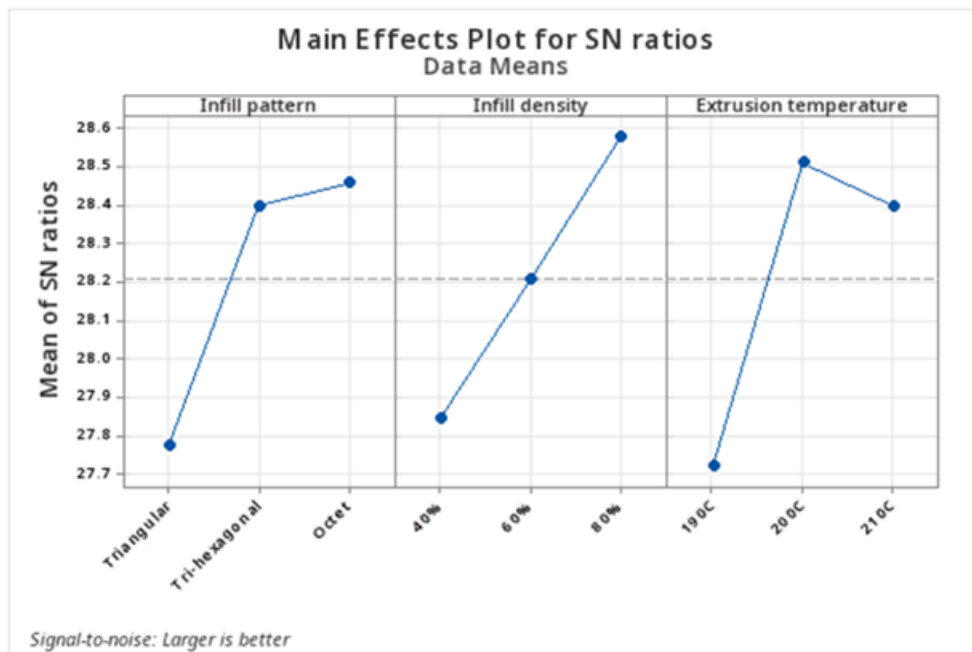

Figure 3.2: Effect of printing parameters on yield strength

fig:8

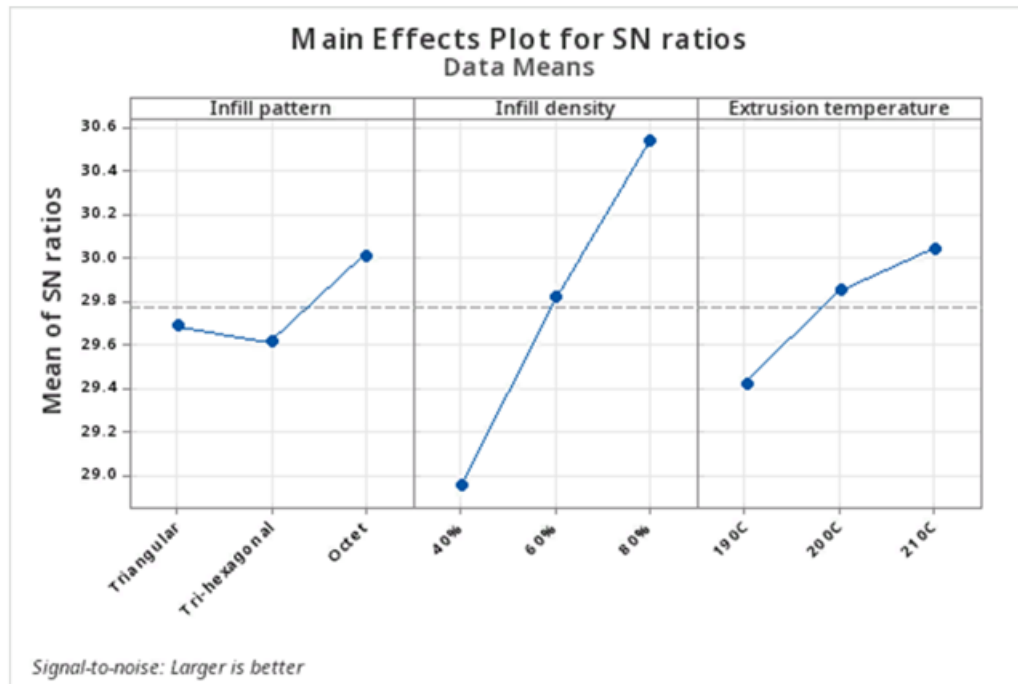

Figure 3.3: Effect of printing parameters on ultimate tensile strength

fig:9

200°C, however, while ultimate tensile strength rises further with an increase to 210°C, the yield strength is slightly decreased. Taking into account the fact that the number for the Young modulus grew only a little, it can be assumed that higher temperatures have a not pleasant effect on the elastic properties of the material, despite enhancing its ultimate tensile strength. Overall, the lowest printing temperature of 190°C resulted in the lowest values of Young modulus, yield strength, and ultimate tensile strength, while the optimal extrusion temperature is somewhere between 200°C and 210°C, as both of these parameters gave close values for tensile characteristics, however, 200°C is determined to be a better option. As it can be seen from Figures ?? to 3.3. and as it was expected from the literature review, the infill density has a direct effect on the tensile properties of the material. With the increase in infill density, the tensile characteristics improve as well, because with greater infill density the amount of material inside a specimen increases, hence the load-bearing capacity of a specimen improves, meaning that it longer remains in the elastic region when deformation occurs and it is harder to break it. As the trend of increase for Young modulus, yield strength, and ultimate tensile strength is almost directly proportional to an increase in infill density from 40 to 80 percent, the greater value of infill density – 80 percent, gives better tensile properties, however, 60 percent could also be the optimal value for the means of the economy of the material. The interaction plots were made to access the effect of combination of parameters on the mechanical properties of the PLA, Figures 3.4 to 3.6. From the interaction plots it can be seen that tri-hexagonal pattern gives the best result for the Young modulus out of three infill patterns, hence this parameter produces better elastic properties. However, for yield strength and ultimate

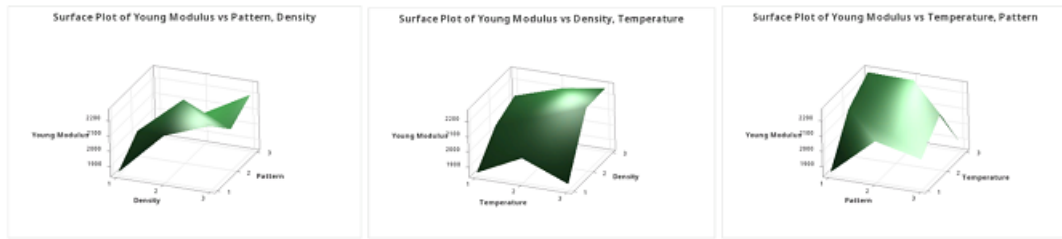

Figure 3.4: Interaction plots for Young modulus: From left to right - pattern vs density, density vs temperature, temperature vs pattern

fig:10

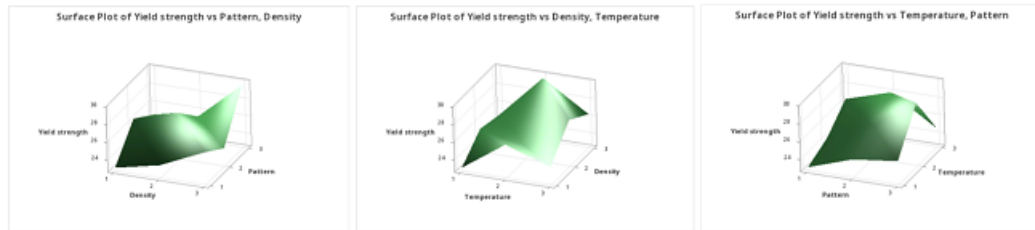

Figure 3.5: Interaction plots for yield strength: From left to right - pattern vs density, density vs temperature, temperature vs pattern

fig:11

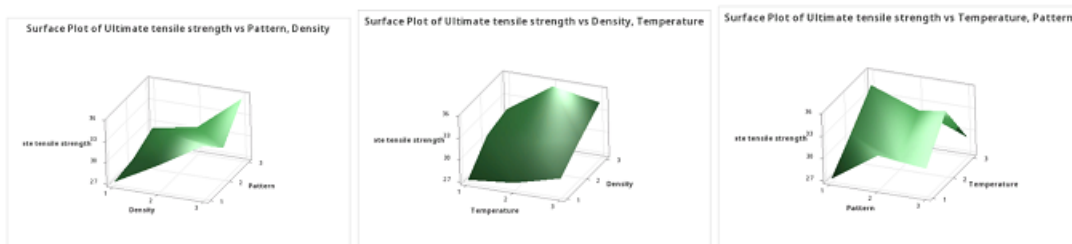

Figure 3.6: Interaction plots for ultimate tensile strength: From left to right - pattern vs density, density vs temperature, temperature vs pattern

fig:12

tensile strength octet pattern shows to have slightly better effect, which can be explained by effect of other parameters, though the tri-hexagonal shape gives good results for these characteristics as well, Also, the combination of the 80 percent infill density and 200°C results in the highest value for either Young modulus, yield strength and ultimate tensile strength.

3.1.2 Tensile test of recycled material

The recycled PLA shows different results in mechanical properties than the virgin material. Overall, as seen on Figures 3.7 to 3.12, the tensile properties of the material have decreased for each level, except for levels 4 and 5. One of the reasons for degradation of tensile properties of the PLA may be the effect of thermal processing of the material, as in the process of recycling and reprinting it was melted 3 times. Despite few positions having better results than the corresponding levels for non-recycled PLA, overall, the values of

3. Results and discussion

Young modulus, yield strength and ultimate tensile strength decreased. Moreover, the effect of the parameters has also changed. In comparison with virgin material, where octet pattern showed overall slightly better effect on mechanical properties than tr-hexagonal shape, for recycled PLA tr-hexagonal shape is results in far greater results for each of Young modulus, yield strength and ultimate tensile strength. Also, change of effect occurred with temperature as well, because after recycling highest temperature of 210°C gives better results, in comparison with not recycled PLA for which 200°C was the best temperature parameter. As for the infill density, after recycling the trend of highest density resulting the best characteristics remained, 80 percent is still better parameter, which can be explained that with higher density amount of material increases as well, and that improves the mechanical properties. The trend of degradation of tensile properties of the material remains after the second iteration of recycling as can be seen on the Table and Figures. From the same figures, even though for 4th and 5th level Young Modulus, yield strength and ultimate tensile strength are slightly higher than for virgin PLA, the results after second recycling are lower even for these levels. The comparison of results of tensile test as values of Young modulus, yield strength and ultimate tensile strength for virgin PLA and after each iteration of recycling are depicted on Figures 3.13 to 3.18 and Tables 3.3 to 3.6

S/N Ration	Parameter level	Infill pattern	Extrusion temperature	Infill density
Young Modulus	1	64.45	64.92	64.69
	2	67.13	65.22	64.89
	3	64.86	65.92	66.67
	Delta	2.68	1.00	1.98
	Rank	1	3	2
Yield strength	1	25.97	26.45	26.39
	2	28.98	26.52	26.45
	3	26.19	27.68	27.89
	Delta	3.01	1.23	1.47
	Rank	3	1	2
Ultimate tensile strength	1	27.19	27.75	27.67
	2	29.94	27.98	27.54
	3	27.76	28.77	29.47
	Delta	2.75	1.02	1.93
	Rank	1	3	2

Table 3.3: Comparison of mean values of experiment results of tensile test for recycled PLA

Tab:8

3.2 Vickers hardness test

3.2.1 Vickers hardness test of virgin material

The Vickers hardness test was performed with 200 g load at room temperature, according to ASTM D256 standard. To make comparisons of the results, the S-N curves regarding

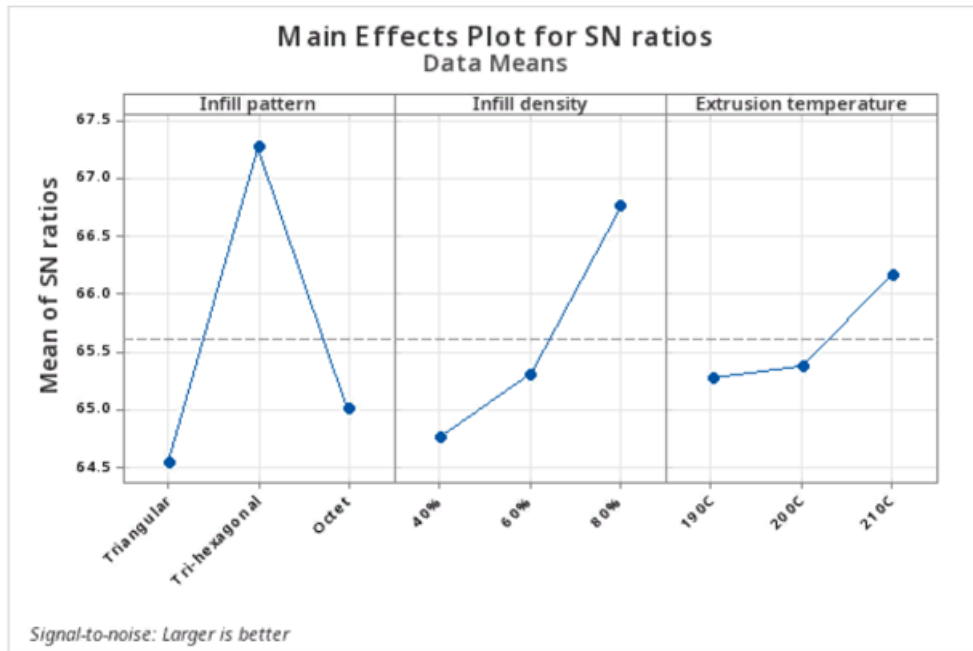

Figure 3.7: Effect of printing parameters on Young modulus for recycled PLA

fig:13

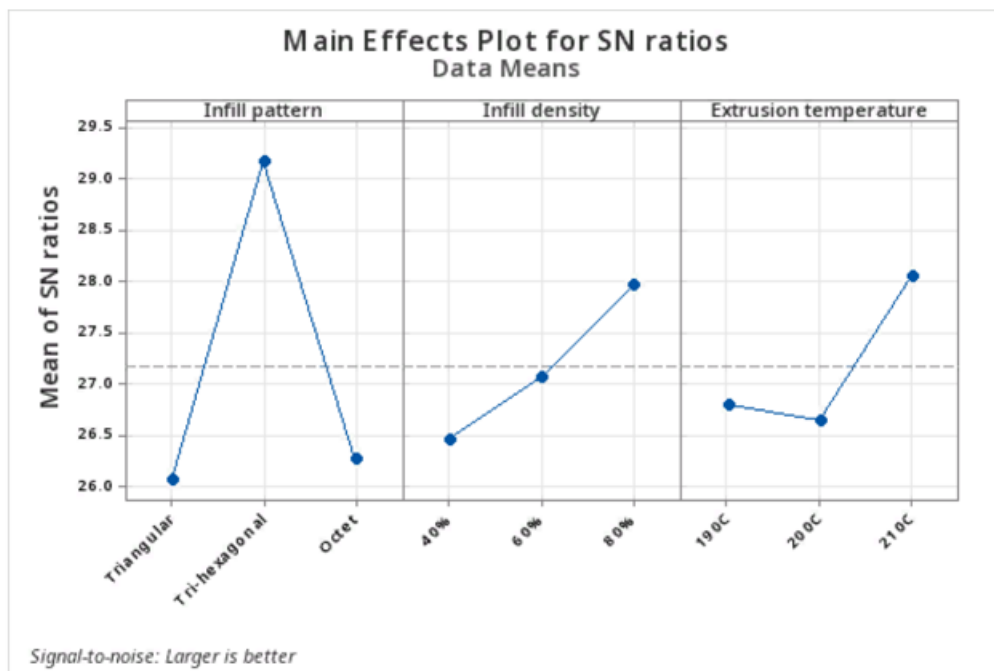

Figure 3.8: Effect of printing parameters on yield strength for recycled PLA

fig:14

3. Results and discussion

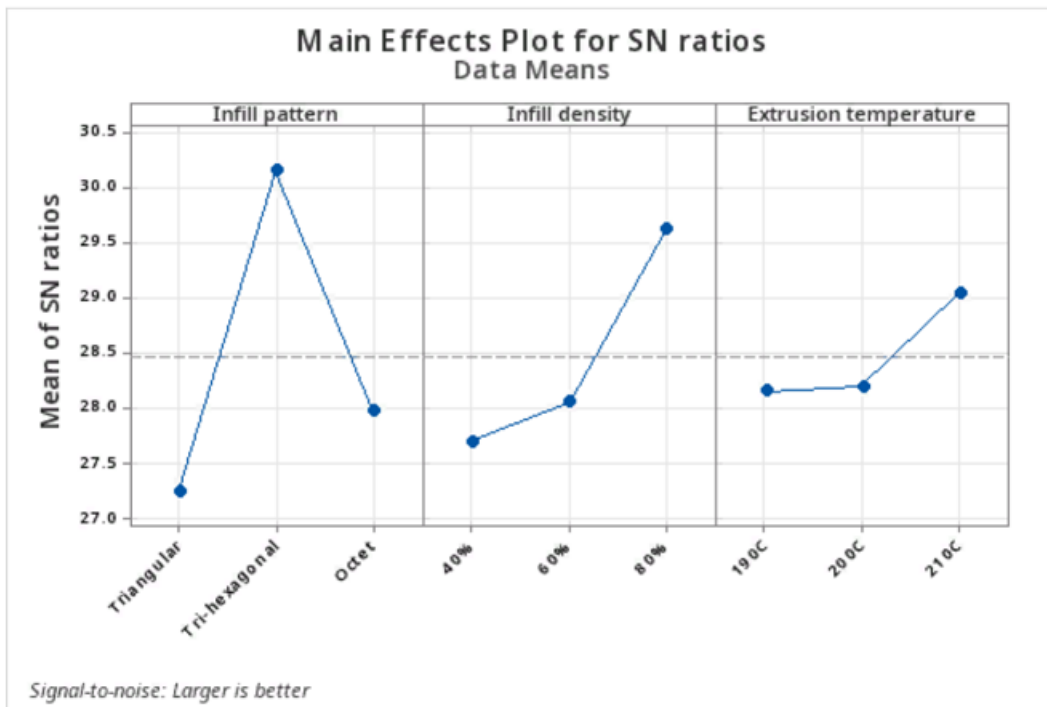

Figure 3.9: Effect of printing parameters on ultimate tensile strength for recycled PLA

fig:15

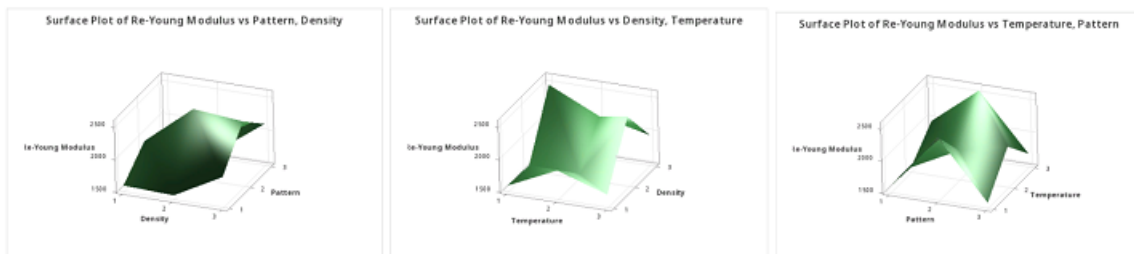

Figure 3.10: Interaction plots for Young modulus for recycled PLA: From left to right - pattern vs density, density vs temperature, temperature vs pattern

fig:16

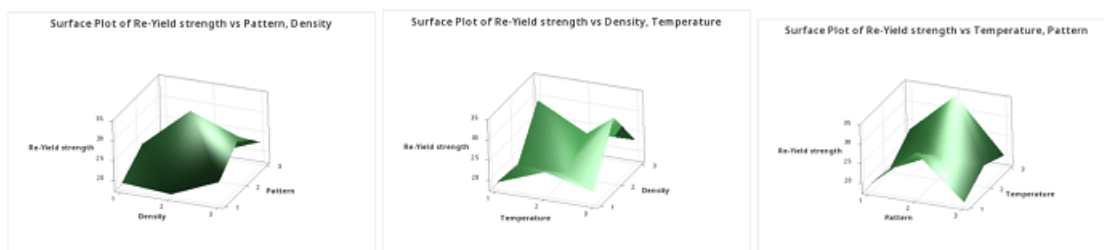

Figure 3.11: Interaction plots for yield strength for recycled PLA: From left to right - pattern vs density, density vs temperature, temperature vs pattern

fig:17

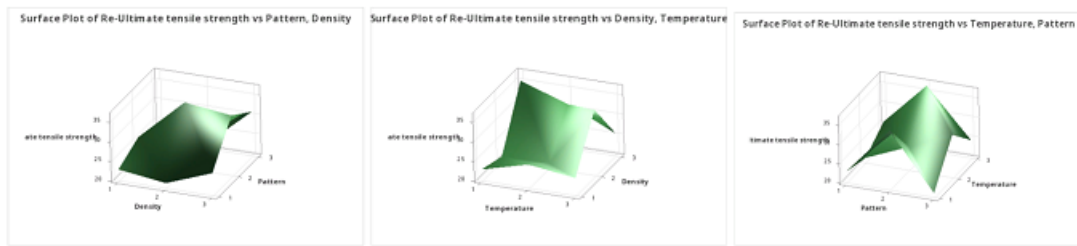

Figure 3.12: Interaction plots for ultimate tensile strength for recycled PLA: From left to right - pattern vs density, density vs temperature, temperature vs pattern

fig:18

#	Young Modulus/MPa	Re- Young Modulus/MPa	Re- Young Modulus/MPa
1	1856±59	1580±62	1590±76
2	2141±32	1553±81	1685±65
3	2255±72	1954±5	1937±89
4	1997±22	1940±25	1961±16
5	2251±42	2557±13	2522±40
6	2107±34	2485±17	2464±51
7	1875±30	1683±58	1680±66
8	2037±32	1572±74	1612±16
9	2204±14	2125±33	2064±50

Table 3.4: Young modulus values for virgin, recycled and re-recycled PLA

Tab:9

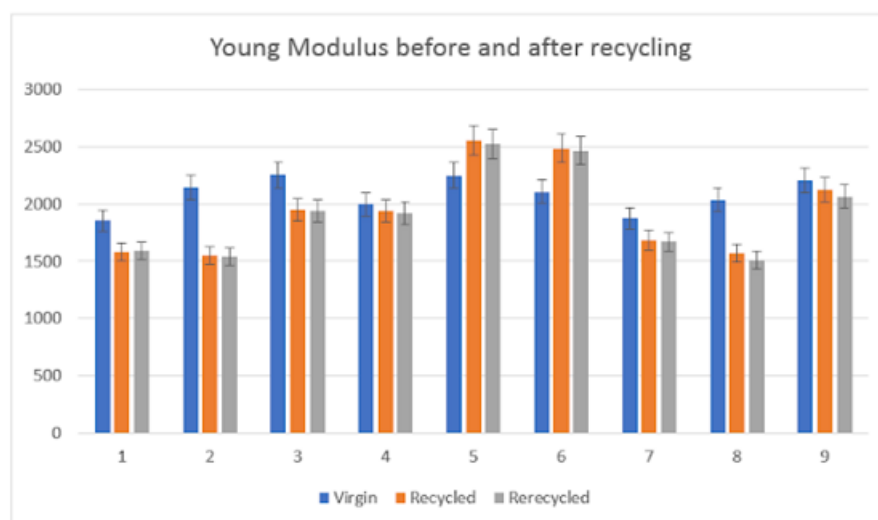

Figure 3.13: Comparison of Young modulus values for virgin, recycled and re-recycled PLA

fig:19

3. Results and discussion

#	Yield strength/MPa	Re-Yield strength/MPa	Re-Yield strength/MPa
1	23.0±0.16	19.2±0.66	18.9±0.15
2	24.1±0.74	18.2±0.85	17.3±0.24
3	26.4±0.21	23.2±0.29	22.1±.011
4	26.4±0.33	23.7±0.34	23.2±0.12
5	27.9±0.15	34.1±0.24	27.1±0.64
6	24.7±0.23	29.4±0.21	24.5±0.22
7	24.7±0.98	20.4±0.91	19.1±0.92
8	25.3±0.16	18.5±0.98	18.5±0.49
9	29.7±0.12	23.0±0.96	22.5±0.86

Table 3.5: Yield strength values for virgin, recycled and re-recycled PLA

Tab:10

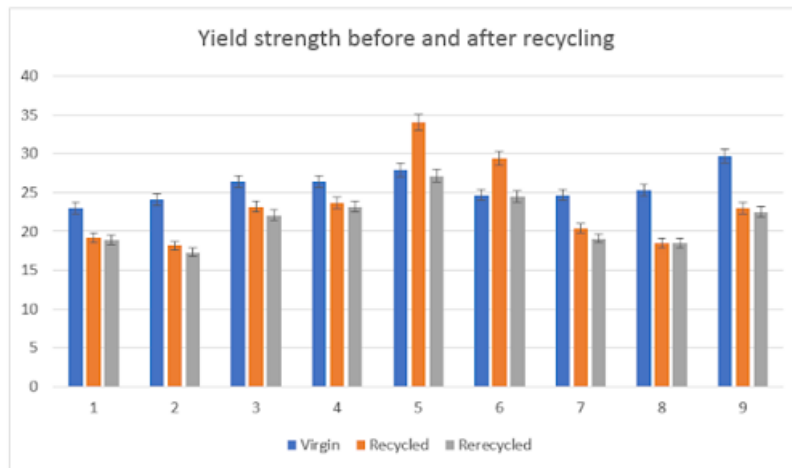

Figure 3.14: Comparison of yield strength values for virgin, recycled and re-recycled PLA

fig:20

#	Ultimate tensile strength/MPa	Re-Ultimate tensile strength/MPa	Re-Ultimate tensile strength/MPa
1	27.1±0.62	22.7±0.25	21.7±0.11
2	30.5±0.27	21.1±0.18	20.6±0.58
3	34.3±0.49	25.5±0.49	25.3±0.79
4	27.7±0.46	25.9±0.73	24.9±0.17
5	31.9±0.40	36.6±0.04	31.1±0.12
6	31.3±0.02	35.2±0.23	28.9±0.15
7	29.3±0.85	24.3±0.18	24.2±0.29
8	30.5±0.24	20.9±0.77	20.7±0.24
9	35.5±0.46	31.0±0.65	27.7±0.14

Table 3.6: Ultimate tensile strength values for virgin, recycled and re-recycled PLA

Tab:11

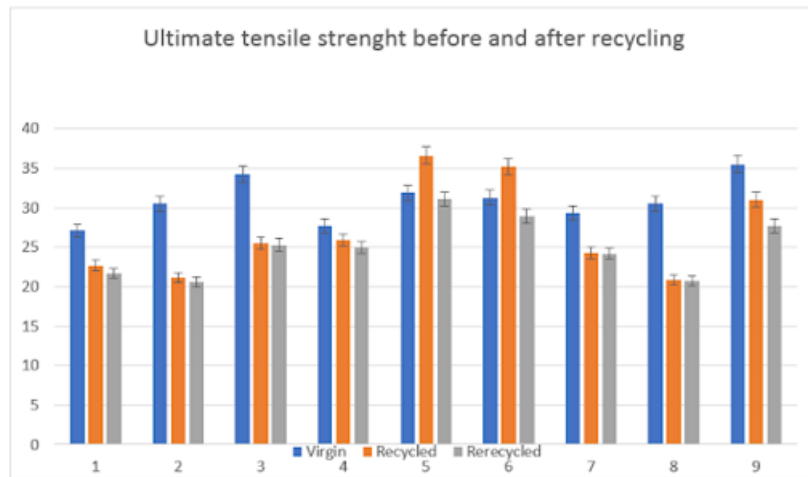

Figure 3.15: Comparison of ultimate tensile strength values for virgin, recycled and re-recycled PLA

fig:21

different temperatures in 3 categories of infill density and infill patterns were provided in Figure 3.16 As a preliminary analysis, at the first printing stage the octet, 80 percent infill density, 190 degrees had the highest signal to noise ratios, which show low scattering of data points and high signal quality. While, at the second printing stage tri-hexagonal, 60 percent infill density, 210°C of extrusion temperature replaces the previous points. It could be attributed to thermal reinforcement and extrusion processes the PLA was exposed to, which determines its quality and optimal conditions. The data accuracy and reliability of hardness tests can be concluded from them. The obtained results as well as scatter-band diagrams from 3 printing stages are comparable. Fig . Surface plot of hardness tests of original PLA and firstly and secondly recycled PLA. The contour plot shown in Figure 3.17 shows the relationship between Temperature, Infill pattern and density values and hardness values assigned for each PLA sample. Maintaining the medium infill density(60 percent) during the printing results in poorly hard printing samples. However, maintaining high infill density(80 percent) combined with octet pattern might significantly affect positively the hardness value of the PLA. Shortly, the best optimal parameters for high hardness values are: 190°C of extrusion temperature, 80 percent infill density, 190°C of extrusion temperature, octet pattern.

3.2.2 Vickers hardness test of recycled material

On the contrary, these trends might undergo changes with recycling. The peak on the re-hardness plot corresponds with the highest hardness values, and is observed precisely at $T = 200^{\circ}\text{C}$ and Infill density = 60 percent; at tri-hexagonal pattern and $T = 200^{\circ}\text{C}$. It is established that heating the printing apparatus would increase the likelihood of obtaining the hardest material. According to the results of the third recycling, the octet pattern combined with 200°C extrusion temperature gives the highest hardness value. It is

3. Results and discussion

S/N Ration	Parameter level	Infill pattern	Extrusion temperature	Infill density
Vickers hardness of virgin PLA	1	24.64	25.05	25.47
	2	25.30	24.81	25.14
	3	25.57	25.64	24.90
	Delta	0.92	0.83	0.57
	Rank	1	2	3
Vickers hardness of recycled PLA	1	25.18	24.99	25.51
	2	26.03	25.76	25.14
	3	25.23	25.69	25.79
	Delta	0.85	0.77	0.65
	Rank	1	2	3

Table 3.7: Comparison of mean values of experiment results of Vickers hardness test

Tab:12

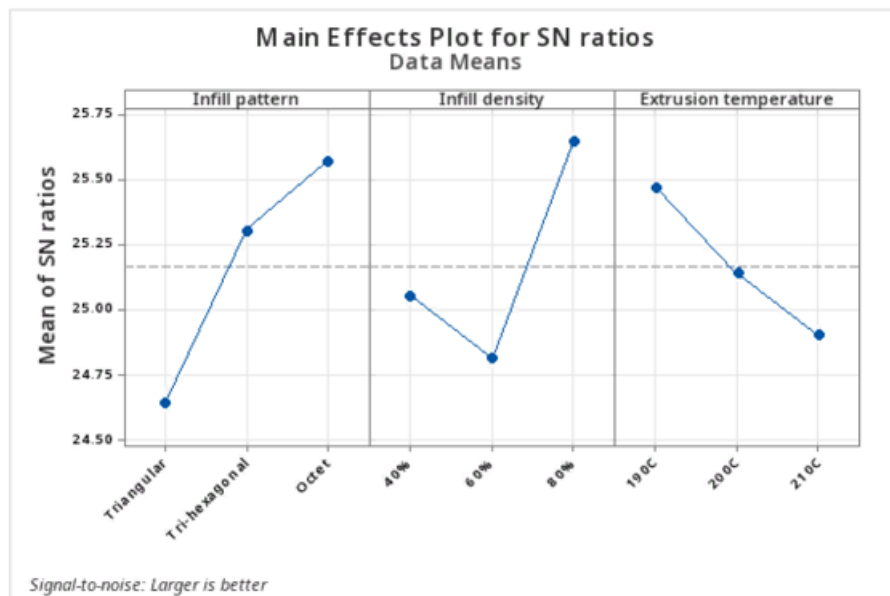

Figure 3.16: Effect of printing parameters on Vickers hardness

fig:22

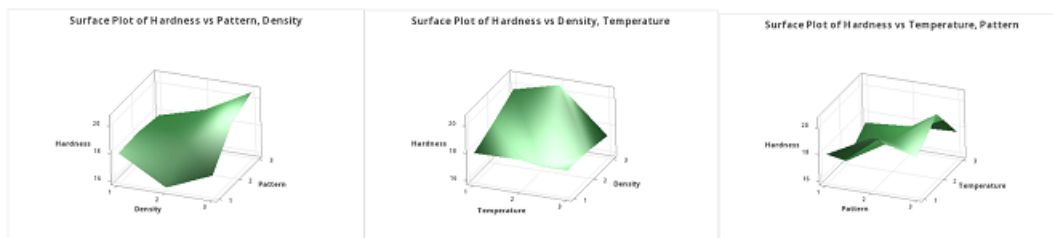

Figure 3.17: Interaction plots for Vickers hardness: From left to right - pattern vs density, density vs temperature, temperature vs pattern

fig:23

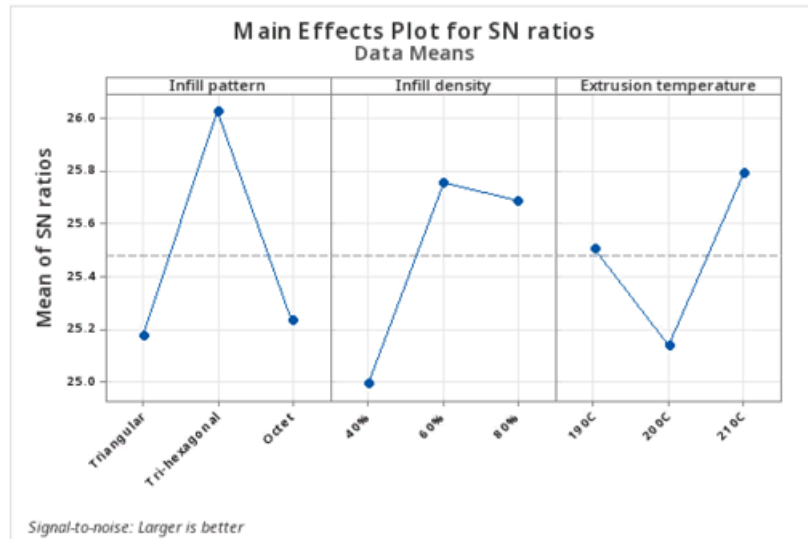

Figure 3.18: Effect of printing parameters on Vickers hardness for recycled PLA

fig:24

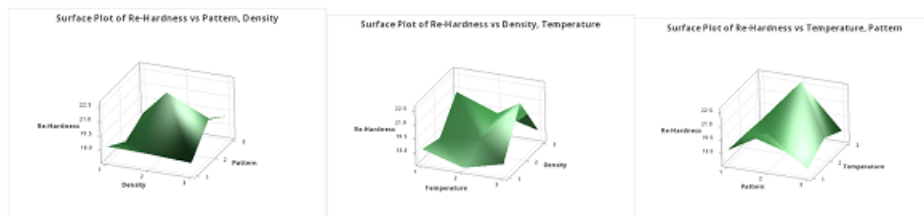

Figure 3.19: Interaction plots for Vickers hardness for recycled PLA: From left to right - pattern vs density, density vs temperature, temperature vs pattern

fig:25

established that heating the printing apparatus would increase the likelihood of obtaining the hardest material. The interaction plots shown in Figure 33 a,c, e shows the relationship between Temperature, Infill pattern and density values and hardness values assigned for each PLA sample. Maintaining the medium infill density(60 percent) during the printing results in poorly hard printing samples. However, maintaining high infill density(80 percent) combined with octet pattern might significantly affect positively the hardness value of the PLA. Shortly, the best optimal parameters for high hardness values are: 190 °C of extrusion temperature, 80 percent infill density, 190°C of extrusion temperature, octet pattern. On the contrary, these trends might undergo changes with recycling. The peak on the re-hardness plot corresponds with the tri-hexagonal pattern and 210°C temperature.

3.3 3 point bending test

3.3.1 3 point bending test of virgin material

During the 3 point bending test the load was applied vertically on the specimen until it breaks. According to Figure 3.21 the infill pattern and extrusion temperature has the

3. Results and discussion

#	Hardness/HV	Re-Hardness/HV	Re-Re-Hardness/HV
1	17.93±0.88	18.31±0.82	18.21±0.17
2	15.96±1.27	18.19±0.59	19.44±0.19
3	17.36±1.91	17.94±0.24	19.41±0.59
4	17.98±0.72	16.95±0.26	17.02±0.22
5	17.62±1.47	22.79±0.85	19.49±0.89
6	19.69±1.18	20.77±1.68	21.77±0.22
7	17.76±0.86	18.07±0.56	21.62±0.61
8	18.73±0.17	17.62±0.89	21.94±0.17
9	20.55±0.17	19.14±0.15	19.06±0.54

Table 3.8: Vickers hardness values for virgin, recycled and re-recycled PLA

Tab:14

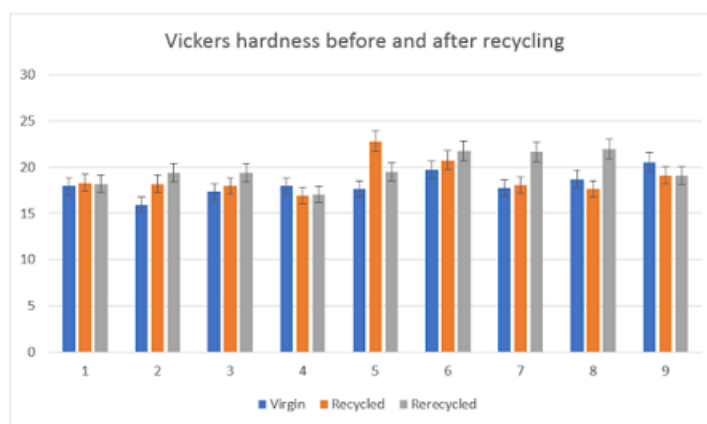

Figure 3.20: Comparison of Vickers hardness values for virgin, recycled and re-recycled PLA

fig:26

least effect on the bending strength of the material, as the infill density gives great effect due to the increase of mass of material with the same size. The effect of infill pattern and extrusion temperature is very close. Out of three infill patterns tri-hexagonal pattern results in greater value of bending strength, while octet gives the lowest value, which can be explained by the fact that tri-hexagonal pattern is the most stable and can give more material with same density as other patterns. The bending strength of the material increases with increase in infill density, as well as with increase in extrusion temperature. Interaction plots were made to monitor the effect of combination of parameters on material properties. In the result, the combination of greatest density and tri-hexagonal shape gives the best result, and also greatest density with 210°C temperature results in the biggest bending strength.

3.3.2 3 point bending test of recycled material

After the recycling, the effect of extrusion temperature has become the greatest out of three parameters, which can be explained that after thermal treatment structural integrity

S/N Ration	Parameter level	Infill pattern	Extrusion temperature	Infill density
Bending strength of virgin PLA	1	36.39	36.05	35.91
	2	36.18	36.28	36.13
	3	36.10	36.34	36.63
	Delta	0.29	0.29	0.73
	Rank	2	3	1
Bending strength of recycled PLA	1	34.02	33.52	35.06
	2	34.78	35.01	33.97
	3	34.77	35.04	34.54
	Delta	0.76	1.52	1.09
	Rank	3	1	2

Table 3.9: Comparison of mean values of experiment results of 3 point bending test

Tab:15

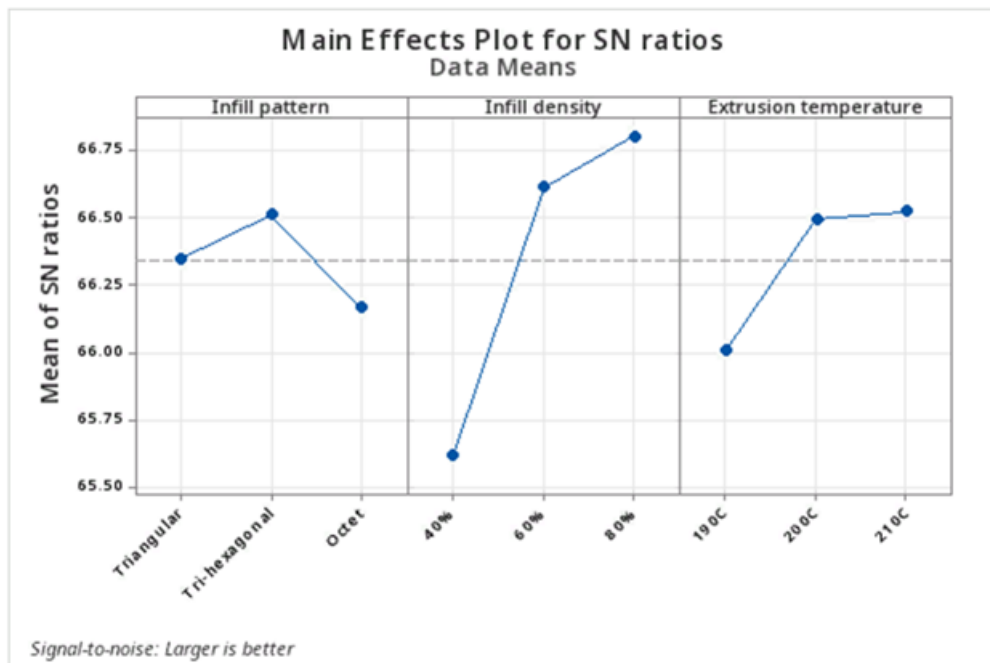

Figure 3.21: Effect of printing parameters on bending strength

fig:27

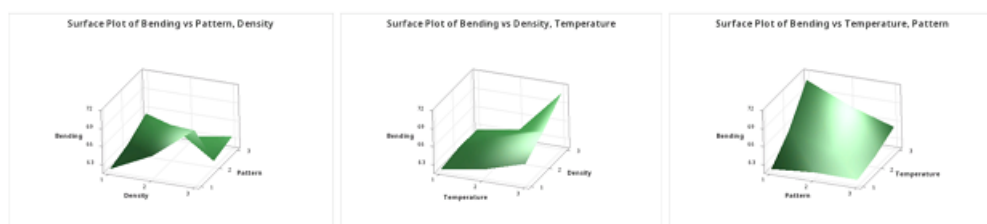

Figure 3.22: Interaction plots for bending strength: From left to right - pattern vs density, density vs temperature, temperature vs pattern

fig:28

3. Results and discussion

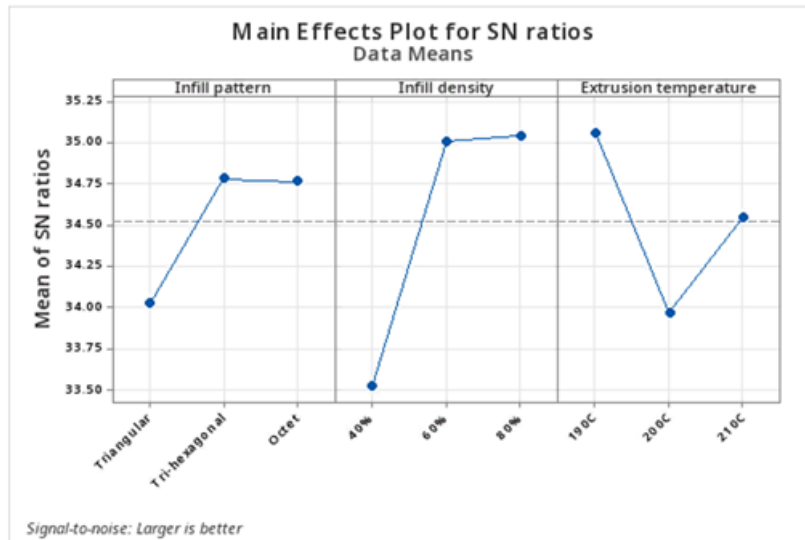

Figure 3.23: Effect of printing parameters on bending strength for recycled PLA

fig:29

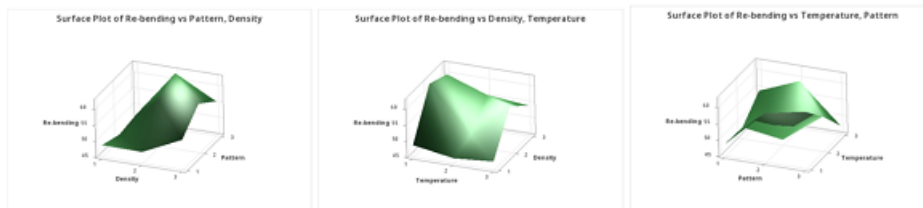

Figure 3.24: Interaction plots for bending strength for recycled PLA: From left to right - pattern vs density, density vs temperature, temperature vs pattern

fig:30

of the material decreased and the amount of material does not have the same great effect on its properties. As for extrusion temperature, if 200°C and 210°C gave really close great results for bending strength before recycling, after 200°C temperature has the least effect on the material, while 190°C gives the best value of bending strength, which can be explained that after recycling higher temperatures degrade the material properties more. All in all, as can be seen on Table 3.10 and Figure 3.25, the bending strength has decreased for all levels and that trend remained after the second iteration of recycling, resulting in reduction of bending strength to about 50 percent.

#	Bending strength/MPa	Re-Bending strength/MPa	Re-Re-Bending strength/MPa
1	62.05±0.53	48.50±0.65	21.43±0.51
2	65.43±0.55	48.31±0.35	30.64±0.21
3	70.84±0.22	54.15±0.72	32.09±0.39
4	63.15±0.59	46.41±0.47	33.05±0.43
5	67.59±0.77	59.18±0.63	35.32±0.23
6	62.62±0.37	60.02±0.44	32.48±0.59
7	65.26±0.22	47.37±0.56	30.99±0.16
8	62.59±0.54	62.38±0.43	35.22±0.59
9	63.63±0.42	55.52±0.72	35.59±0.09

Table 3.10: Bending strength values for virgin, recycled and re-recycled PLA

Tab:16

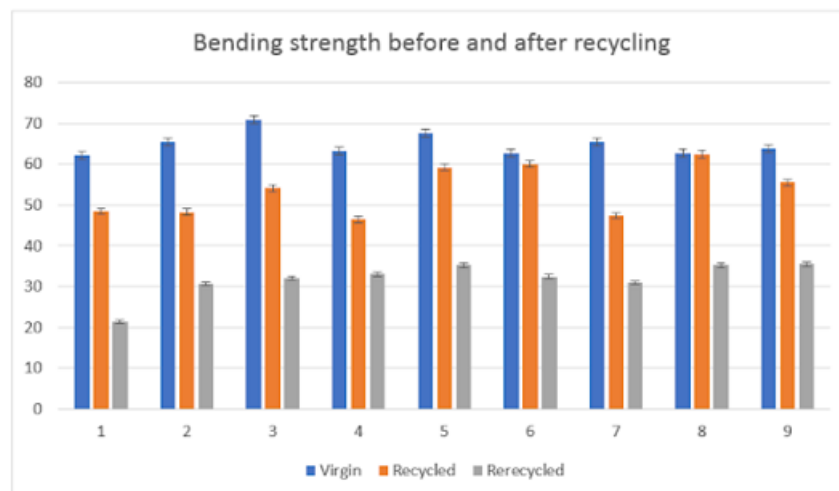

Figure 3.25: Comparison of Vickers hardness values for virgin, recycled and re-recycled PLA

fig:31

Chapter 4

Conclusion

This study focuses on the optimization of the FDM printing process by investigating the mechanical properties of the material, which is PLA in this case, and on the printability of the recycled material. At this stage of the study, the characteristics of the material were studied, by comparing the change in tensile properties when using different printing parameters. According to the results, the infill density and extrusion temperature are linearly correlated with the tensile properties of the material with the increase in values of Young modulus, yield strength, ultimate tensile strength and bending strength with an increase in infill density and printing temperature. Infill patterns also affected the material and showed that a tri-hexagonal shape pattern is the optimal parameter to keep the mechanical characteristics of the material in every recycling. Overall, according to the investigation, parameters of 80 percent infill density, 200°C extrusion temperature, and tri-hexagonal shape pattern of the material are optimal for tensile, hardness and bending properties of the material. The recycling is not so effective for flexural properties of the PLA, however with right printing parameters such as tri-hexagonal shape, 80 percent infill density and 190°C extrusion temperature, the results can be really close to the bending strength of virgin material, even though repetition of the recycling process will significantly decrease flexural strength.

Bibliography

- [1] M. Algarni and S. Ghazali, “Comparative Study of the Sensitivity of PLA, ABS, PEEK, and PETG’s Mechanical Properties to FDM Printing Process Parameters,” 2021.
- [2] A. Chalgham, A. Ehrmann, and I. Wickenkamp, “Mechanical Properties of FDM Printed PLA Parts before and after Thermal Treatment.,” 2021.
- [3] M. Atakök, G. and Kam and H. B. Koc, “ Tensile, three-point bending and impact strength of 3D printed parts using PLA and recycled PLA filaments: A statistical investigation,” 2022.
- [4] M. Gilbert, “Plastics materials: Introduction and historical development.,” 2017.
- [5] M. B. T. . A. J. M. MacLeod, H. P. Arp, “The global threat from plastic pollution,” 2020.
- [6] . W. E. Shen, L., “ Plastic recycling,” 2024.
- [7] P. Zhao, C. Rao, F. Gu, N. Sharmin, and J. Fu, “Close-looped recycling of polylactic acid used in 3D printing: An experimental investigation and life cycle assessment ,” 2018.
- [8] M. H. Hsueh, C. J. Lai, C. F. Chung, S. Wang, W. C. Huang, C. Y. Pan, Y. Zeng, and C. H. Hsieh, “ Effect of Printing Parameters on the Tensile Properties of 3D-Printed Polylactic Acid (PLA) Based on Fused Deposition Modeling. Polymers,” 2021.
- [9] M. Hikmat, S. Rostam, and Y. M. Ahmed, “Investigation of tensile property-based Taguchi method of PLA parts fabricated by FDM 3D printing technology. ,” 2021.
- [10] R. M, S. C. Hidajat, R. P. I, G, H. B, M. M, and T. F, “Infill pattern and density effects on the tensile properties of 3D printed PLA material,” 2019.