

Numerical Simulation of Low Salinity Water Alternating CO₂ Injection in Sandstone Reservoirs: A Hybrid EOR Approach

By

Zhambyl Sarbas

2020

A thesis submitted to the School of Mining and Geosciences of Nazarbayev
University in Partial Fulfillment of the Requirements for the Degree of
Master of Science in Petroleum Engineering

Nazarbayev University
2020

ACKNOWLEDGEMENTS

First and foremost, I would like to express gratitude and sincere appreciation to my thesis supervisor, Dr. Ali Shafiei, who has provided continuous support and guidance during my time pursuing a master's degree in Nazarbayev University. My special thanks go to my co-supervisor, Dr. Jalal Foroozesh from Universiti Teknologi PETRONAS in Malaysia, for his valuable comments and advice that led to the right navigation while conducting this research work.

I am also very thankful to my thesis committee members Dr. Peyman Pourafshary and Dr. Lei Wang for reviewing my thesis and for their constructive comments with improved the clarity and quality of the writing. I also would like to express my appreciation to the rest of the administrative and academic staff of the petroleum engineering department especially Dr. Muhammad Hashmet, Prof. Randy Hazlett, and Dr. Sonny Irawan.

This work was part of the Faculty Development Competitive Research Grants Program (FDCRGP) grant entitled: "LSWF: Experimental and Modeling Investigation of Low Salinity Water Flooding in some Oil fields of Republic of Kazakhstan – Improved Oil Recovery Implications." I wish to acknowledge the financial support I received from this grant.

I wish to say that I was pleased to have my roommates Medet Yerkin and Askhat Abdrakhmanov as research teammates. We had a good time over this time, and that is utterly true. Also, I dedicate special thanks to Marzhan Karimova, my life long groupmate, for her assistance and support during the process of learning CMG. Of course I cannot but mention rest of SQUAD team that includes Zhandos Askar, Damir Karimov, and Nurzhan Seitmaganmetov. I enjoyed our time together!

I am unboundedly grateful to my Sauveur for being by my side this time and forever.

Lastly, I dedicate my dissertation to my parents Bolatkhan and Elza for their unfailing love.

ORIGINALITY STATEMENT

I, Zhambyl Sarbas, hereby declare that this submission is my own work and to the best of my knowledge it contains no materials previously published or written by another person, or substantial proportions of material which have been accepted for the award of any other degree or diploma at Nazarbayev University or any other educational institution, except where due acknowledgement is made in the thesis.

Any contribution made to the research by others, with whom I have worked at NU or elsewhere is explicitly acknowledged in the thesis.

I also declare that the intellectual content of this thesis is the product of my own work, except to the extent that assistance from others in the project's design and conception or in style, presentation and linguistic expression is acknowledged.

Signed on 15.04.2020

NOMENCLATURE

Acronyms and Abbreviations

1D	=	One Dimensional
2D	=	Two Dimensional
3D	=	Three Dimensional
AN	=	Acidic Number
CMG	=	Computer Modeling Group
COBR	=	Crude Oil Brine Rock
DFM	=	Discrete Fracture Matrix
dFW0.01	=	100 Times Diluted Formation Water
dFW0.1	=	10 Times Diluted Formation Water
DVLO	=	Derjaguin-Landau-Verwey-Overbeek
EOR	=	Enhanced Oil Recovery
FCM	=	First-contact Miscible
GEM	=	General Equation of State Model
HSWAG	=	High Salinity Water Alternating Gas
ID	=	Identification
IFT	=	Interfacial Tension
IOR	=	Improved Oil Recovery
LFWF	=	Low Salinity Waterflooding
LS	=	Low Salinity
LSWAG	=	Low Salinity Water Alternating Gas
MCM	=	Multiple-contact Miscible
MME	=	Minimum Miscibility Enrichment
MMP	=	Minimum Miscibility Pressure
OOIP	=	Original Oil In Place

PHREEQC (program)	=	abbreviated from PH (pH), RE (redox), EQ (equilibrium), and C
PV	=	Pore Volume
RF	=	Recovery Factor
SCR	=	Surface Complexation Reactions
STOIIIP	=	Stock Tank Oil Initially In Place
SW	=	Seawater
SWAG	=	Simultaneous Water and Gas
SWCTT	=	Single-well Chemical Tracer Tests
UTCHEM	=	University of Texas Chemical Simulator
UTCOMP	=	University of Texas Compositional Simulator
WAG	=	Water Alternating Gas
WRAC	=	Workplace Risk Assessment & Control
XRD	=	X-ray Diffraction

Symbols

\hat{A}_β	=	reactive surface area of mineral β , (m^2)
A_k	=	chemical symbol for the k-th aqueous component, (dimensionless)
$K_{eq,\beta}$	=	chemical equilibrium constant for mineral reaction β , (dimensionless)
Q_β	=	the activity product of mineral reaction β , (dimensionless)
R_{aq}	=	number of reactions between aqueous species, (dimensionless)
k_r	=	relative permeability, (dimensionless)
k_β	=	rate constant for mineral β , (M/hr)
n_k	=	number of kinetic reactions, (dimensionless)
n_p	=	number of fluid phases, (dimensionless)
n_q	=	number of equilibrium reactions, (dimensionless)
r_k	=	rate of kinetic reaction, (mol/L/hr)

r_q	=	rate of equilibrium reaction, (mol/L/hour)
r_β	=	rate for mineral β , (mol/L/hour)
C	=	stoichiometric coefficient, (moles of basic species)
D	=	dispersion tensor, (m ² /s)
P	=	pressure, (Pa)
S	=	saturation (% or fraction)
T	=	temperature, (°C)
T	=	time, (day)
X	=	molar fraction (fraction)
Z	=	depth, (m)
A	=	cross-sectional area, (m ²)
f	=	fugacity, (Pa)
k	=	absolute permeability, (mD)
p	=	phase, (dimensionless)
q	=	flow rate, (m ³ /day)
u	=	superficial velocity, (m/s)
x	=	distance in the x direction, (m)

Greek Letters

β_c	=	unit conversion factor for the transmissibility coefficient, (0.0864 for SPE Preferred SI units)
Z	=	selectivity coefficient, (dimensionless)
Φ	=	fluid potential, (J/kg)
γ	=	fluid gravity, (SG)
γ	=	activity coefficient, (dimensionless)
μ	=	fluid viscosity, (cP)
ρ	=	density, (kg/m ³)

ϕ = porosity (% or fraction)

Metric Conversion Factors

1 Darcy = 9.869 E-13 m²

1 cP = 0.001 Pa.s

1 ppm = 1 mg/L

1 KPA = 1000 Pa

1 g/cc = 1000 kg/m³

ABSTRACT

Low salinity waterflooding (LSWF) as a promising EOR technique has recently received a great attention by industry. Such recognition is based on the cost-effectiveness of implementation and the fact that it manages to provide incremental oil recovery. Recently, researchers started to cast an interest on the possible impairment of LSWF with other technologies such as polymer flooding, surfactant flooding, and many others to achieve even higher recovery factor. Thus, combining LSWF with other EOR technology such as CO₂ flooding is suggested as a hybrid process than can possibly improve the overall performance. Injection of CO₂ has advantages such as oil swelling and viscosity reduction which can further improve the oil recovery when combined with LSWF. In this research work, by combining the effects of low salinity water injection and CO₂ flooding, a hybrid approach of Low Salinity Water Alternating Gas injection (LSWAG) is studied numerically. First, a model capturing the geochemical processes of aqueous and surface reactions, ion exchange, and wettability alteration is built at core and large scales. The model is then validated against coreflooding data conducted on sandstone cores obtained from the literature (Shaddel et al. 2014). Afterwards, a set of injection scenarios including, high salinity water injection, low salinity water injection, high salinity WAG, and low salinity WAG are studied and compared at core-scale. Next, an assessment to evaluate the impact of LSWAG on oil recovery in large scale is investigated using a heterogeneous sector model simulation. Results show that LSWAG, as compared to other injection strategies, leads to a higher incremental oil recovery outperforming other techniques at both core and three dimensional sector scales. That is, LSWAG displayed a higher oil recovery of 17% and 13% more than the conventional WAG and waterflooding, respectively. Moreover, a sensitivity analysis was conducted on operational parameters such as WAG ratio, cycling length, and start-up date. Based on the analysis, it is drawn that WAG ratio of 1:1 showed better performance than the 1:5. The cycling lengths of 3, 6, 9, and 12 were simulated in order to observe the impact on oil recovery. No relationship was found between the cycling length and recovery factor. In terms of start-up date of LSWAG, cases that imply injection of low salinity water for period of 2, 5, 7, 10 years consequently followed by LSWAG are presented. An analysis shed light on the observation that the later kick-off of WAG allowed to fully leverage the low salinity effect as it showed highest recovery of 57.6%. The preliminary results obtained from this study define LSWAG as a hybrid EOR approach that can provide additional oil recovery and supports its applicability in hydrocarbon reservoirs. However, additional research is needed on this hybrid process.

TABLE OF CONTENTS

ACKNOWLEDGEMENTS	II
ORIGINALITY STATEMENT	III
NOMENCLATURE.....	IV
ABSTRACT.....	VIII
TABLE OF CONTENTS	IX
LIST OF FIGURES.....	XI
LIST OF TABLES	XII
1. INTRODUCTION.....	1
1.1 Background	1
1.2 Problem definition.....	2
1.3 Relevance to the industry	2
1.4 Objectives of the thesis	3
1.5 Thesis organization	3
2. LITERATURE REVIEW.....	4
2.1 Conventional Water Alternating Gas Injection	4
2.2 Low Salinity Water Injection	5
2.2.1 Experimental Studies.....	5
2.2.2 Modelling and Simulation Studies	7
2.2.3 Field-scale trials	10
2.3 Underlying mechanisms of Low Salinity Water Injection	10
2.3.1 Fines Migration	10
2.3.2 Increase in pH.....	12
2.3.3 Multicomponent Ion Exchange	14
2.3.4 Double Layer Effect	15
2.4 CO ₂ Injection.....	17
2.5 Low Salinity Water Alternating CO ₂ Injection	18
2.6 CO ₂ in the presence of Low Salinity Water	18
2.7 Combined effects of CO ₂ and Low Salinity Water Injection	19
2.8 Experimental studies on Low Salinity Water Alternating CO ₂ Injection.....	19
2.9 Modelling and Simulation of Low Salinity Water Alternating CO ₂ Injection	20
3. PROJECT PLAN	23
3.1 Project schedule.....	23
3.2 Resource requirements	23
3.3 Risk management	23

3.3.1	Physical hazards	24
3.3.2	Project hazard	24
4.	METHODOLOGY	26
4.1	CMG Model	26
4.1.1	CMG-GEM.....	26
4.1.2	Governing Equations.....	27
4.1.3	Geochemical Modeling	29
4.2.3.1	Intra-Aqueous Reactions	29
4.1.3.2	Mineral Dissolution and Precipitation Reactions.....	30
4.1.4	Ion Exchange and Wettability Alteration Models.....	30
4.1.5	Modeling of CO ₂ flooding.....	32
4.2	Validation data	32
4.2.1.	Experimental Materials	33
4.2.1.1	Cores	33
4.2.1.2	Crude oil.....	34
4.2.1.2	Brine.....	34
4.2.2.	Experimental Procedure	35
5.	RESULTS AND DISCUSSION	36
5.1	Validation of the model.....	36
5.1.1	Description of One-Dimensional Model.....	36
5.1.2	Validation Results	38
5.1.2.1	Coreflooding Experiment A4 – Low salinity waterflood using SW	39
5.1.2.2	Coreflooding Experiment A3 – Low salinity waterflood using dFW0.1	40
5.1.2.3	Coreflooding Experiment A2 – Low salinity waterflood using dFW0.01	40
5.2	One Dimensional Simulation of LSWAG.....	41
5.3	Sector Model Simulation of LSWAG	44
5.4	Sensitivity Analysis on LSWAG.....	47
6.	CONCLUSIONS AND RECOMMENDATIONS.....	50
7.	REFERENCES.....	51

LIST OF FIGURES

Figure 2-3. Polar components adhered by fines (Retrieved from Tang and Morrow, 1999)	11
Figure 2-4. Detached fines (Retrieved from Tang and Morrow, 1999)	11
Figure 2-5. Mobilized oil (Retrieved from Tang and Morrow, 1999).....	12
Figure 2-6. Saponification process (Retrieved from McGuire et al., 2005).....	13
Figure 2-7. Concentrations of Mg^{2+} and Ca^{2+} at the effluent during low salinity waterflooding (Retrieved from Lager et al., 2006).....	14
Figure 2-8. Mechanisms of ion exchange during low salinity water injection (Retrieved from Lager et al., 2006).....	15
Figure 2-9. Interaction of COBR system at the presence of low and high salinity water (Retrieved from Xie et al., 2016).....	16
Figure 2-10. Process of detachment during electrical double layer effect (Retrieved from MSc thesis of Cotterill, 2014)	17
Figure 2-11. Oil recovery factor at different scenarios (Retrieved from Dang et al., 2014)	21
Figure 3-1. Thesis schedule.....	23
Figure 4-1. Methodology	26
Figure 4-2. Relative permeability curves during high and low salinity waterflood.....	32
Figure 5-1. The view of one-dimensional model	37
Figure 5-2. Validation of the low salinity water coreflood using SW.....	39
Figure 5-3. Relative permeability curves for A4 experiment (Shaddel et al. 2014).....	39
Figure 5-4. Validation of the low salinity water coreflood using dFW0.1.....	40
Figure 5-5. Relative permeability curves for A3 experiment (Shaddel et al. 2014).....	40
Figure 5-6. Validation of the low salinity water coreflood using dFW0.01.....	41
Figure 5-7. Relative permeability curves for A2 experiment (Shaddel et al. 2014).....	41
Figure 5-8. One-dimensional model of LSWAG	42
Figure 5-9. Comparison of Case 1 (HSW) and Case 2 (LSW)	43
Figure 5-10. Case scenarios	44
Figure 5-11. Ratio of WAG.....	44
Figure 5-12. 3D view of heterogeneous sector model.....	45
Figure 5-13. Oil recovery comparison for all cases	46
Figure 5-14. Water cut comparison for all cases.....	47
Figure 5-15. WAG ratio for both LSWAG and HSWAG.....	47
Figure 5-16. Sensitivity of recovery factor on WAG ratio.....	48
Figure 5-17. Sensitivity of recovery factor on length of cycling period	48
Figure 5-18. Sensitivity of recovery factor on start-up date of WAG.....	49

LIST OF TABLES

Table 3-1. Required resources.....	23
Table 3-2. Risk ranking matrix	24
Table 3-3. Physical hazards.....	24
Table 3-4. Project hazards.....	25
Table 4-1. The core properties (Shaddel et al., 2014)	33
Table 4-2. The mineral composition of cores (Shaddel et al., 2014)	33
Table 4-3. Oil composition (Shaddel et al., 2014)	34
Table 4-4. The injected brine composition (Shaddel et al., 2014)	34
Table 4-5. Experimental results (Shaddel et al., 2014)	35
Table 5-1. Dimensional specifications of one-dimensional model	37
Table 5-2. Input data	37
Table 5-3. Geochemical reactions.....	38
Table 5-4. Dimensional, operational, and petrophysical specifications of the sector model	45

1. INTRODUCTION

The first chapter of this thesis starts with a section on importance of EOR methods in sandstone reservoir with emphasis on CO₂ flooding and Low Salinity Waterflooding (LSWF). Then, it follows with research problem definition and industrial relevance of the proposed research work. The following sub-section covers the objectives of this study. Finally, in the last section one can find the detailed organization of this thesis.

1.1 Background

Worldwide demand for hydrocarbon resources continues to grow as the global population and living standards are steadily increasing (IEA, 2006). Bjorlykke (2010) reports that approximately 60% of all hydrocarbon reservoirs occur in sandstones. Traditionally, only about 10-20% of the liquid hydrocarbon held in the reservoir is extracted during primary oil recovery (Rackley, 2017). Considering their low initial RF, using IOR/EOR techniques is inevitable. The classical waterflooding can be explained as the injection of water designed to extract additional oil and maintain the reservoir pressure. There is no doubt that waterflooding is considered as one of the most successful viable technologies to succeed primary recovery stage. Authors such as Leverette (1941) and Welge (1952) are one of the first pioneers enlightening on the displacement mechanisms during movement of water in the porous media. Traditionally, as the secondary process becomes economically unfeasible, it is followed by the final stage – tertiary recovery that is also known as Enhanced Oil Recovery or EOR. The ultimate stage of production or tertiary recovery includes injection of chemicals, extrinsic materials (liquid or gas), or use of thermal energy to recover additional petroleum in place. An operational process that implies injecting the foreign material into the reservoir to produce additional oil called EOR. The objective of EOR is to extract the oil that cannot be extracted by conventional means reducing the original residual oil saturation. Advantageous environment for increased oil recovery is provided by the interrelation between injected material and crude oil, and mineral. As a result, various physical and chemical mechanisms such as oil swelling, decrease in oil viscosity, lowering interfacial tension, favorable phase behavior, and wettability alteration are induced (Green and Willhite, 1998). Low salinity waterflooding is an EOR technology that gained momentum among the scholars because of its impact on oil recovery and economic viability. The fundamental concept of LSWF is to inject the brine with lower salinity than the formation water in order to secure wettability alteration to a more favorable state. The CO₂ injection is an EOR technique which has been around for several decades and that is deployed

in medium to light oil reservoirs in both sandstones and carbonates. Flooding the reservoir with CO₂ triggers such mechanisms as oil swelling and oil viscosity reduction. However, as the injected gas has low viscosity there is a problem of unfavorable mobility ratio.

1.2 Problem definition

Extensive experimental studies, numerical simulations, and field trials demonstrated that the application of low salinity water injection (LSWF) could provide incremental recovery by altering the wettability. On the other hand, CO₂ flooding has always been a promising IOR method due to its advantages (i.e., pressure maintenance, permeability enhancement, swelling effect, and lowering oil viscosity). With the objective of improving both displacement and sweep efficiencies the idea to combine gas injection with low salinity water injection is proposed here. This process is known as Water Alternating Gas (WAG) injection although not well addressed in the literature. This research work focuses on the hybrid version of WAG – Low Salinity Water Alternating Gas injection. This technique allows to leverage the beneficial effects of both LSWF and CO₂ flooding on oil recovery in hydrocarbon reservoirs. By combining the effects of low salinity water injection and CO₂ flooding, modern approach of Water Alternating Gas (WAG) injection is formulated. Alteration of the wettability towards a water-wet system and improvement of volumetric sweep efficiency can mitigate the issue of low oil recovery in sandstone reservoirs.

There are very few attempts of modelling LSWAG reported in the literature. Another equally important motivation for research arises from the fact that there is a gap in the literature about the contribution of interaction between carbon dioxide and low salinity water. Thus, developing a mechanistic model that accurately represents geochemical interactions in crude oil, brine, and rock system in the presence of CO₂ plays a significant role during the numerical simulation. Further step implies a numerical simulation study of LSWAG in carbonate reservoirs based on the proposed mechanistic model to investigate the impact on oil recovery.

1.3 Relevance to the industry

At present, in Kazakhstan, sandstone reservoirs such as Uzen, Kalamkas, and Zhetybai make up for a vast number of oil and gas fields. Taking into account that these fields surpassed their primary recovery stage, it is to be admitted that further stages should be planned in advance because the proper forecast and right decision making (i.e., selection of appropriate IOR/EOR method) clearly will affect the production from these fields. Hence, extensive studies of

LSWAG in sandstone reservoirs are entirely relevant for the oil and gas industry of Kazakhstan and beyond.

1.4 Objectives of the thesis

To expand the current limits of knowledge on LSWAG based on developing a modeling study, the main objectives of this research work was:

- To understand the fundamental science and the concepts behind the LSWAG. The accomplishment of this objective was of paramount importance, as it constitutes the cornerstone for developing a model and further coupling with the equation-of-state compositional simulator.
- To develop a model of LSWAG under sandstone reservoir conditions. The dominant chemical and physical interactions are to be taken into account to acquire a representative model.
- To assess and evaluate the impact of proposed EOR technique on oil recovery.
- To deliver a sensitivity analysis study on performance of LSWAG from the operational point of view.

1.5 Thesis organization

The first chapter of the thesis is comprised of theoretical background and literature review that covers previously performed scientific work corresponding the topic of our research. The second chapter contains the project plan documentation. In Chapter 3, the methodology to achieve the research objectives is proposed. Chapter 4 represents results and discussions on the development of a model, numerical studies and case scenario analyses. Lastly, in Chapter 5, conclusions and recommendations for future work are presented.

2. LITERATURE REVIEW

This chapter of the thesis includes fundamental concepts and the research reported by other scientists in the literature on various aspects of this research topic. First, a detailed description of the conventional WAG is presented. Then, the previous research on low salinity water flooding (LSWF) that encompasses experimental, modeling, and field trial studies is presented. Afterwards, it is followed by the enlistment and a brief explanation of the underlying mechanisms behind low salinity effect. The fundamental concepts and previous investigations on CO₂ flooding can be found in the following sub-section, as well. Finally, the last sub-sections provides the reader with the both experimental and modeling research on LSWAG reported in the literature. In addition, it includes passages in the combined effects of CO₂ flooding and LSWI, and behavior of carbon dioxide gas in the presence of low salinity water.

2.1 Conventional Water Alternating Gas Injection

During the traditional injection of gas, mobility ratio between gas and oil is unfavorable due to low viscosity of injected phase, and high density contrast between gas and the displaced oil bank. As a result, a considerable amount of oil is bypassed because of the processes such as early breakthrough, anterior instability of fluid, also known as viscous fingering leading to the poor volumetric sweep efficiency.

Water alternating gas injection is considered as a technique developed to overcome the aforementioned issues. This method provides a decrease of mobility ratio of both phases in a porous medium by successive injection of gas and water as a 'chase fluid'. According to Christensen et al (2001), an alternated injection of water and gas provides increased oil recovery promoted by improved volumetric sweep efficiency and better mobility control. Traditionally, hydrocarbon and non-hydrocarbon gases can be used as an injected agent coupled with water. Low molecular weight gases such as methane, ethane, propane, butane are hydrocarbon gases used during WAG. Generally, non-hydrocarbon gases are comprised of carbon dioxide and nitrogen. In terms of regime, if the reservoir pressure is higher than the minimum miscibility pressure of the injected gas, it is classified as a miscible water alternated gas injection process. As for the case when the downhole pressure is lower than the minimum miscibility pressure of the injected gas, it is denoted as immiscible water alternated gas injection.

One of the early works on WAG was done by Caudle and Dyes (1958). Based on experimental studies, they found out that WAG exhibited 30% higher ultimate sweep efficiency than the traditional standalone gas flooding. Christensen et al. (2001) provided a first extensive

review addressing field-scale WAG experience. Authors claim that a common trend constituting improved oil recovery in the range of 5% to 10% was observed in the majority of 60 field cases.

The sound application of WAG ubiquitously depends on factors such as reservoir and fluid characteristics, injection pattern, and operational parameters, including slug size, ratio, and cycles. Christensen et al. (2001) presented that five spot-pattern is the most widely used for WAG. As per injected gas volume, the slug size was mostly in the range of 0.1 to 3 pore volume (PV). The WAG ratio is considered as one of the most crucial parameters during WAG injection. According to the Christensen et al. (2001), the optimal WAG ratio constitutes 1:1.

2.2 Low Salinity Water Injection

Interaction of different physical parameters and factors at microscopic and macroscopic levels plays a significant role in the understanding of oil recovery improvement. Thus, according to the recent studies (McGuire et al. 2005, Lager et al. 2006, Ligthelm et al. 2009), different attempts were devised to understand the complex oil/brine/rock system interrelationships during the low salinity water injection process leading to improved recovery of oil. That is being said, the low salinity water injection technique provoked great interest among researchers because of its beneficial impact on incremental oil recovery and cost-effective implementation. Numerous mechanisms have been proposed to explain the effect of low salinity water injection process on the increase in oil production; nevertheless, the constitutive elaborateness of this technique makes this topic to remain yet controversial.

2.2.1 Experimental Studies

Reiter (1961) first made experimental investigations on the effect of low salinity water injection by the method of water flooding through sand packs. Incremental oil recovery from Nacatosh sandstone oil-wet cores within two scenarios of low salinity water injection (25% of salinity of original Nacatosh connate water) and high salinity water injection (original Nacatosh interstitial water) were evaluated and compared. According to the results, less saline water injection had an average of 12.6% absolute recovery and 21.3% higher ultimate recovery than the high salinity water floods because of clay hydration phenomena.

Bernard (1967) shed a light on the impact on oil recovery of both brine and freshwater that flooded synthetic and natural cores that have clay in their composition. As a result, additional oil recovery and increased pressure drop were observed when the NaCl concentration

was lowered from 1 to 0.1%. At the same time, there was no effect on oil recovery when the NaCl concentration was decreased from 15 to 1%. Buckley et al. (1989) based on the electrophoresis and adhesion tests, showed that wettability alteration is controlled by brine concentration and composition.

Webb et al. (2004) developed an idea of the selection of optimal salinity of brine during waterflooding. Results demonstrate that modification of the composition of invading brine improves recovery factor of traditional waterflooding for 38%. A large body of experimental works (Tang and Morrow, 1997; Morrow et al., 1998; Tang and Morrow, 1999a, 1999b; Zhang and Morrow, 2006; Loahardjo et al., 2010) confirmed advantages of low salinity effects on secondary and tertiary effects.

Even if the topic of mechanisms underlying low salinity effect remains controversial, the effect of wettability alteration towards water wetness is considered as one of the most probable reasons for such positive impact on incremental oil recovery. Several authors performed laboratory studies on wettability modifications as a primary cause of additional oil recovery during low salinity effect (Jadhunandan and Morrow, 1995; Tang and Morrow, 1999a; Vledder et al., 2010; Austad et al. 2012).

The set of coreflooding experiments (Patil et al., 2008; Rivet 2009) demonstrated the positive effect of low salinity water injection on oil recovery. In the work of Robertson (2010), the Minnelusa and Green river formation core samples were used in flooding test with the objective of identifying the low salinity effect. Results showed that, at elevated ageing temperatures, injection of low salinity water resulted in noticeable higher oil recovery than the formation brine.

However, according to the literature, not every study support the positive effect of low salinity water injection on incremental oil recovery. Thyne and Gamage (2011) conducted studies on the same formation as Robertson (2010) and came up that there was no any beneficial effect on the oil recovery as the salinity of injected brine was reduced. Skrettingland et al. (2010) reported that based on the coreflooding and SWCTT low salinity effect was not observed as the original wettability of the reservoir was already favorable.

Some review papers were published in order to revise and report on the state of the low salinity water injection from various perspectives. One of the latest reviews constitutes a work by Bartels et al. (2019) where framework based assessment of mechanisms of low salinity effect is addressed. Authors propose a holistic approach which further can assist in acquiring the

predictive ability and screening tool development. Chavan et al. (2019) produced a review that is mainly focused on the screening criteria for low salinity water injection. A summary of possible mechanisms for both sandstones and carbonates is addressed. It also briefly covers the synergistic approach of polymer aided low salinity waterflooding. A review by Hao et al. (2019) aims to put stress on the explanation of the various acting phenomena responsible for the low salinity effect, especially in carbonate reservoirs. Compared to other reviews, it gives a discourse on the flow driven occurrences such as fluid diversion and emulsification. Derkani et al. (2018) presented a review paper on low salinity waterflooding that embarks studies on carbonate reservoirs. Wang and Fu (2018) presented a comprehensive data-driven review on the experimental studies of low salinity waterflooding in sandstones. They stated that there is a solid relationship between wettability alteration caused by low salinity effect and incremental oil recovery. Sheng (2014) provided the reader with a comprehensive review on low salinity waterflooding. Namely, it covers such areas as history, experimental studies, field-scale cases, desired initial conditions, governing mechanisms, and simulation of low salinity water injection.

2.2.2 Modelling and Simulation Studies

One of the first attempts at modelling the low salinity waterflooding is presented by Jerauld et al. (2006). Authors documented that wettability results from the salinity dependent relative permeability functions of oil and water phases. They used the numerical dispersion technique to mimic the physical dispersion because of the interaction of the injected low salinity water and connate water. However, this work does not include any geochemical parameters dedicated to representing various reactions taking place during the low salinity water injection and model was based on the linear relation of salinity and residual oil saturation.

Wu and Bai (2009) introduced a mathematical model to simulate the flow and transport behavior during the low salinity waterflooding in the fractured reservoirs. According to assumptions, a salt component is included in the aqueous phase and transported by means of advection and diffusion in the porous and fractured media. The multi-domain technique was adopted to capture the interactivity of salt between free and stagnant water zones, whereas discrete-fracture modelling was used to model the fractured rock. Wu and Bai's conceptual model can be incorporated into the reservoir simulator to model low salinity effect in the fractured reservoirs. Andrianov and Nick (2019) demonstrated a numerical simulation of the low salinity water injection in the fractured chalk outcrop-based models. The Discrete Fracture Matrix (DFM) approach is utilized in order to introduce fractures as a low-dimensional finite

volume. The transport solver is accompanied by the PhreeqcRM of Parkhurst and Wissmeier (2015) in order to acquire thermodynamic equilibrium for the water phase whereas low salinity water injection was modelled as two-phase oil and water immiscible displacement.

Sorbie and Collins (2010) proposed a semi-quantitative pore-scale physical model of the low salinity water injection effect. Their pore-scale model calculations highlight the origins of multicomponent ion exchange as a mechanism as well as the size of the effect and a number of predictions for further study. Another work by Wilmott et al. (2020) included the dynamic network model covering ion exchange mechanisms that provoke salinity-dependent slip constraints on the interface between oil phase and mineral surface. Their main assumptions include that thickness of a thin wetting film that dissociates oil and rock surface is reliant on the salinity of the water; porous medium is comprised of a number of pores and throats, and there is one phase that is adhered to the mineral surface and other two flowing through the pores. As compared to the study of Knudsen et al. (2002), a saturation of each phase is defined, and the conductivity of pore throat is calculated as a function of saturation.

One-dimensional mathematical ion exchange model designed for examining low salinity waterflooding experiments was presented by Omekeh et al. (2012). Authors studied the dissolution and precipitation of carbonate minerals and the impact of multiple ion exchange mechanism on the flow characteristics of both water and oil phases. Further, the mechanistic model was validated against experimental work of Fjelde et al. (2012). It was investigated that improved relative permeability of oil phase was caused by the release of divalent cations from the mineral surface. The study of the effect of both multi-component ion exchange and mineral dissolution and precipitation on pH level, and release of Ca^{2+} and Mg^{2+} cations was addressed in this work.

Al-Shalabi et al. (2015) designed a mechanistic model to capture the effect of low salinity water injection using UTCHEM simulator. According to the proposed model, wettability alteration is caused by the trapping parameter and contact angle value. Based on the results, the model showed good consistency with the laboratory studies. Korrani et al. (2013) also utilized UTCHEM simulator, but they coupled it with the Iphreeqc. They claimed that no matter what is the mechanism that induces wettability alteration the essential factor concerns ions. Thus, they connect the wettability of the rock with the geochemistry of the brine and mineral interfaces. They provide an algorithm of modelling solved by the implicit in pressure and explicit in the saturation method. However, there is no information on the validation of the proposed model with the existing experimental study.

The modelling study by Qiao et al. (2015) included a reaction network generated to track the surface reactions between a radical group, positively charged ions, and sulfate. Then, it was followed by experimental validations based on Stevns Klint chalk. Authors concluded that wettability alteration is governed by the surface-complexation reactions, and oil recovery is mainly reliant on the specific conditions but not from contact angle (Al-Shalabi et al. (2014)).

Qiao et al. (2016) extended their previous model (Qiao et al. (2015)) and added mineral dissolution reactions to consider the presence of anhydrite within the mineralogy of the reservoir rock. As authors highly focus on the mineralogy, they incorporated both aqueous and surface complexation, dissolution and precipitation of the carbonate minerals such as CaCO_3 and CaSO_4 . Further, geochemical parameters, coupled with the multi-phase transport, are included in the in-house simulator. Effluent concentrations of sulphate anion, two divalent cations (Ca^{2+} and Mg^{2+}) from the simulation results exhibited good agreement with the chromatographic wettability tests.

An extensive study on mechanistic modelling of low salinity waterflooding was made by Dang et al. (2016). Firstly, the ion exchange model was validated using geochemistry software PHREEQC. Secondly, the proposed model was posed against laboratory studies of Fjelde et al. (2012) and Rivet (2009) for the North Sea and Texas reservoirs correspondingly. This model included various aspects such as both aqueous and mineral reactions, ion exchange and wettability alteration models. In terms of wettability alteration, authors' observations indicate that the shift of relative permeability curves is caused by the adsorption of the Ca^{2+} divalent cation compared to the findings of Omekeh et al. (2012). A closed-loop systematic workflow that is able to consider critical geological effects during the low salinity water injection is designed to predict the field-scale performance.

One of the latest works on the mechanistic modelling of low salinity water injection is presented by Korrani and Jerauld (2019). Authors used detailed colloidal science in order to model the wettability alteration by connecting the rock state (wettability) with the chemical properties of the injected water. Here, the work of Korrani et al. (2013) was further extended, and the wettability change model was improved. Results produced by UTCOMP-IPhreeqc coupled reservoir simulator were validated against a number of experimental works by Kozaki (2012), Shehata et al. (2014), Yousef et al. (2010), Zhang and Austad (2006), and lastly Fathi et al. (2010).

2.2.3 *Field-scale trials*

A considerable amount of field pilot tests were run in order to evaluate the performance of low salinity water injection, and advantages of low salinity effects on secondary and tertiary effects were confirmed (McGuire et al., 2005; Lager et al., 2008). Single-well chemical tracer tests (SWCTT) and field trials in the North Slope reservoir indicated the drastic reduction of the residual oil saturation (McGuire et al., 2005). A secondary flood application of low salinity water injection in the Omar field provided a full alteration of wettability and exhibited additional oil recovery of 10 to 15% of the STOIP (Vledder et al., 2010). However, Mahani et al. (2011) presented 2D conceptual models of low salinity water injection in Omar and Sijan fields in both secondary and tertiary modes. Field responses show that there was a possible wettability change due to low salinity water injection in Omar field compared to Sijan field that did not provide any clear response.

2.3 Underlying mechanisms of Low Salinity Water Injection

Due to complex rock, fluid, and brine interactions, the issue of defining underlying mechanisms of low salinity effect is still considered to have controversial ideas among researchers. Several mechanisms are proposed to explain the advantage of low salinity waterflooding compared to a conventional one. Nevertheless, according to the extensive studies in the literature, the following four of them are widely discussed.

2.3.1 *Fines Migration*

Tang and Morrow (1999) concluded from several experimental waterflooding that phenomena of increased oil recovery led by injection of low salinity water is primarily controlled by crude oil, rock, and brine interactions. Two types of oil were used: CS crude oil and refined oil. Synthetic reservoir brine, synthetic seawater, and their dilutions were used as the injected fluid. A positive effect was observed when low saline brine was injected through unfired and iron removed Berea sandstones fully saturated with reservoir oil. They documented that the mobilization of fines is considered as a mechanism behind low salinity effect. Incremental oil recovery is observed when the following conditions are met: initial water saturation, the presence of potentially movable clay particles, and adsorption of polar components of oil.

Initially, oil components of oil are adsorbed on the interface of minerals and particles of heavy oil are adhered by clay minerals coating the rock grains. As the injected brine with lower ionic strength interacts with clay, the former one is destabilized. As a result, clays adhering oil

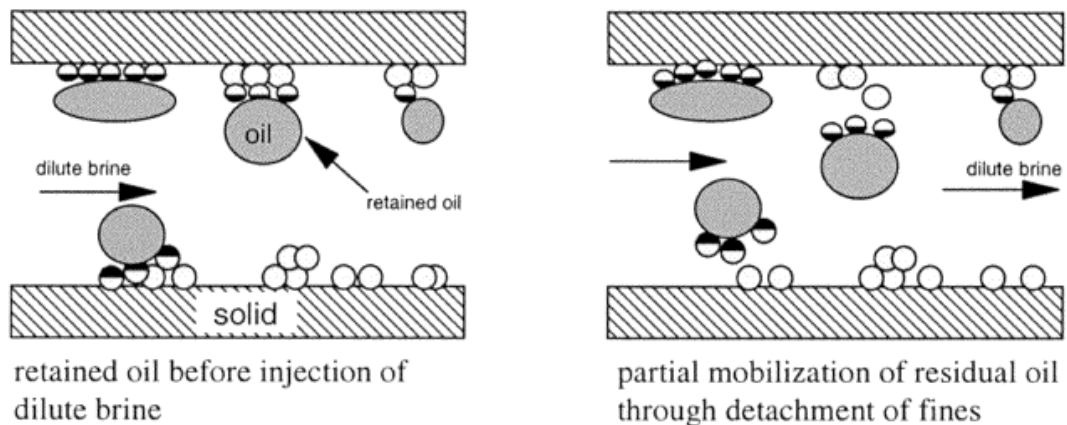

Figure 2-3. Mobilized oil (Retrieved from Tang and Morrow, 1999)

Nonetheless, a number of experimental studies performed by Lager et al. (2006) demonstrated that incremental oil recovery by low salinity effect did not include any signs of fines migration nor significant permeability reduction. Other laboratory findings also contradict the theory of fines migration (Zhang and Morrow, 2006; Zhang et al., 2007). Reservoir scale experimental attempts to study low salinity effect by Lager et al. (2008) show that no side effects such as clay swelling and pore plugging prompted by mobilization of fines were observed.

2.3.2 Increase in pH

McGuire et al. (2005) claim that behavior of smart water injection on core scale including crude oil, brine, and rock interactions, wettability alteration effect is alike during alkaline flooding and surfactant flooding. According to the studies, generation of surfactants from trapped oil at increased pH levels considered as a major mechanism of low salinity effect. Interaction of low salinity water and reservoir rock minerals form hydroxyl ions and elevate pH from the 7 up to more than 9.

Increased oil recovery during low salinity water injection is caused by IFT reduction between oil and water, change of wettability driven by elevated pH levels. Moreover, the in-situ formation of surfactants during the interaction between oil and low saline water having high pH is observed (saponification of acid or polar components of oil). The process of saponification can be described by following formulas shown on Figure 2-6.

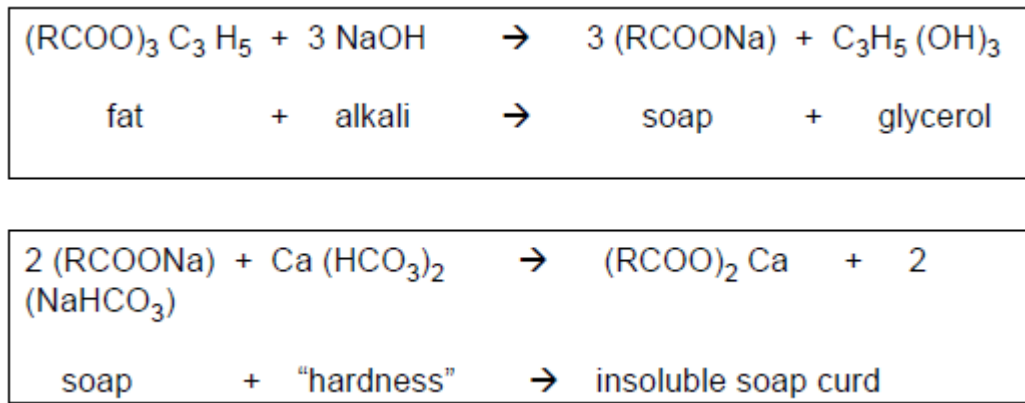
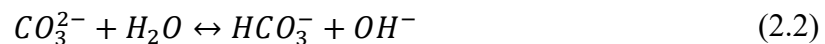

Figure 2-4. Saponification process (Retrieved from McGuire et al., 2005)

Generally, in high salinity systems, decreased oil recovery is caused by precipitation of surfactants. This problem is solved by the introduction of low salinity water having a low concentration of divalent cations like calcium and magnesium.

Two associated reactions causing elevation of pH level during low salinity effect: carbonate dissolution and cation exchange are presented by Lager et al. (2006).



Amount of carbonate material present in the reservoir rock controls the relatively slow dissolution reactions. Ion exchange and excess of OH^- during the interaction of injected brine and fines are caused by the dissolution of carbonates. Transfer of H^+ present in the water phase and previously adsorbed cations on the mineral surface lead to the elevation of pH level.

However, experimental studies of Lager et al. (2006) cast doubt on increased oil recovery prompted by low salinity effect due to pH increase. Authors claim that coreflooding experiment on North Sea reservoir having the best result of 40% increase in oil recovery during low salinity waterflooding had the crude oil with the acidic number (AN) of 0.05 that is definitely very low. As stated by Ehrlich and Wygal (1977), cut off value of $AN > 0.2$ is required to form surfactants inducing wettability alteration and generation of emulsions. Furthermore, it is reported that a pH level of 7 is enough to observe the low salinity effect. That is why an increase in pH cannot be considered as a major mechanism of low salinity waterflooding.

2.3.3 Multicomponent Ion Exchange

Lager et al. (2006) reported evidence of multicomponent ion exchange mechanism during a geochemical analysis of the effluent after the coreflood of North Slope sample. Although injected brine had the lower salinity than the residual one, results demonstrated a drastic fall of concentration of divalent cations (Mg^{2+} , Ca^{2+}) as it is shown in Figure 2-7. Mentioned phenomena can be explained by the notion that Mg^{2+} and Ca^{2+} are adsorbed by the surface minerals of the rock. Traditionally, all the ions of injected brine undergo a competition for the surface mineral exchangers as it exhibits particular affinity for positively charged ions. The idea of ion exchange within the means of tertiary recovery was first introduced by Pope et al. (1978), Lake and Helfferich (1978), Hill et al. (1978). Valocchi et al. (1981) documented the field-scale trial evidence of ion exchange. Studies included the injection of freshwater into the saline aquifer. As a result, observations on the control wells showed the low concentration of divalent cations compared to the invaded brine and residual water.

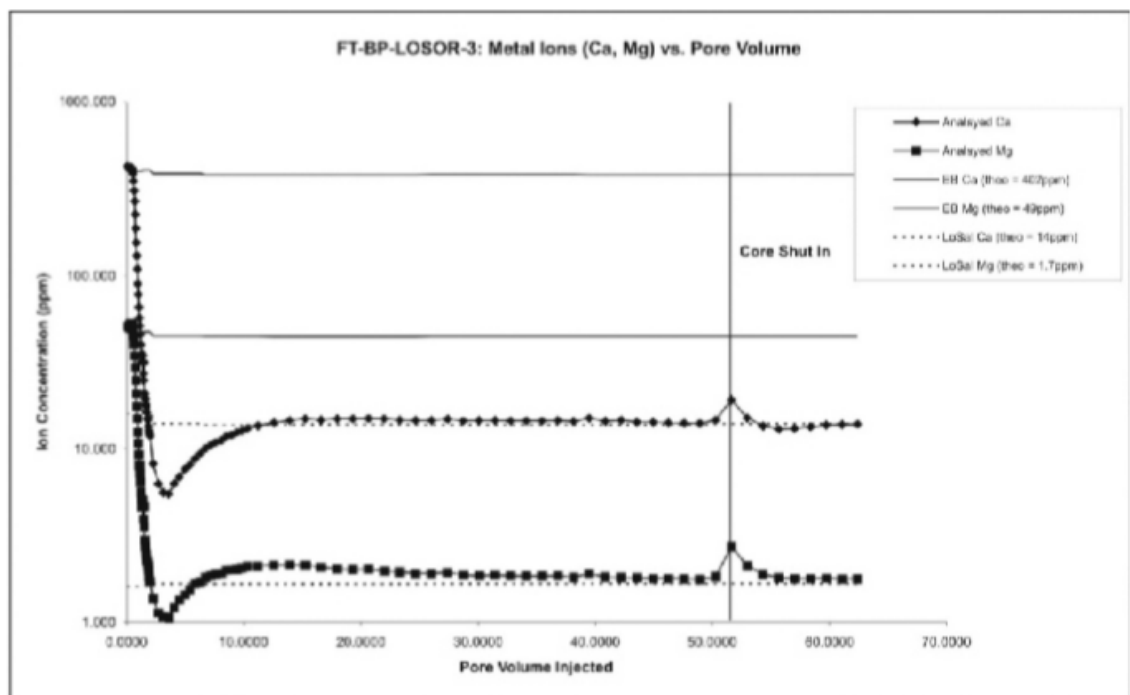

Figure 2-5. Concentrations of Mg^{2+} and Ca^{2+} at the effluent during low salinity waterflooding (Retrieved from Lager et al., 2006)

Eight various mechanisms of attachment of organic particles on top of clay surfaces were proposed by the extended theory of colloids (Amarson and Keil, 2000) and Sposito (1989). Lager et al. (2006) claim that only four of them are affected by ion exchange during low salinity

water injection. As it is shown in Figure 4.6, these are cation exchange, ligand bonding, and cation and water bridging.

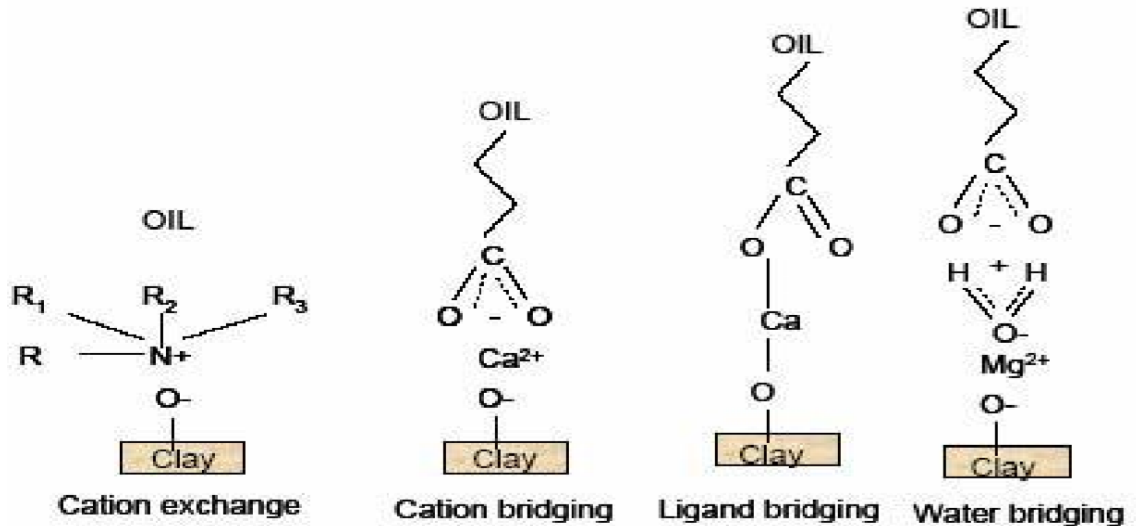

Figure 2-6. Mechanisms of ion exchange during low salinity water injection (Retrieved from Lager et al., 2006)

Wettability alteration towards oil-wetness is achieved by generation of organometallic complexes as multivalent cations are bonded to the heavy compounds of oil. Simultaneously, oil-wetness is enhanced when polar components adhere to the mineral surface and then the most unstable cations are displaced. At this stage, monovalent cations replace heavy compounds and organometallic complexes, and they are released from the rock surface. Correspondingly, incremental oil recovery will be prompted by wettability alteration towards water-wetness achieved by stripping of polar oil particles.

2.3.4 Double Layer Effect

Ligthelm et al. (2009) proposed the idea of double-layer effect as a possible mechanism behind low salinity effect. The theory of double layers is about forces between charged interacting surfaces within the presence of a liquid phase (Sheng 2014).

Traditionally, the electrical double layer is generated when negatively charged clays attract the multivalent metal cations (Ca^{2+} , Mg^{2+}), then fines are connected with negatively charged oil components. The inner layer is composed of adsorbed positive ions, whereas the outer one is made of negative ions. The degree of so-called “width” of the electrical double layer is controlled by the electrolyte content of the water situated around the double layer. If

water has high salinity, the double layer is compact. On the other hand, if the surrounding water has low salinity, which consequently means low ionic strength, the double layer is expanded.

Screening potential of the cations is reduced by lowering the ionic strength through decreasing the salinity of the brine and lowering the concentration of the bivalent cations in the solution. The interaction of low ionic strength brine with double layer leads to the expansion of the former one. As a result, fines are destabilized, and increase of zeta potential is observed. At this stage, monovalent cations such as Na^+ displace the multivalent ones. Afterwards, an increase of repulsive forces between fines and oil is observed. As the repulsive forces overcome the binding forces owing to the multivalent cation bridges, adhered polar components of oil are detached from the surface of mineral leading to the alteration of the wettability to the water wet (Myint et al., 2015, Hiler et al., 2015). Further increase in repulsive forces leads to formation damage, as the clays are detached from the rock surface it blocks the pore throats (Ligthelm et al., 2009).

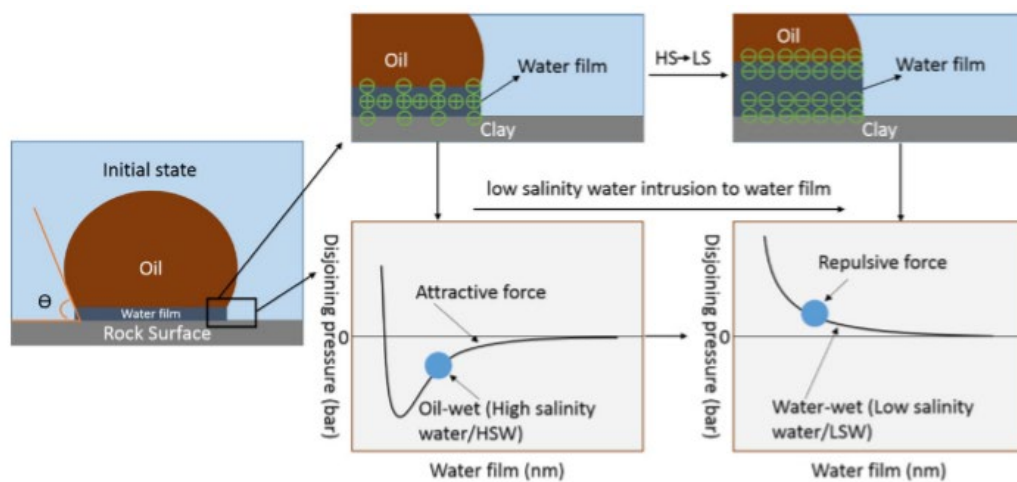

Figure 2-7. Interaction of COBR system at the presence of low and high salinity water (Retrieved from Xie et al., 2016)

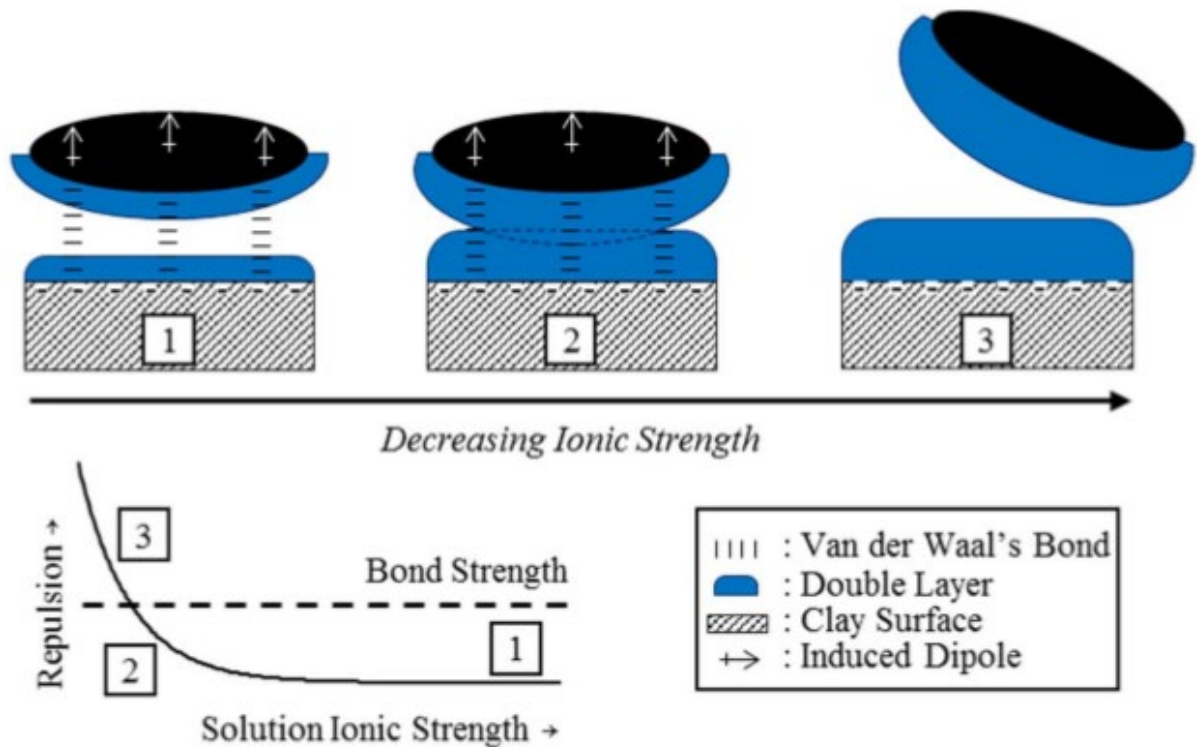

Figure 2-8. Process of detachment during electrical double layer effect (Retrieved from MSc thesis of Cotterill, 2014)

2.4 CO₂ Injection

The success of CO₂ injection was proved by years of research and field implementations (Ghedan, 2009, and Grigg and Schechter, 2018). Favourable incremental oil recovery conditions are created during CO₂ injection. As gas is injected into the reservoir, it interacts with the rock and crude both chemically and physically. Following mechanisms are induced during this process: elimination of interfacial tension between oil and injected fluid, reduction of oil viscosity, oil swelling, and favorable change of phase behavior (Bon et al., 2005). Depending on the reservoir and operational conditions, CO₂ injection can be subdivided into miscible (Holm, 1986) and immiscible displacement (Danesh, 1998 and Jarrel et al., 2002).

CO₂ becomes miscible with crude oil under specific pressure and temperature conditions. The pressure needed to establish miscibility is called minimum miscibility pressure. The value of minimum displacement pressure is governed by the composition of the crude oil and injected gas, also is it a function of reservoir parameters such as pressure and temperature. According to the development stage, miscibility displacement processes are traditionally classified as first-contact miscible (FCM) or multiple-contact miscible (MCM). During the FCM, as gas interacts with the crude oil; a single phase is formed. When it comes to MCM

process, miscibility is achieved by compositional alteration of both gas and crude oil along the movement through porous media (Green and Willhite, 1998).

As long as geologic conditions and extremely low reservoir permeability dictate that application of waterflooding is not viable, incremental oil recovery can be provided by immiscible CO₂ injection. Even if the injected gas is not miscible with the crude oil and MMP is not reached, mechanisms such as oil swelling and decrease of oil viscosity are triggered. Another application of the immiscible CO₂ flooding is to maintain the reservoir pressure (Perera et al., 2016).

2.5 Low Salinity Water Alternating CO₂ Injection

Beneficial effects of the synergistic approach of LSWAG were proved by several laboratory studies (Aleidan et al., 2010; Jiang et al., 2010; Zolfaghary, 2013; Teklu, 2016; Al-Quraishi et al., 2017; Al-Abri et al., 2018). It has been well documented that reduction of residual oil saturation by wettability alteration towards favorable wetness is caused by low salinity effect (Jadhunandan and Morrow, 1995; Tang and Morrow, 1999a; Vledder et al., 2010). At the same time, alternating water gas (WAG) has been widely implemented in the industry to control the mobility of both crude oil and injected gas for an extensive period of time. Combined effects of both techniques create desirable conditions for incremental oil recovery.

2.6 CO₂ in the presence of Low Salinity Water

Studying the behavior of carbon dioxide in the presence of low saline brine is crucial as the developing representative mechanistic model is one of the focuses of research. A number of experimental investigations, correlations and models (Caroll et al., 1991; King et al., 1992; Chang et al., 1998; Duan and Sun, 2003; Duan et al., 2005; Portier and Rochelle, 2005; Tawfiq et al., 2010) were developed to determine the impact of brine salinity on the CO₂ solubility. Theoretical models proposed by Duan et al. (2003, 2005) and Chang et al. (1998) in the list of widely used ones. The common concept implies that solubility of carbon dioxide increases as the salinity of the brine decreases. However, there is not any concordance within the literature in terms of the impact of low saline brine during CO₂ flooding. One may consider that as more gas is prone to be diffused into the water phase, the less amount of gas will in contact with the oil so that recovery is reduced. On the other hand, Stalkup (1970) reported that molecular diffusion of gas into the brine could possibly recover stagnant oil blocked by a water barrier.

Do and Pinczewski (1992) discussed how carbon dioxide diffused into the water phase and reached out stuck oil.

2.7 Combined effects of CO₂ and Low Salinity Water Injection

The combined impact of LSWAG includes wettability alteration effect delivered by low salinity water flooding mechanisms such as multicomponent ion exchange and electrical double effect, whereas the presence of CO₂ provides oil swelling and reduced oil viscosity. Moreover, an increase in the magnitude of CO₂ solubility and diffusion is achieved during the interaction of low saline water with CO₂. Compared to conventional WAG, LSWAG may solve the issue of delayed oil production (Dang, 2014). Another point is improved volumetric sweep efficiency achieved by the reduced absolute permeability during stripping of clay minerals.

2.8 Experimental studies on Low Salinity Water Alternating CO₂ Injection

One of the first attempts to investigate the salinity effect during the WAG process on heterogeneous carbonate cores with Texas oil was made by Aleidan and Mamore (2010). Experimental studies evaluated the effects of invading water with 20 wt. % and 6 wt. % salt concentration during both simultaneous water and CO₂ injection (SWAG) and water alternating CO₂ injection (WAG) operations. As a result, low salinity water injection demonstrated greater oil recoveries of 9 and 12.5% than high salinity brine. The key mechanisms underlying such positive impact on oil recovery were the following: increase in CO₂ solubility led by a decrease in salinity and wettability alteration effect towards favorable wetness during low salinity effect.

An experimental study performed by Jiang et al. (2010) shows that incremental oil recovery was attained as the salinity of invading brine increased. Such controversial results are because strongly water-wet sandstone core with low clay content was deployed. It is known that original wettability of the reservoir rock and content of clay minerals play a significant role during low salinity effect.

Zolfaghary et al. (2013) presented results of core flooding experiments on both secondary and tertiary modes performed to study the effect of low salinity water during the WAG process on sandstone cores with heavy oil. Ultimate recovery from low salinity WAG was 18% greater than high salinity WAG.

Teklu et al. (2016) evaluated effectiveness of LSWAG on two low-permeability carbonate, and medium permeability Berea sandstone cores. Core flooding experiments included typical seawater injection, followed by low salinity water injection, followed by CO₂

flood. Results show that each of these operations yielded the incremental recovery of 14, 25, and 38%, respectively.

The work of AlQuraishi et al. (2017) demonstrates that low salinity water miscible WAG exhibited greater ultimate recovery of 18% than high salinity water miscible WAG on Berea sandstone.

Laboratory studies to investigate applicability and performance of LSWAG on sandstone reservoirs were made by Al-Abri et al. (2018). Results demonstrate that residual oil mobilization was prompted by wettability alteration aided with IFT reduction and mobility control during LSWAG process. Three low saline brines were tested to study the effect of cationic composition on oil recovery. The highest incremental oil recovery was achieved by 5000 ppm NaCl solution compared to $MgCl_2 \times 6H_2O$ and KCl solutions with the salinity of 5000 ppm.

2.9 Modelling and Simulation of Low Salinity Water Alternating CO₂ Injection

Dang et al. (2014) proposed a one-dimensional simulation model to mimic the process of LSWAG. Simulation study included the application of scaled ion exchange equivalent fraction to generate a wettability alteration effect in the heterogeneous 1D model. At the same time, considering ion exchange and properties of clay, realistic relative permeability curves were generated. These four aqueous and mineral reactions taking place during the simulation of LSWAG process:

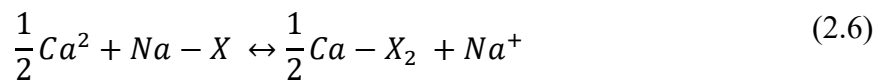
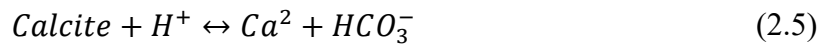
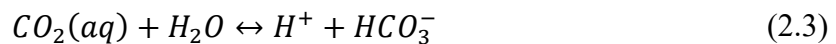

A series of simulation scenarios of high salinity water injection, low salinity water injection, HSWAG, and CO₂ flooding were compared with the performance of LSWAG. The highest recovery of approximately 75% was indicated during LSWAG process.

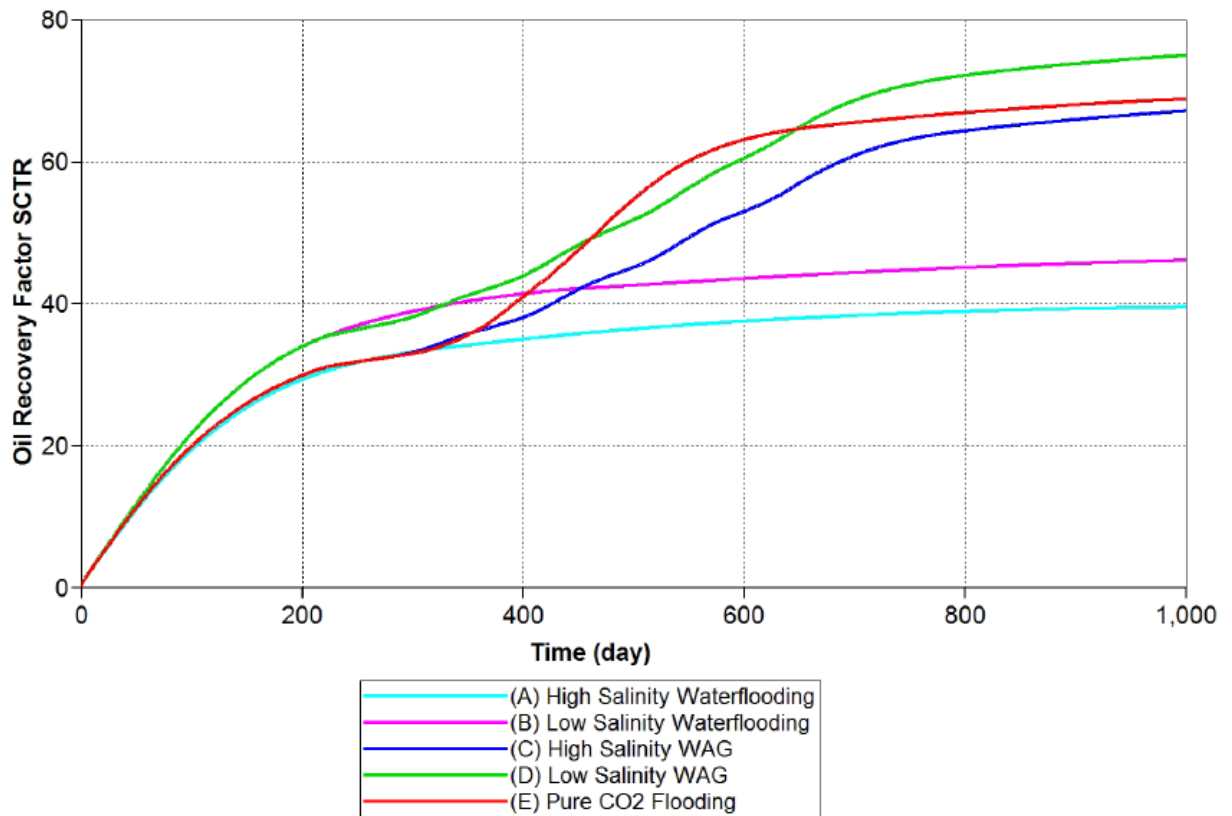

Figure 2-9. Oil recovery factor at different scenarios (Retrieved from Dang et al., 2014)

With the objective of studying the effect of LSWAG on incremental oil recovery on the larger extent, Dang et al. 2014 performed field-scale modelling and simulation of LSWAG operation. Brugge field was introduced as a typical North Sea sandstone reservoir in order to evaluate and assess LSWAG. Critical geochemical processes such as ion exchange and wettability alteration effect were incorporated into the model. Simulation study included sensitivity analysis and preliminary uncertainty evaluations. Incremental oil recovery of 4.5% of OOIP during LSWAG was observed compared to HSWAG.

Extensive studies of LSWAG injection in carbonate reservoirs were performed by Awolayo et al. (2019). A reactive transport model was adopted to predict the series of low salinity water alternating CO₂ flooding experiments on carbonate rocks. It included the application of surface complexation reactions (SCR) with a transport equation to describe the dynamic balance between mineral exchange sites and monovalent ions of injected brine. During

the simulation examinations, it was investigated that thermodynamic parameters mentioned in the literature were not suitable for carbonate rocks.

Model results demonstrated incremental oil recovery of 28% greater than formation water flooding whereas simulation data showed that such advantageous impact on recovery factor was prompted by the reduction of IFT during the in-situ formation of carbonated water led by high solubility of CO₂. Afterwards, the model was applied to assess different injection scenarios on the field scale. LSWAG injection showed significantly higher injectivity and greater oil production.

Naderi and Simjoo (2019) carried out another numerical study of low salinity water alternating gas injection. EOR potential of LSWAG was investigated by the joint analysis of both geochemical and fluid flow modelling. Results indicated that the contrast of ionic strength between formation and injected brine resulted in multicomponent ion exchange between injected water and rock surface, which consequently led to the wettability alteration effect. Increased oil recovery of LSWAG accounted for 10% greater value than high salinity alternating gas injection.

the standard risk assessment tools is WRAC analysis that uses a 5x5 likelihood-consequence matrix. Table 1 illustrates the risk rating from low to extreme cases. Risk ranking matrix

Table 3-2. Risk ranking matrix

Risk matrix		Consequence					Risk rating	
		Negligible	Minor	Moderate	Major	Catastrophic		
Likelihood		1	2	3	4	5		
Almost certain	5	6	7	8	9	10	Extreme	≥ 8
Likely	4	5	6	7	8	9	High	7
Possible	3	4	5	6	7	8	Medium	5-6
Unlikely	2	3	4	5	6	7	Low	≤ 4
Very unlikely	1	2	3	4	5	6		

3.3.1 Physical hazards

A physical hazard is a factor that can harm a person's mental or physical condition without the need for physical contact. The possible physical dangers that can occur during the thesis work and the ways of avoiding them are given in Table 3.

Table 3-3. Physical hazards

Physical Hazard	Description	Risk rating	Risk Control
Eye-strain	Fatigue of the eyes due to a prolonged presence in front of the computer screen	7 High	Regular exercise for eyes, regular breaks while using the computer
High stress	Irritation from the overwork	5 Medium	Good study/relax balance, proper time management
Illness	Disease from mild colds to flu	5 Medium	Maintain immunity of the body, dress warmly at cold conditions

3.3.2 Project hazard

Project hazards are the factors that can affect to the provision of the thesis on time due to unexpected situations.

Table 3-4. Project hazards

Project hazard	Description	Risk level/rating	Risk control
Sudden computer crash	Accidental fall to the floor	3 Low	Obligatory carrying in a bag
Thesis related documents loss	Sudden failure of the hard drive, computer crash due to viruses, not saving the thesis files	5 Medium	Use cloud services like google drive, do not forget to save, installation of anti-virus software
Change of thesis supervisor	A supervisor may be unable to continue student supervision due to some circumstances	5 Medium	Advice with co-supervisor or another professor competent in student's thesis topic
Software inaccessibility	Access to CMG	5 Medium	Contact support center
Lack of experimental data	No experimental data to validate the model	5 Medium	Reach out another technical paper containing information needed for the validation of the model

4. METHODOLOGY

As it was highlighted in the previous chapters of this thesis (refer to the Chapters 1 and 2), there is a clear scarce of research in the field of numerical simulation of LSWAG. Thus, setting a representative model of the LSWAG process and exploring the influence of the proposed hybrid EOR technique on oil recovery are the main concerns of this research. To do so, we should review the key mechanisms of low salinity effect and analyze the behavior of each component of the crude oil, rock, and brine system within the presence of CO₂. Based on these studies, we propose a model that takes into account all the related geochemical reactions, a mechanism that provides wettability alteration, and relative permeability modification induced by wettability alteration phenomenon. Once a model is built in the CMG GEM then, a one-dimensional model is built and validated against existing coreflooding experiments. Finally, the 1D model was extended to a heterogeneous sector model to track the effect of LSWAG on oil recovery in a larger extent.

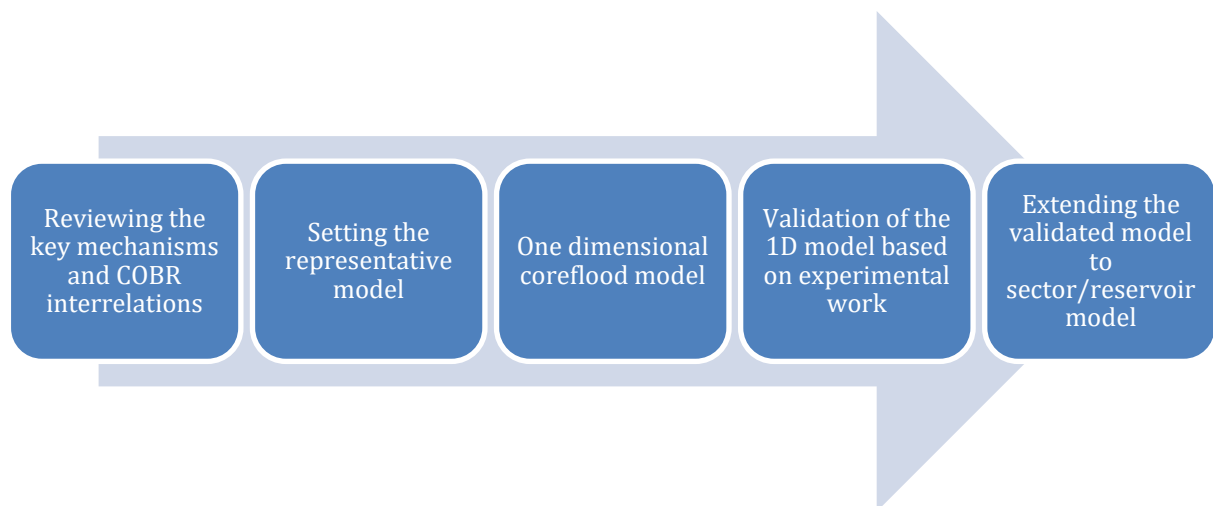

Figure 4-1. Methodology

4.1 CMG Model

4.1.1 CMG-GEM

General Equation of State Model (GEMTM) is a compositional reservoir simulator platform which is provided by a Computer Modeling Group Ltd. This simulator's capacity encompasses but not limited to the wide range of application areas such as modelling conventional recovery stages, sophisticated chemical EORs, and geo-mechanic factors as well as horizontal and multi-lateral wells. That's being said, the main reason to utilize CMG GEMTM is the ability to capture

and simulate complex geochemical reactions and take into account phase behavior of all related components. All the fundamental equations incorporated into the CMG GEM™ can be found in the studies of Nghiem et al. (1989, 2004a, 2004b, 2009, 2011), Nghiem (1999), and Thibeau et al. (2007) and presented in the following sections.

4.1.2 Governing Equations

The cornerstone of the reservoir simulation, Darcy's law, comprises a linear relationship between the rate of the fluid flow within the porous media and potential gradient. Following differential equation expresses the single-phase, one-dimensional flow as follows (Lake, 1989):

$$\frac{q}{A_x} = u_x = -\beta_c \frac{k_x}{\mu} \frac{d\Phi}{dx} \quad (4.1)$$

Where,

q = flow rate

A = cross-sectional area

u = superficial velocity

β_c = unit conversion factor for the transmissibility coefficient

k = absolute permeability

μ = fluid viscosity

Φ = fluid potential

x = distance in the x direction

Following assumptions and limitations are to be taken into account when using aforementioned form of Darcy's law:

1. Homogenous, single-phase, Newtonian fluid
2. Fluid and the porous medium are not in the chemical interaction
3. Laminar-flow conditions
4. Permeability is not the function of pressure, temperature, and the fluid that flows
5. Klinkenberg's phenomenon is ignored
6. The electrokinetic effect is ignored

Extended form Darcy's law for the multiphase flow is shown below:

$$\vec{u}_p = -\beta_c \frac{k k_{rp}}{\mu_p} (\vec{\nabla} p_p - \gamma_p \vec{\nabla} Z) \quad (4.2)$$

Where subscript p stands for the water, oil, gas phases and $k_{rp}, \mu_p, p_p, \gamma_p =$ relative permeability, viscosity, pressure, fluid gravity for phase p .

The key constraints of compositional modelling include but not limited to mass conservation, fugacity equalities, and chemical reaction equations. The primary assumption is that phase equilibrium exists within all related fluid phases. Oil, water, both organic and inorganic gases, ions, and dissolved reliable components are taken as a fluid species. Mineral components, adsorbed cations are in the list of solid species. The universal mass conservation equation for fluid component a and solid component m looks as follows (Lake, 1989, and Steefel and MacQuarrie, 1996):

$$\begin{aligned} \frac{\partial}{\partial t} \left(\sum_{j=1}^{n_p} (\varphi p_j S_j X_{aj}) \right) + \nabla \cdot \sum_{j=1}^{n_p} (p_j X_{aj} u_j - p_j \varphi S_j D_{aj} \nabla X_{aj}) + q_a^W \\ = \sum_{k=1}^{n_k} v_{ak} r_k + \sum_{q=1}^{n_q} v_{aq} r_q \end{aligned} \quad (4.3)$$

$$\frac{\partial C_m}{\partial t} = \sum_{k=1}^{n_k} v_{mk} r_k + \sum_{q=1}^{n_q} v_{mq} r_q \quad (4.4)$$

Where,

t denotes time; n_p stands for a number of fluid phases; φ is porosity; p_j and S_j are density and saturation of phase j ; X_{aj} is the molar fraction of fluid species a in phase j , u_j is Darcy velocity for corresponding phase j , D_{aj} is the dispersion tensor for component a in phase j , q_a^W is the rate of well for component a , solid component concentration is expressed as C_m , stoichiometric coefficients of component a in kinetic reaction k are described as v_{ak} , v_{aq} are the stoichiometric coefficients in equilibrium reaction q , rates for kinetic reaction k and equilibrium reaction q are denoting as r_k and r_q , numbers of kinetic and equilibrium reactions are n_k and n_q .

The phase equilibrium and composition limitations for gas-liquid phase thermodynamic equilibrium are expressed below:

$$f_{ag} - f_{al} = 0 \quad (4.5)$$

$$\sum_{a=1}^{n_f} X_{aj} - 1 = 0 \quad (4.6)$$

Where, f_{ag} and f_{al} are fugacity values of fluid species a in the gas and liquid phases. These fugacity values can be obtained using Henry's Law or the Peng-Robinson equation of state.

4.1.3 Geochemical Modeling

According to Nghiem et al. (2004) coupled system of equations that handles both flow and chemical reaction simulation are solved in two ways. These are sequential and simultaneous solution methods. The simultaneous method, also known as a fully coupled approach handles equations using Newton's method. This approach is used in order to model the fluid transport of reactive components in the aqueous phase. General Equation of State Model (GEMTM) provides adaptive-implicit multiphase multicomponent flow simulator that takes into account geochemical reactions based-on previously described fully coupled approach.

4.2.3.1 Intra-Aqueous Reactions

Nghiem et al. (2004) reported that reactions of the components within the aqueous phase can be expressed by the following stoichiometry:

$$\sum_{k=1}^{n_{aq}} V^a_{k\alpha} A_k = 0, \alpha = 1, \dots, R_{aq} \quad (4.7)$$

Where, R_{aq} is the number of reactions between aqueous species and A_k is the chemical symbol for the k -th aqueous component.

It is to bear in mind that mineral dissolution and precipitation reactions are slower than the reactions between the species taking place in the aqueous phase. Thus, latter ones can be expressed by chemical-equilibrium reactions, whereas former ones considered as a rate-dependent reaction.

As the chemical equilibrium reactions can be modelled with chemical equilibrium constants (Tanaka et al., 1995) the following equations considered as governing ones for the chemical equilibrium reaction:

$$Q_\alpha - K_{aq,\alpha} = 0, \alpha = 1, \dots, R_{aq} \quad (4.8)$$

$$Q_\alpha = \prod_{k=1}^{n_{aq}} a_k^{v_{k\alpha}} \quad (4.9)$$

4.1.3.2 Mineral Dissolution and Precipitation Reactions

The rate law for the mineral dissolution and precipitation reactions is expressed as follows (Koide et al., 1995):

$$r_\beta = \hat{A}_\beta k_\beta \left(1 - \frac{Q_\beta}{K_{eq,\beta}} \right), \beta = 1, \dots, R_{mn} \quad (4.10)$$

Where, r_β is the rate, \hat{A}_β is the reactive surface area for mineral β , k_β is the rate constant of mineral reaction β , $K_{eq,\beta}$ stands for the chemical equilibrium constant for mineral reaction β and Q_β is the activity product of mineral reaction β . The activity product Q_β is identical to the activity product for aqueous chemical equilibrium reactions.

4.1.4 Ion Exchange and Wettability Alteration Models

A critical condition to trigger the ion exchange mechanism is to inject water with different ion concentration than the formation brine. Modelling ion exchange phenomena is one of the crucial parameters to take into account during the simulation of low salinity waterflooding. The following reversible reactions are the most common ion exchange reactions:

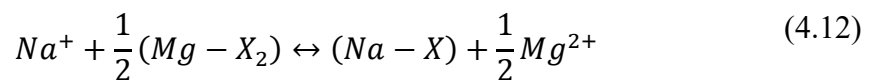
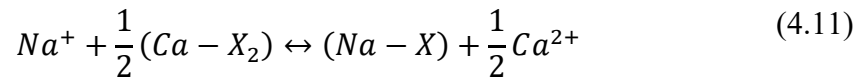

Where X stands to express clay mineral in the reservoir rock. Modelling ion exchange mechanisms requires introducing selectivity coefficients that are governed by Gaines-Thomas convention (Gained and Thomas, 1953):

$$K'_{\left(\frac{Na}{Ca}\right)} = \frac{\zeta(Na - X)[m(Ca^{2+})]^{0.5} [\gamma(Ca^{2+})]^{0.5}}{\zeta(Ca - X_2)[m(Na^+)] \gamma(Na^+)} \quad (4.13)$$

$$K'_{\left(\frac{Na}{Mg}\right)} = \frac{\zeta(Na - X)[m(Mg^{2+})]^{0.5} [\gamma(Mg^{2+})]^{0.5}}{\zeta(Mg - X_2)[m(Na^+)] \gamma(Na^+)} \quad (4.14)$$

Where equivalent fractions Na^+ , Ca^{2+} , Mg^{2+} on the exchangers are expressed as $\zeta(Na - X)$, $\zeta(Ca - X_2)$, $\zeta(Mg - X_2)$, m is molality, γ is an activity coefficient.

It is known that the consequence of low salinity effect is wettability alteration. A CMG GEM provides wettability alteration model based on the shift of relative permeability curves (Figure 4-2). A low salinity modeling package embedded in the compositional simulators offers relative permeability interpolation methods such as ion exchange, mineral volume fraction, and simple relative permeability interpolation of an aqueous phase component. The proposed mechanistic model utilizes ion exchange based relative permeability interpolation model. Traditionally, two set of relative permeability curves from both high salinity and low salinity waterfloods are needed to conduct the modelling. These data is taken from existing experimental work that included coreflooding study.

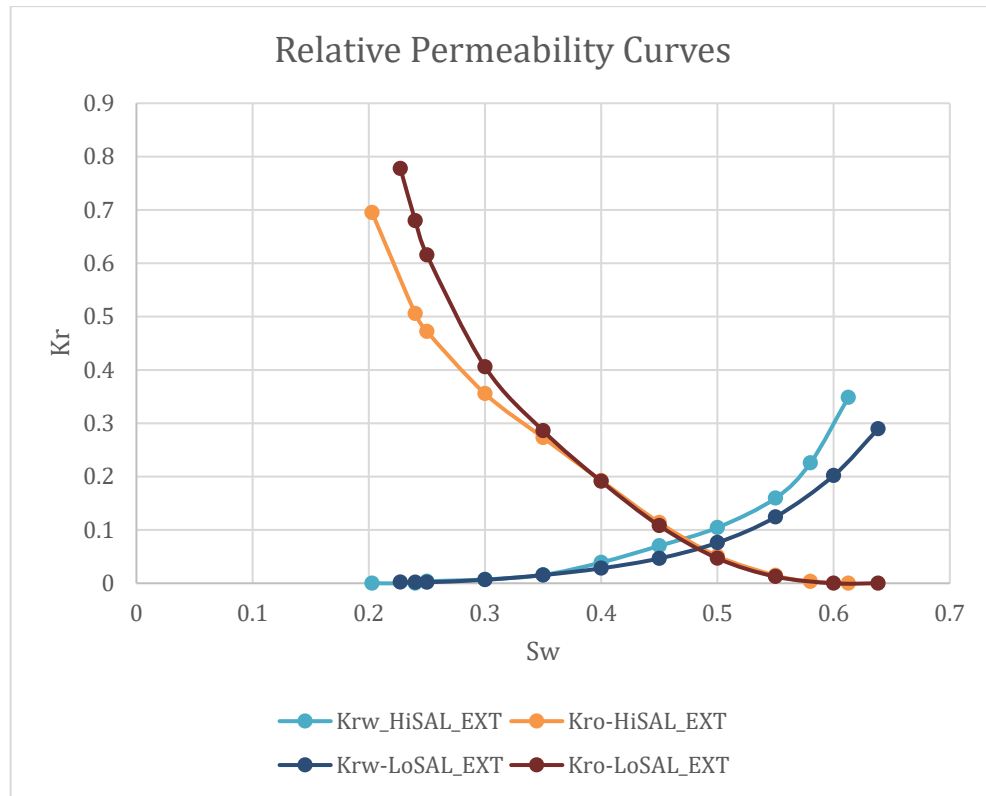

Figure 4-2. Relative permeability curves during high and low salinity waterflood

4.1.5 Modeling of CO₂ flooding

The WinProp software package, which is included in the CMG, allows modeling the behavior of fluids. Shortly, WinProp's scope includes EoS characterization, reservoir fluid characterization, miscibility prediction, and thermodynamic calculations. Miscibility prediction is based on the condensing, vaporizing, and condensing-vaporizing drives. Also, ternary diagrams can be generated in order to observe the graphical representation miscibility mechanisms. Methods such as cell to cell, multiple mixing cell, semi-analytical are used to determine the MMP and minimum miscibility enrichment (MME) values. During CO₂ flooding, carbon dioxide, besides swelling the oil phase, can also partition into the water phase. Thus, Henry's model is used to simulate the solubility of CO₂ gas in the water. On top of that, WinProp allows to account for the salinity of brine during the diffusion of the CO₂ gas.

4.2 Validation data

Shaddel et al. (2014) presented a set of corefloods on sandstone cores to study the impact of low salinity effect on relative permeability curves and wettability of the reservoir rock. The set of brine injections with seawater (SW) as high salinity water, ten times diluted formation water

(dFW0.1), and hundred times diluted sea formation (dFW0.01) as a low salinity water were performed separately in a secondary mode in order to observe the impact on the oil recovery, residual oil saturation, and relative permeability curves in sandstone cores. This experimental work contains sufficient data to generate a one-dimensional model designed to validate the proposed mechanistic model against laboratory results.

4.2.1. *Experimental Materials*

4.2.1.1 Cores

The core samples used during the experiments were taken from Iranian sandstone reservoir. The composition of cores looks as follows: quartz, clay, albite, and a minimum amount of calcite and dolomite. The core properties and mineralogy are presented in Table 4-1 and Table 4-2. Mineral composition of the core was defined by XRD (Moore, 1989) whereas porosity was acquired by weighing difference method (Amyx, 1960).

Table 4-1. The core properties (Shaddel et al., 2014)

Core ID	Length, cm	Diameter, cm	Porosity, %	Permeability, mD	S _{wi} (HS)	S _{wi} (LS)	Ageing Time, day
A2	4.94	3.8	14.6	20.9	0.221	0.207	30
A3	4.90	3.8	14.9	27.1	0.214	0.202	30
A4	4.91	3.8	15.8	23.7	0.212	0.205	30

Table 4-2. The mineral composition of cores (Shaddel et al., 2014)

Quartz	Albite	Kaolinite	Muscovite	Calcite	Dolomite
0.7	0.21	0.04	0.02	0.02	0.01

4.2.1.2 Crude oil

Two different oil types were used in these experiments. Oil sample A with the viscosity of 3.15 cp and acid number (AN) of 0.842 KOH/g. Oil sample B with the viscosity of 4.27 cp and acid number (AN) of 2.683 KOH/g. The information on oil samples is presented in the Table 4-3.

Table 4-3. Oil composition (Shaddel et al., 2014)

Oil Sample	Density, g/cc	Viscosity, cp	AN, KOH/g
A	0.855	3.15	0.842/0.21
B	0.920	4.27	2.683/0.39

4.2.1.2 Brine

The salts alike of reservoir formation brine were used in dissolving it in distilled water to prepare synthetic formation water (FW). Whereas seawater was utilized as high salinity water the pre-set dilutions of formation water such as ten times diluted formation brine, 100 times diluted formation brine. The summary of formation and sea waters is presented in Table 4-4.

Table 4-4. The injected brine composition (Shaddel et al., 2014)

Ion Components	Formation Water (ppm)	Sea Water (ppm)
Na ⁺	57332	11778
K ⁺	5872	985
Ca ²⁺	13600	382
Mg ²⁺	2673	1424
Cl ⁻	127436	22120
SO ₄ ²⁻	500	3118
Total Dissolved Salts	207413	39807

4.2.2. *Experimental Procedure*

Soxhlet apparatus was used to clean the core with toluene and methanol at 115°C. Afterwards, the core was dried at 60°C and then was saturated with the formation water with the objective of determining pore volume. Ionic equilibrium between the formation water and mineral surface was achieved by ageing the core with the formation water for 15 days at 70°C. After that core was aged for 30 days and mixed-wet wettability was established. The permeability value was measured by varying the flow rates in the core holder. As the first set of injection was done, the core was again cleaned by Soxhlet apparatus to check whether the same petrophysical values were obtained after the second set of low salinity water injection. The test oil was used in flooding until the irreducible water saturation of the core sample in order to get initial water saturation.

A typical core holder apparatus was used during the experimental study. Core holder had a confining pressure of 140 bar and a back pressure of 10 bar. The injection rate of 2 PV/day at 70°C as set during flooding sets. First, the core was flooded with the formation water then with the low salinity water. Fractional collector allowed to measure produced oil and define oil recovery factor. The effluent data and pH were recorded. A summary of experimental work is demonstrated in Table 4-5.

Table 4-5. Experimental results (Shaddel et al., 2014)

Exp. No.	Core ID	RF, %	LS Flood	RF, %	T, °C	Oil Type
1	A4	46.5	SW	50.8	70	B
2	A3	50	dFW0.1	54	70	B
3	A2	49	dFW0.01	56.7	70	B

5. RESULTS AND DISCUSSION

This chapter presents results and discussion that were drawn after the numerical study on the LSWAG. Firstly, the results on the validation of the one-dimensional model are demonstrated. The validation of the model implies comparison of simulation results with the existing experimental study in order to understand in what order the proposed model is representative and valid. Secondly, one-dimensional model was generated to see the impact of LSWAG on oil recovery in core dimensions. Thirdly, as the behavior of LSWAG was investigated in 1D model it is to extent it further to the sector model. The next sub-section exhibits the sthree dimensional simulation results of the LSWAG. Lastly, sensitivity analysis that includes investigation on the impact of operational parameters such as WAG ratio, cycling length, and start-up date is presented.

5.1 Validation of the model

5.1.1 *Description of One-Dimensional Model*

The CMG GEM compositional simulator was used to simulate the core flooding experiments A2, A3, A4 done by Shaddel et al. (2014). A one-dimensional model with the identical properties used in the experimental work included two vertical wells: injector and producer (Figure 5-1). The dimensions of the 1D model and the input data used for the generation of the model are presented in Tables 5-1 and 5-2. The case of low salinity water injection at 2 PV/Day ($1.632e-005 \text{ m}^3/\text{day}$) with the same composition as in laboratory study was used. All the geochemical reactions embedded in the model are shown in Table 5-3.

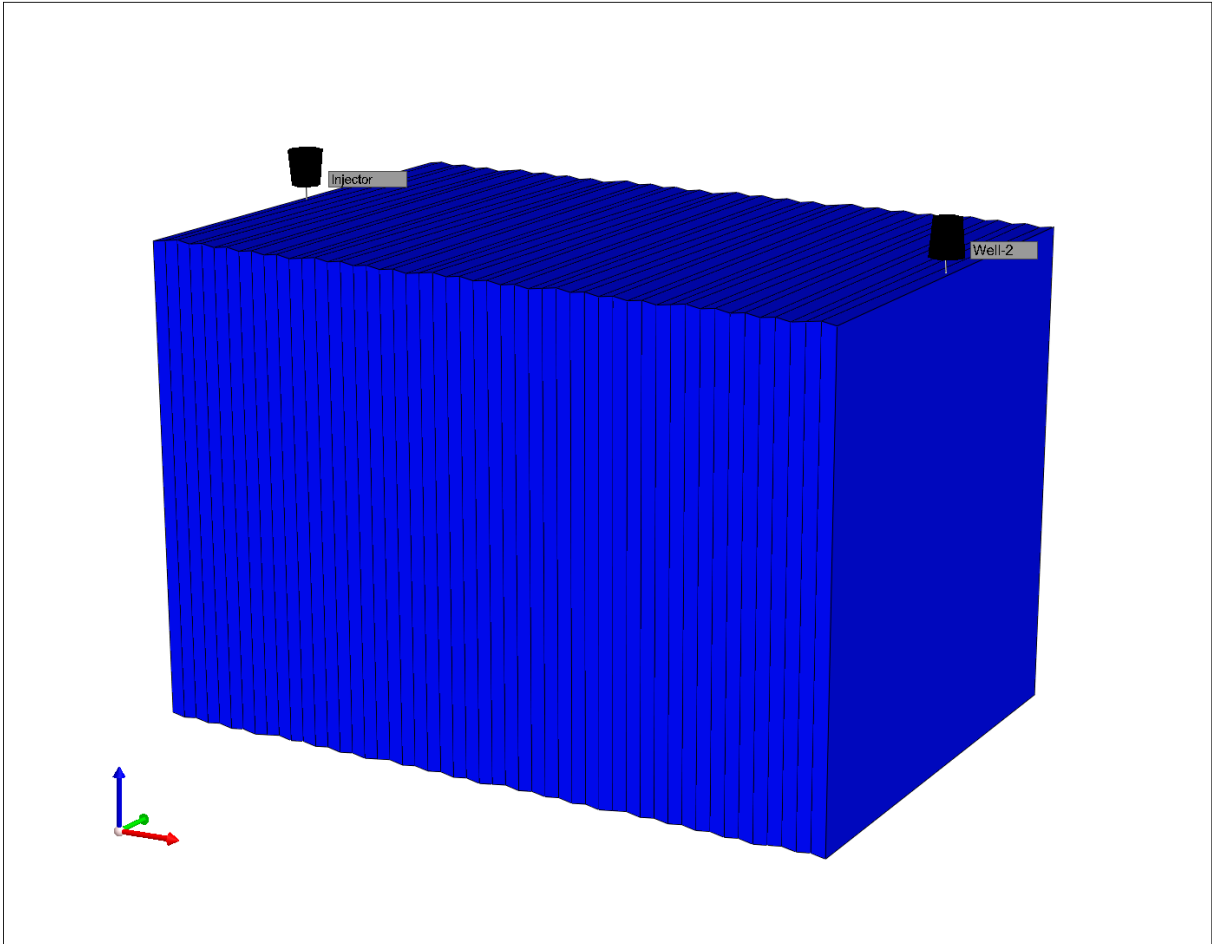

Figure 5-1. The view of one-dimensional model

Table 5-1. Dimensional specifications of one-dimensional model

Grid Dimension	50x1x1
Number of grids	50
X-direction grid size	0.000988 m
Y-direction grid size	0.03295 m
Z-direction grid size	0.03295 m

Table 5-2. Input data

Parameter	Value	Unit
Porosity	14.6-15.8	%
Permeability	20.9-23.7	mD

Pore Volume	$\approx 8e-006$	m^3
Temperature	70	C
Pressure	14000	kPA
Bottom Hole Pressure	12950	kPA
Perforation Size	0.002	m
Injection Rate	$1.632e-005$	m^3/day

Table 5-3. Geochemical reactions

Aqueous Reactions
$H^+ + (OH)^- \rightarrow H_2O$
$(CaHCO_3)^+ = Ca^{2+} + (HCO_3^-)$
$CaCO_3 + H^+ = Ca^{2+} + (HCO_3^-)$
$CaSO_4 = Ca^{2+} + SO_4^-$
$KCl = Cl^- + K^+$
$CO_2 + H_2O = H^+ + (HCO_3^-)$
Mineral/Solid Reactions
$Calcite(CaCO_3) + H^+ = Ca^{2+} + HCO_3^-$
$Magnesite(MgCO_3) + H^+ = HCO_3^- + Mg^{2+}$
$Ca(OH)_2(c) + 2(H^+) = Ca^{2+} + 2H_2O$

5.1.2 Validation Results

The Figures 5-2, 5-4, 5-6 exhibit the results of simulations compared to the original experimental data for each coreflooding test. The relative permeability curves (Figures 5-3, 5-5, 5-7) used in the model are digitized from the existing laboratory data. Based on the graphs (Figures 5-4, 5-6), it is clearly seen that simulations show consistent concordance with the physical studies. However, the figure 5-2 shows that there is a moderate level of mismatch between experimental and modeled values at the initial values of pore volume injected. Namely, it constitutes root mean square error of 8.37. In addition, one can observe that a decrease in the salinity of the injected water provided additional incremental oil recovery (Jadhunandan and Morrow (1995), Yildiz and Morrow (1996)). It is important to mention that reducing the salinity of the injected brine promoted the shift of relative permeability curves to more water-wet as it was found in a number of studies (Suijkerbuijk et al., 2012, Mugele et al., 2014).

5.1.2.1 Coreflooding Experiment A4 – Low salinity waterflood using SW

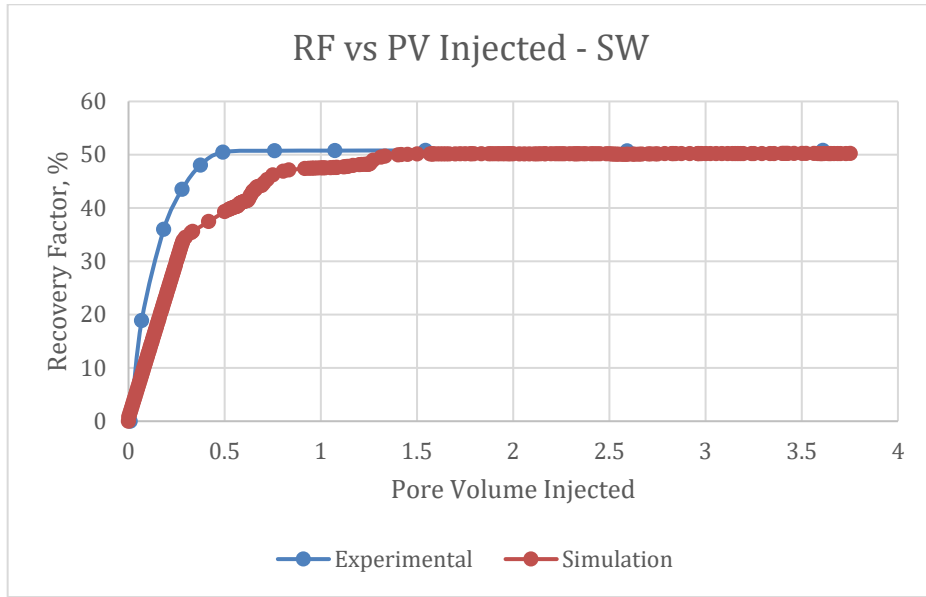

Figure 5-2. Validation of the low salinity water coreflood using SW

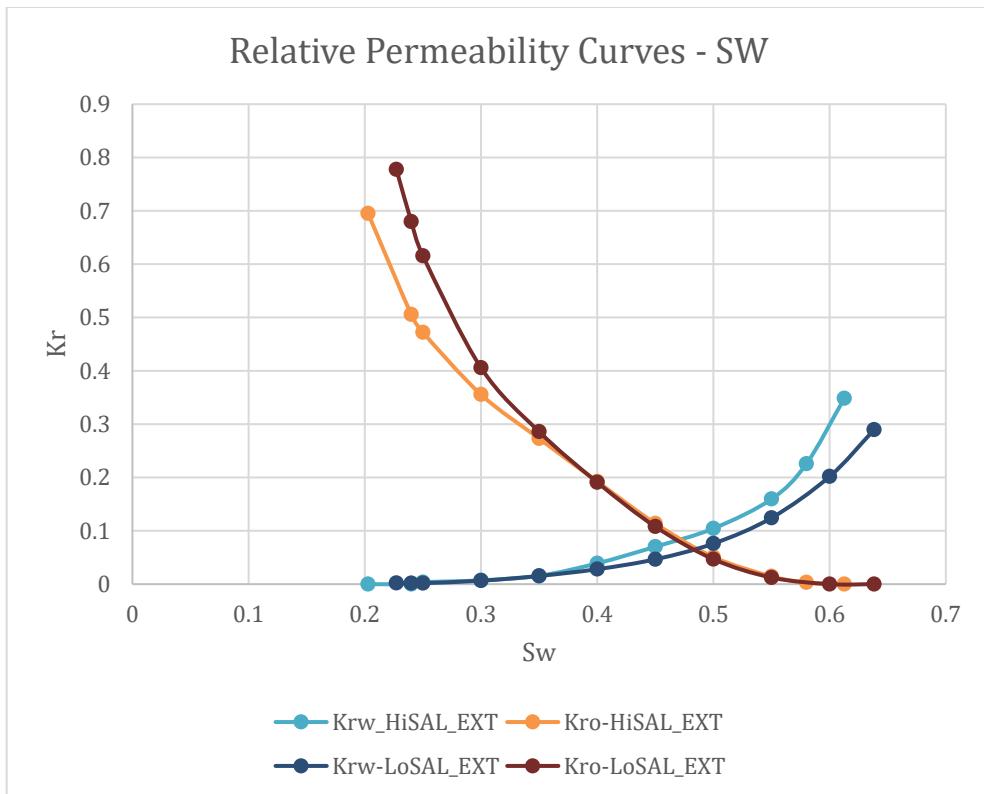

Figure 5-3. Relative permeability curves for A4 experiment (Shaddel et al. 2014)

5.1.2.2 Coreflooding Experiment A3 – Low salinity waterflood using dFW0.1

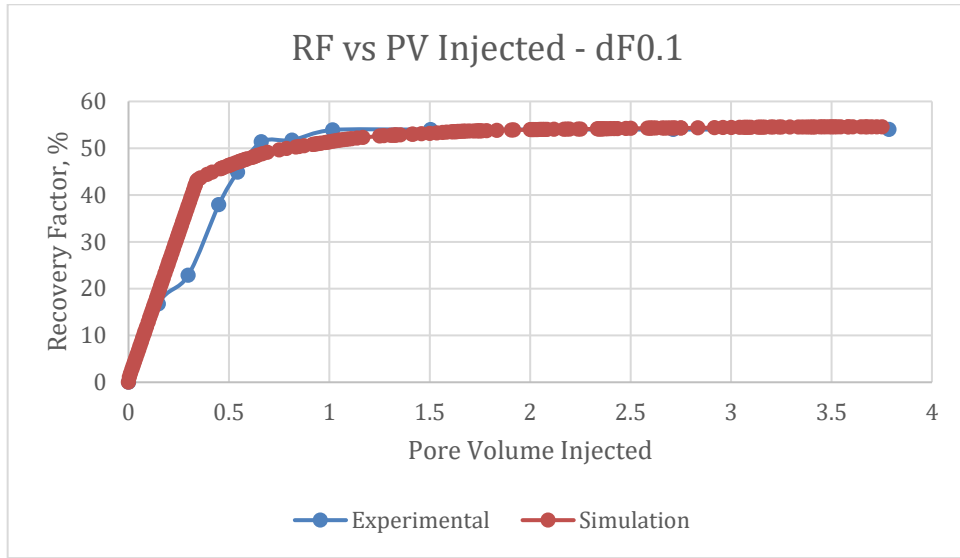

Figure 5-4. Validation of the low salinity water coreflood using dFW0.1

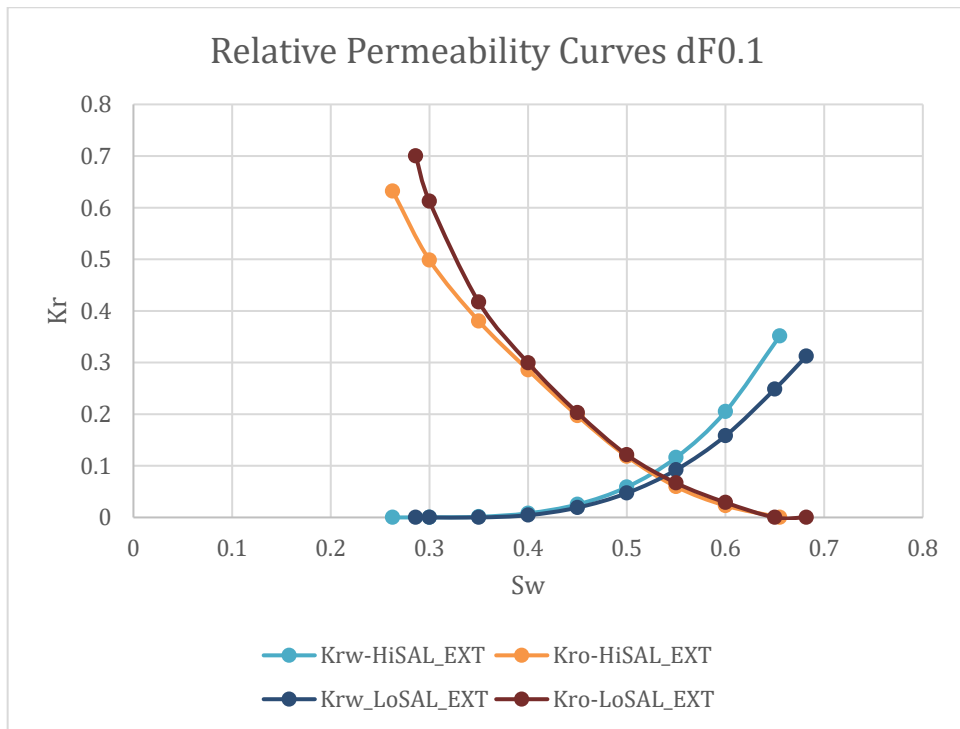

Figure 5-5. Relative permeability curves for A3 experiment (Shaddel et al. 2014)

5.1.2.3 Coreflooding Experiment A2 – Low salinity waterflood using dFW0.01

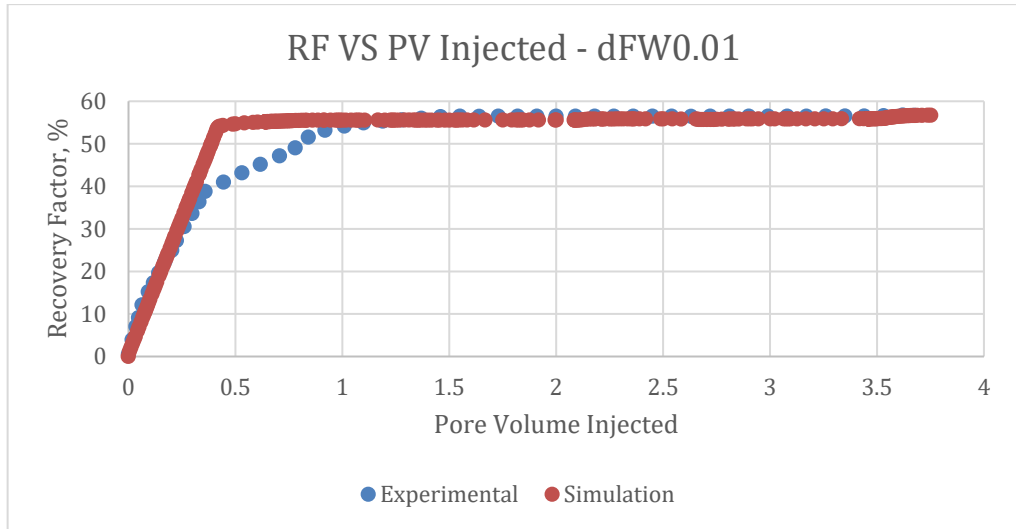

Figure 5-6. Validation of the low salinity water coreflood using dFW0.01

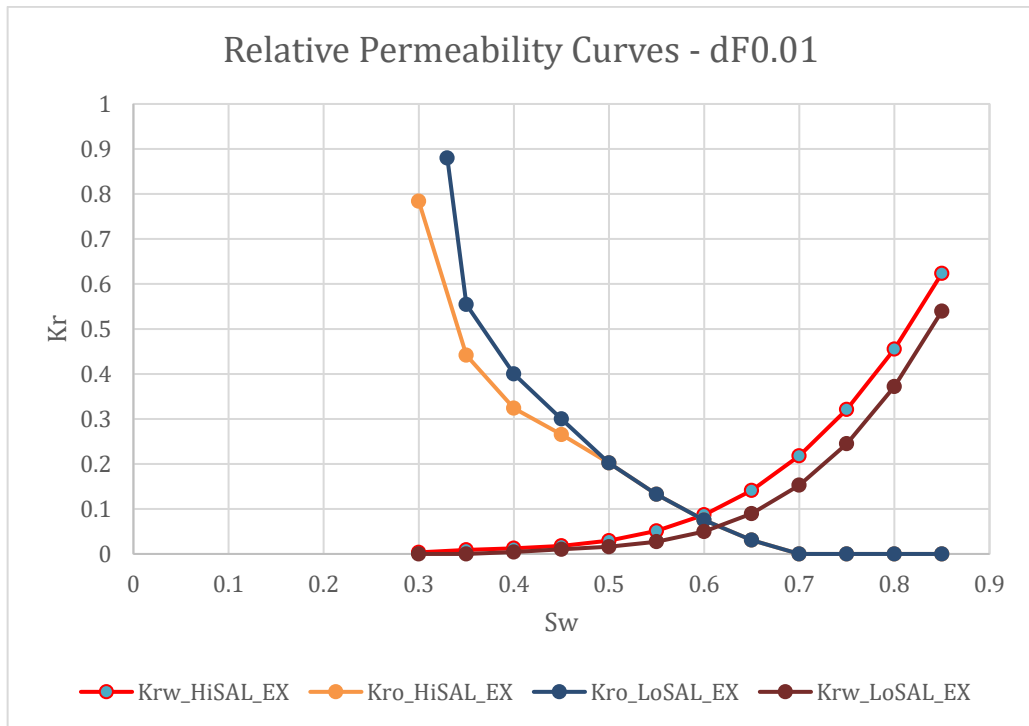

Figure 5-7. Relative permeability curves for A2 experiment (Shaddel et al. 2014)

5.2 One Dimensional Simulation of LSWAG

To see the impact of LSWAG on oil recovery, the validated one-dimensional homogenous model with the same grid specifications, geochemistry, and input values except for reservoir pressure and bottom hole pressure are utilized (65 and 64.75 MPa respectively). The flooding begins at the start of the oil production, and both LSWAG and WAG processes are miscible. It

is to note that water and gas injection wells are located on the same grid and have identical perforations (Figure 5-8). From now and on, seawater (SW) and 100 times diluted formation water (dFW0.01) addressed in Chapter 3 are denoted as high and low salinity water. The number of injection scenarios (Case 1 – high salinity waterflooding (SW) Case 2 – low salinity waterflooding (dFW0.01), Case 3 – high salinity water alternated CO₂ injection, and Case 4 – low salinity water alternated CO₂ injection) were set with the objective of comparing LSWAG with other conventional pressure maintenance and IOR technologies. Throughout the simulation, there were three cycles of WAG with the WAG ratio (ratio of water flow rate to gas flow rate) of 1:1 and period of 14 hours (Figure 5-11). Compositions of the injected brines can be found in Chapter 3.

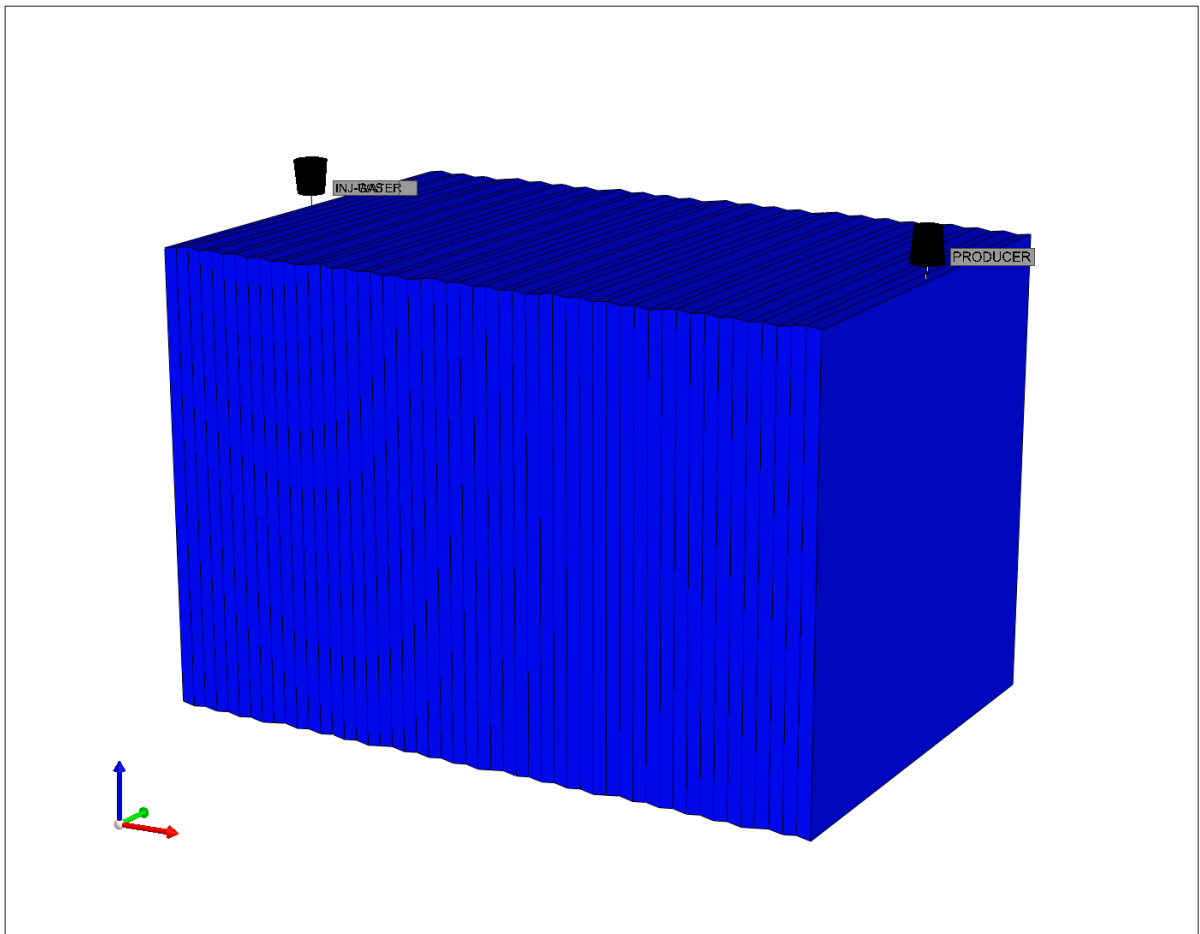

Figure 5-8. One-dimensional model of LSWAG

Comparison of Case 1 and Case 2 is presented in Figure 5-9. It is clearly noticeable that low salinity water injection outperforms high salinity water injection by approximately 7% in terms of recovery factor. This advantage is explained by the wettability alteration phenomena during injection of low salinity water that is addressed in Chapter 2.

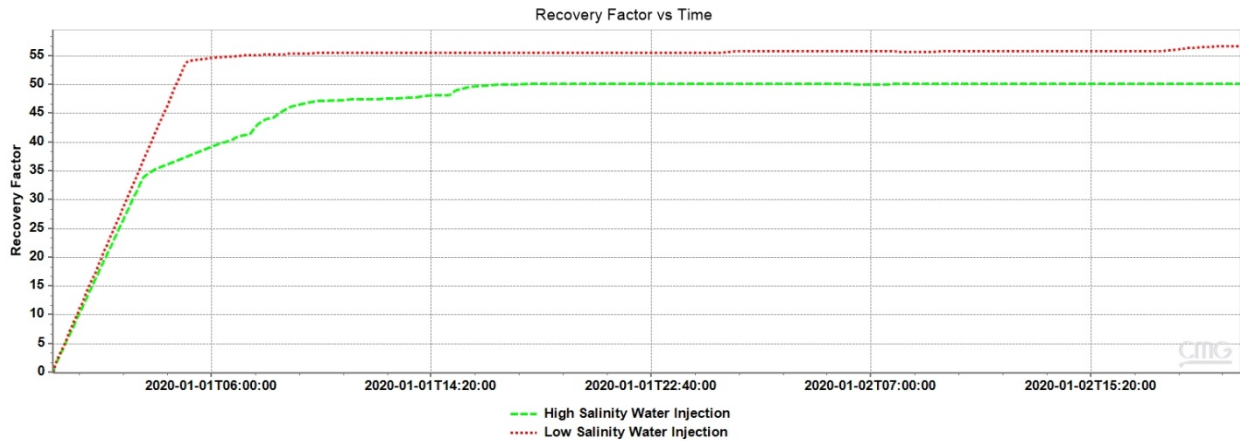

Figure 5-9. Comparison of Case 1 (HSW) and Case 2 (LSW)

As there is a need in order to achieve even more oil recovery, the alternated injection of water and CO₂ gas is introduced along with other injection modes (Figure 5-10). LSWAG leaves behind other cases with the recovery factor of 59%. The effect of LSWAG on oil recovery based on simulation results is consistent with the numerous laboratory studies (Aleidan et al., 2010; Zolfaghary, 2013; Teklu, 2016; Al-Quraishi et al., 2017; Al-Abri et al., 2018). In addition, results demonstrate concordance with other laboratory-scale simulations (Al-Shalabi et al. 2014; Dang et al. 2014; Naderi and Simjoo, 2019). The interesting thing is that HSWAG resulted in the lowest oil recovery value of 45.8%. Such number might be contradictory, but this is in line with the modelling study of Inaloo et al. (2014). Taking into account that the proposed model is homogenous, then the WAG should clearly perform better than the conventional waterflooding. Nevertheless, such kind of inconsistency might be because of the fact that WAG is commissioned at the start of the simulation date. Traditionally, WAG is considered as a tertiary oil recovery technique that is used to recover stagnant oil that was not extracted during primary and secondary stages of the oil recovery.

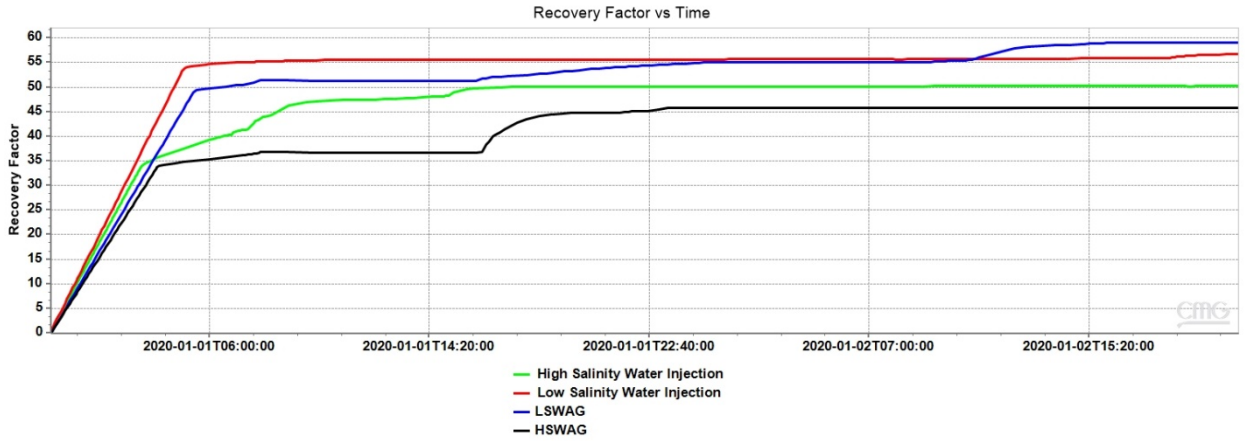

Figure 5-10. Case scenarios

Operational characteristics of the WAG plays crucial role in measuring the success of the implementation. These parameters include WAG ratio, WAG slug size, cycling duration, and the start of the WAG. The WAG ratio of 1:1 (Figure 5-11) is selected as it is considered as the most frequent ratio (Christensen et al. 2001).

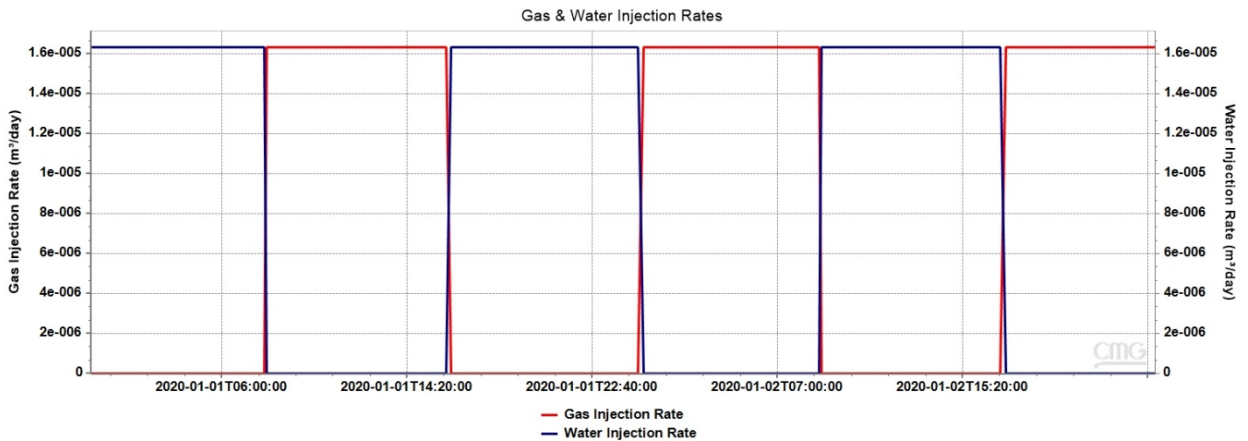

Figure 5-11. Ratio of WAG

5.3 Sector Model Simulation of LSWAG

As one-dimensional simulation showed that LSWAG surpassed other technologies in terms of oil recovery, there is a motivation to observe its potential to a larger extent. Thus, we propose a 3D heterogeneous model with the previous case scenarios (Figure 5-12). As an injection/production pattern, typical five-spot of four injection and one producer wells is utilized. The grid and operational specifications are shown in Table 5-4, and input parameters

except for porosity and absolute permeability values remain unchanged as one dimensional-model is scaled up to represent sector model characteristics. Compositions of the injected brines can be found in Chapter 3. The relative permeability curves for the injection of dF0.01 are deployed in this model.

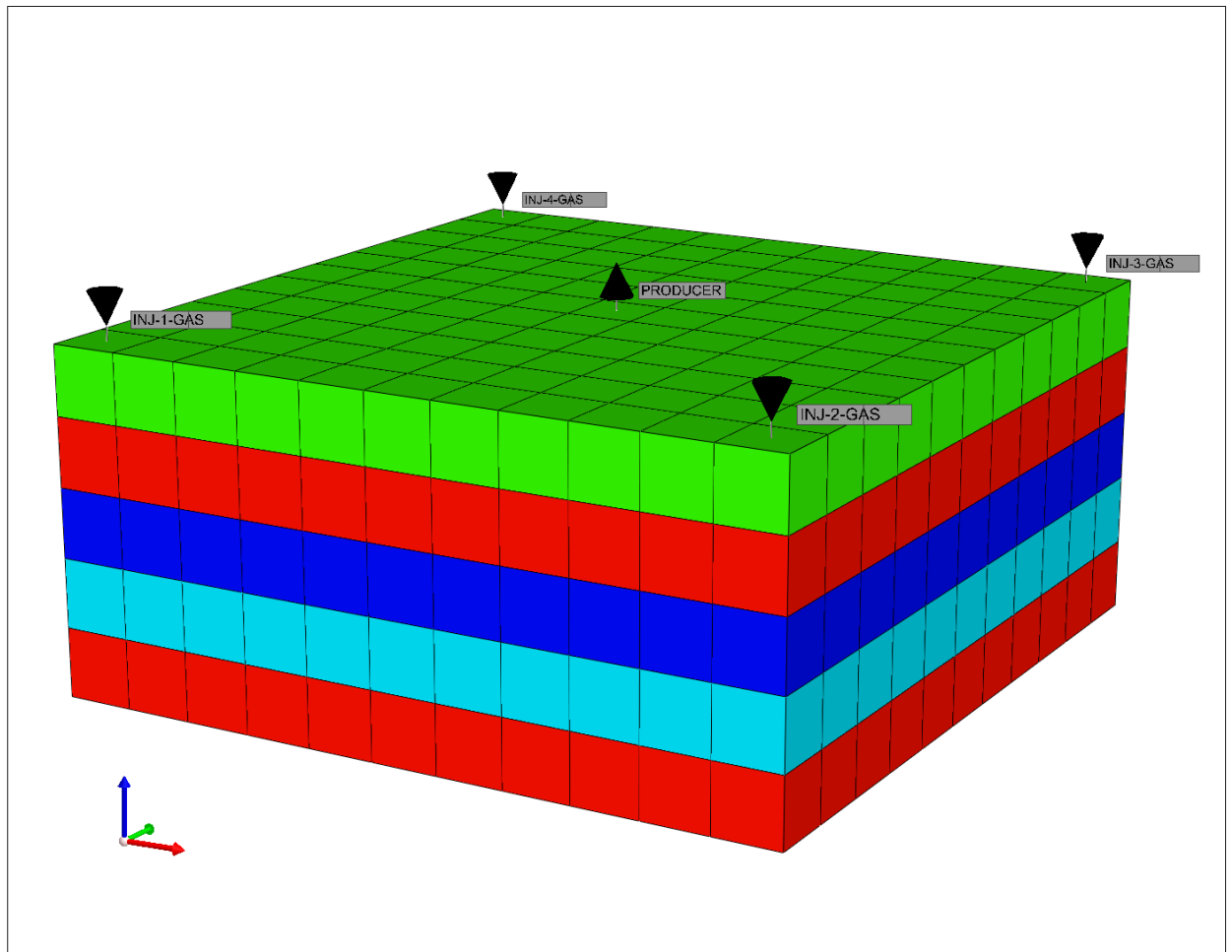

Figure 5-12. 3D view of heterogeneous sector model

Table 5-4. Dimensional, operational, and petrophysical specifications of the sector model

Grid Dimension	11x11x5
Number of grids	605
X-direction grid size	11*50 m
Y-direction grid size	11*50 m
Z-direction grid size	5*10 m

Water Injection Rate	600 m ³ /day
Gas Injection Rate	600 m ³ /day
Reservoir Pressure	65 MPa
Bottom Hole Pressure	64.75 MPa
Perforation radius	0.0762 m
Porosity	0.102-0.202
Permeability I-J-K	24-74 mD

Based on the simulation results it was revealed that use of LSWAG provided recovery of 57.2% of original oil in place (OOIP) which is higher than low salinity water injection for about 13.7% (Figure 5-13). This result aligns with the field-scale simulation in Norther Sea reservoir performed by Dang et al. (2014). The lowest recovery factor corresponds to both high salinity water injection and HSWAG constituting 38% of OOIP. Moreover, one should put attention to the level of water cut for all cases. It is seen from Figure 5-14 that the first rocketing of water-cut value is observed during high salinity waterflooding, whereas low salinity waterflooding shows the latest increase of water cut. However, the LSWAG demonstrates considerably low water cut and the latest breakthrough throughout the simulation period compared to the other scenarios.

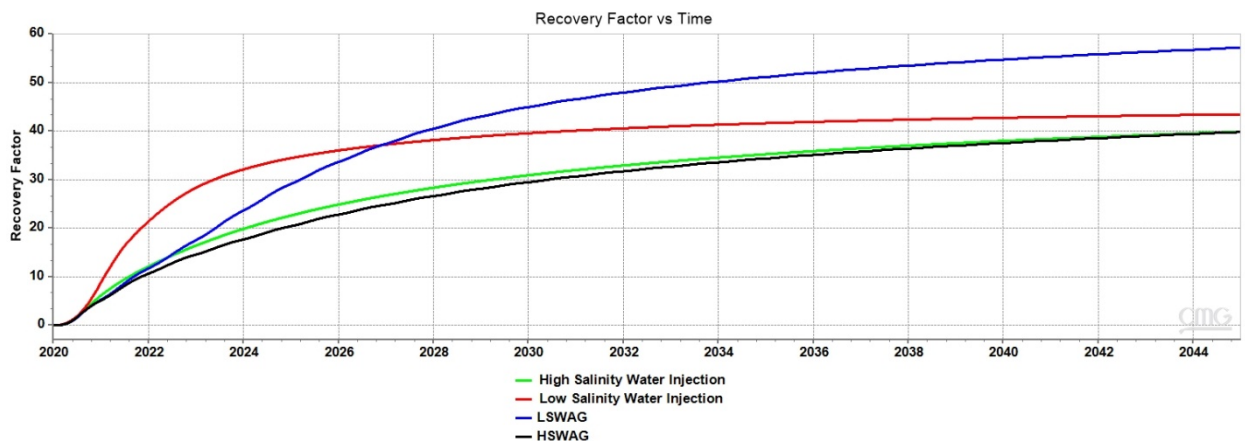

Figure 5-13. Oil recovery comparison for all cases

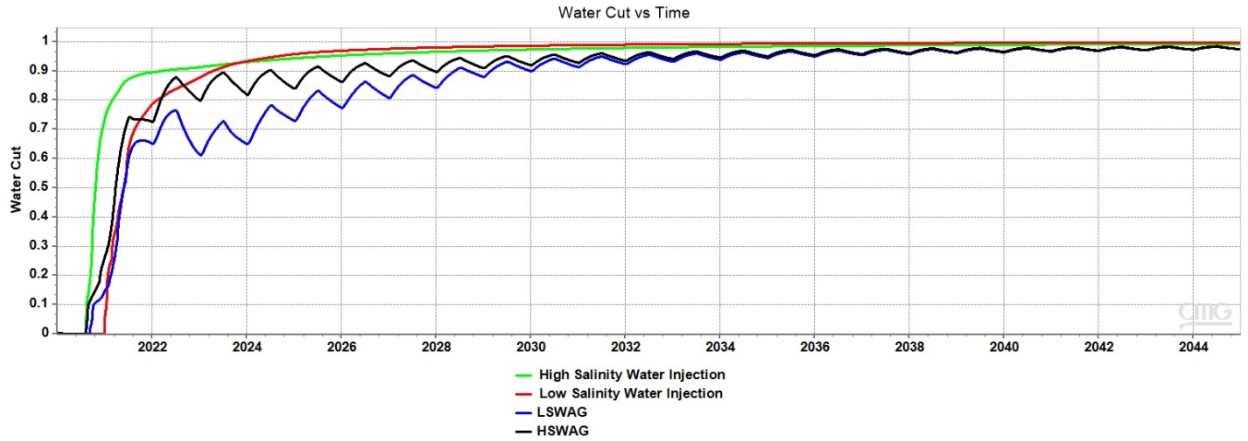

Figure 5-14. Water cut comparison for all cases

As it was previously mentioned, there are specific parameters that affect the performance of WAG. Chen et al. (2010) documented that WAG ratio plays a vital role in the design of WAG. The WAG ratio of 1:1 is chosen in the sector model simulation of LSWAG as Christensen et al. (2001) reported that the most regular field WAG ratio is 1:1 (Figure 5-15). However, further sections include a sensitivity study on oil recovery, including WAG ratio, WAG cycle length, and WAG kick-off date.

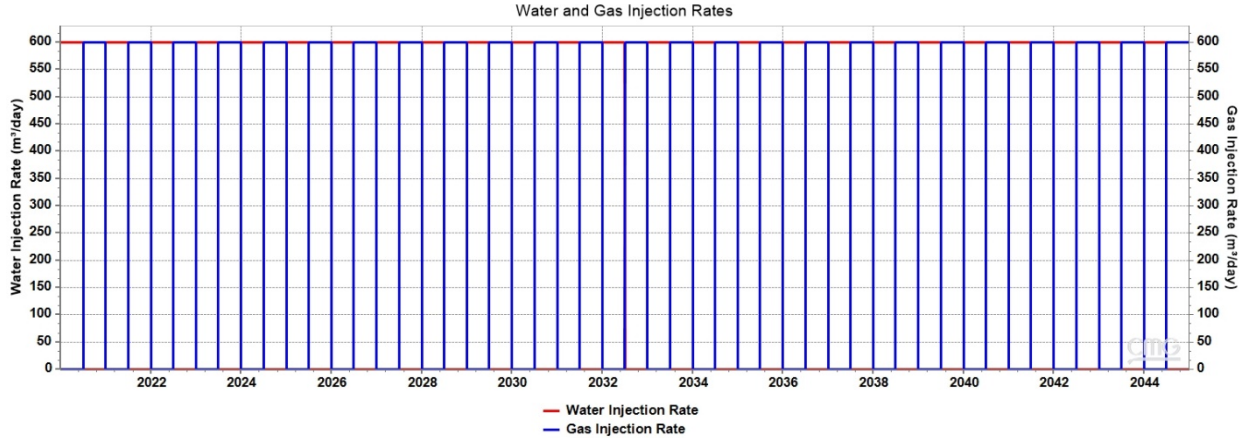

Figure 5-15. WAG ratio for both LSWAG and HSWAG

5.4 Sensitivity Analysis on LSWAG

To optimize the LSWAG technology, a sensitivity analysis, that includes a study on the operational characteristics such as ratio, cycling length, start-up date of WAG, is presented in this section.

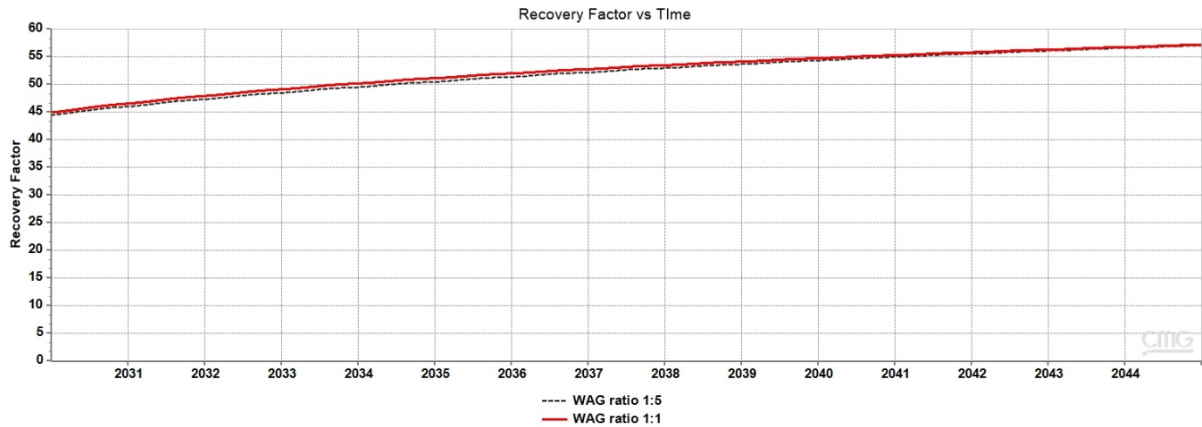

Figure 5-16. Sensitivity of recovery factor on WAG ratio

It is seen that there is an extremely small difference in terms of oil recovery between the WAG ratio of 1:1 and 1:5 (Figure 5-16). However, a lower ratio of WAG results in a higher oil recovery factor (Belazreg et al., 2019).

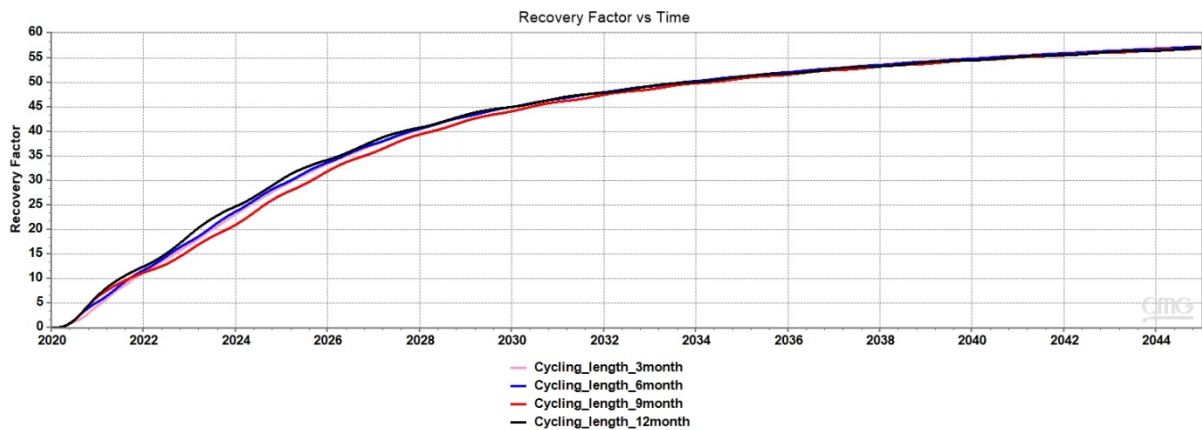

Figure 5-17. Sensitivity of recovery factor on length of cycling period

Figure 5-17 exhibit the various scenarios of WAG with cycling periods of 3, 6, 9, 12 months. Until the curves reach a plateau, it is possible to infer that cycling length of 12 months shows the highest oil recovery as opposed to the length of 9 months where recovery factor accounts for the lowest possible value among other cases. Wu et al. (2004) documented that the higher amount of OOIP is produced at shorter cycling lengths. Nonetheless, simulation results indicate that there is no such a relationship between oil recovery and WAG cycling length.

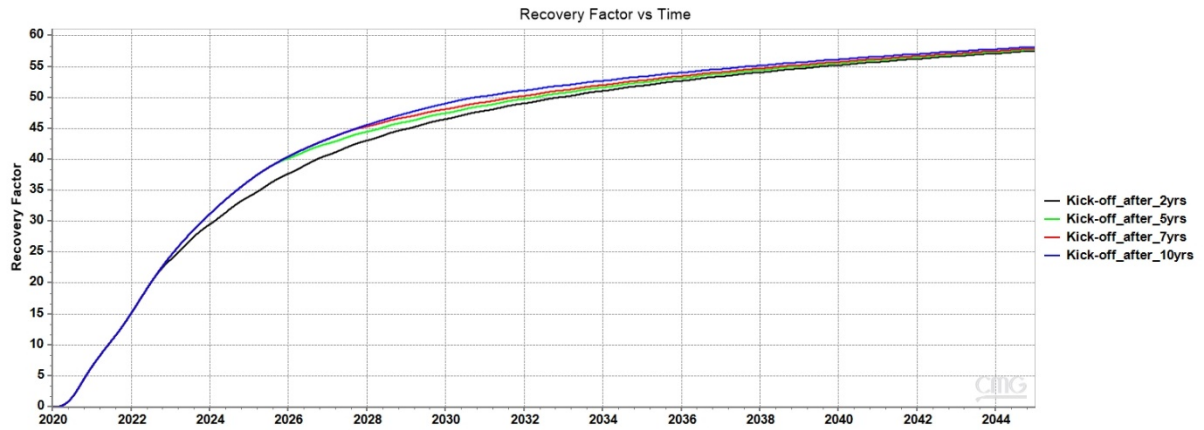

Figure 5-18. Sensitivity of recovery factor on start-up date of WAG

Figure 5-18 presents a sensitivity analysis based on alteration of kick-off time for LSWAG. All the cases imply injection of low salinity water for period of 2, 5, 7, 10 years consequently followed by LSWAG. It is plain that the later LSWAG is commissioned, the better oil recovery is observed. Namely, kick-off of LSWAG after 10 years of LSWF showed the highest recovery factor of 57.6%. The reason may lie in the fact that it is more convenient to fully leverage the benefit of low salinity waterflooding and only after that switch to alternating mode.

6. CONCLUSIONS AND RECOMMENDATIONS

In this research work, modeling and simulation study of LSWAG as a hybrid EOR method, has been performed using CMG software package in order to track the effect of proposed synergetic technology on oil recovery from sandstone reservoirs. The following 7 conclusions based on the results of this modelling and simulations study can be drawn:

1. Positive effect of LSWAG on oil recovery both in 1D and sector model dimensions was observed.
2. It demonstrated highest recovery factor of 59% and 57.2% on the coreflood and sector model scales.
3. The model is validated against 3 coreflooding experiments.
4. The impact of operational parameters such as WAG ratio, cycling length, start-up on recovery factor was investigated.
5. The results indicated that the WAG ratio of 1:1 provides higher oil recovery than the 1:5.
6. No relationship was found between the cycling length and recovery factor in this preliminary study.
7. Later kick-off of WAG allows to leverage the low salinity effect as it showed highest recovery of 57.6%.

From the simulation results, it is possible to infer that LSWAG triggered a considerable amount of incremental oil recovery compared to other EOR technologies. Nevertheless, to better understand the impact of LSWAG, the following recommendations are suggested for further study:

- Set of corefloods of LSWAG in both sandstones and carbonates
- Set of contact angle measurements to observe wettability alteration during LSWAG
- A laboratory study of assessing the solubility of CO₂ in low salinity water
- Full field-scale simulation of LSWAG

7. REFERENCES

- Al-Abri, H., Pourafshary, P., Mosavat, N., & Al Hadhrami, H., 2019. A study of the performance of the LSWA CO₂ EOR technique on improvement of oil recovery in sandstones. *Petroleum*, 5(1), 58-66.
- Aleidan, A. A., & Mamora, D. D., 2010. SWACO₂ and WACO₂ efficiency improvement in carbonate cores by lowering water salinity. In *Canadian Unconventional Resources and International Petroleum Conference*. Society of Petroleum Engineers.
- AlQuraishi, A. A., Amao, A. M., Al-Zahrani, N. I., AlQarni, M. T., & AlShamrani, S. A. , 2017. Low salinity water and CO₂ miscible flooding in Berea and Bentheimer sandstones. *Journal of King Saud University-Engineering Sciences*.
- Al-Shalabi, E. W., Sepehrnoori, K., Delshad, M., & Pope, G., 2015. A novel method to model low-salinity-water injection in carbonate oil reservoirs. *SPE Journal*, 20(05), 1-154.
- Amyx, J. W., Bass, D. M., & Whiting, R. L., 1960. Fundamental Properties of Fluid-Permeated Rocks. *Petroleum reservoir engineering: physical properties*, 1, 36-132.
- Andrianov, N., & Nick, H. M., 2019. Numerical simulation of low salinity waterflood on fractured chalk outcrop-based models. In *IOR 2019–20th European Symposium on Improved Oil Recovery* (Vol. 2019, No. 1, pp. 1-11). European Association of Geoscientists & Engineers.
- Arnarson, T. S., & Keil, R. G., 2000. Mechanisms of pore water organic matter adsorption to montmorillonite. *Marine chemistry*, 71(3-4), 309-320.
- Austad, T., Shariatpanahi, S. F., Strand, S., Black, C. J. J., & Webb, K. J., 2012. Conditions for a low-salinity enhanced oil recovery (EOR) effect in carbonate oil reservoirs. *Energy & fuels*, 26(1), 569-575.
- Awolayo, A. N., Sarma, H. K., & Nghiem, L. X., 2019. Numerical Modeling of Fluid-Rock Interactions during Low-Salinity-Brine-CO Flooding in Carbonate Reservoirs. In *SPE Reservoir Simulation Conference*. Society of Petroleum Engineers.
- Bartels, W. B., Mahani, H., Berg, S., & Hassanizadeh, S. M., 2019. Literature review of low salinity waterflooding from a length and time scale perspective. *Fuel*, 236, 338-353.

- Behrouz, T., Kharrat, R., & Ghazanfari, M. H., 2007. Experimental study of factors affecting heavy oil recovery in solvent floods. *In Canadian International Petroleum Conference*. Petroleum Society of Canada.
- Bernard, G. G., 1967. Effect of floodwater salinity on recovery of oil from cores containing clays. *In SPE California Regional Meeting*. Society of Petroleum Engineers.
- Bon, J., Sarma, H. K., & Theophilos, A. M., 2005. An investigation of minimum miscibility pressure for CO₂-rich injection gases with pentanes-plus fraction. *In SPE international improved oil recovery conference in Asia Pacific*. Society of Petroleum Engineers.
- Buckley, J. S., Takamura, K., & Morrow, N. R., 1989. Influence of electrical surface charges on the wetting properties of crude oils. *SPE Reservoir Engineering*, 4(03), 332-340.
- Carroll, J. J., Slupsky, J. D., & Mather, A. E., 1991. The solubility of carbon dioxide in water at low pressure. *Journal of Physical and Chemical Reference Data*, 20(6), 1201-1209.
- Caudle, B. H., & Dyes, A. B., 1958. Improving miscible displacement by gas-water injection. *Transactions of the AIME*, 213(01), 281-283.
- Chang, Y. B., Coats, B. K., & Nolen, J. S., 1996. A compositional model for CO₂ floods including CO₂ solubility in water. *In Permian Basin Oil and Gas Recovery Conference*. Society of Petroleum Engineers.
- Chavan, M., Dandekar, A., Patil, S., & Khataniar, S., 2019. Low-salinity-based enhanced oil recovery literature review and associated screening criteria. *Petroleum Science*, 1-17.
- Chen, S., Li, H., Yang, D., & Tontiwachwuthikul, P., 2010. Optimal parametric design for water-alternating-gas (WAG) process in a CO₂-miscible flooding reservoir. *Journal of canadian petroleum technology*, 49(10), 75-82.
- Cotterill, S., 2014. Low Salinity Effects on Oil Recovery. MSc Thesis. Imperial College London.
- Dandekar, A. Y., 2013. Petroleum reservoir rock and fluid properties. *CRC press*. ISBN 9781439876367. 132-139.
- Dang, C. T., Nghiem, L. X., Chen, Z., Nguyen, N. T., & Nguyen, Q. P., 2014. CO₂ low salinity water alternating gas: a new promising approach for enhanced oil recovery. *In SPE Improved Oil Recovery Symposium*. Society of Petroleum Engineers.

- Dang, C., Nghiem, L., Nguyen, N., Chen, Z., & Nguyen, Q., 2016. Mechanistic modeling of low salinity water flooding. *Journal of Petroleum Science and Engineering*, 146, 191-209.
- Derkani, M. H., Fletcher, A. J., Abdallah, W., Sauerer, B., Anderson, J., & Zhang, Z. J., 2018. Low salinity waterflooding in carbonate reservoirs: review of interfacial mechanisms. *Colloids and Interfaces*, 2(2), 20.
- Do, H. D., & Pinczewski, W. V., 1993. Diffusion-controlled swelling of reservoir oil by indirect contact with injection gas. *Chemical Engineering Science*, 48(18), 3243-3252.
- Duan, Z., & Sun, R., 2003. An improved model calculating CO₂ solubility in pure water and aqueous NaCl solutions from 273 to 533 K and from 0 to 2000 bar. *Chemical geology*, 193(3-4), 257-271.
- Duan, Z., Sun, R., Zhu, C., & Chou, I. M., 2006. An improved model for the calculation of CO₂ solubility in aqueous solutions containing Na⁺, K⁺, Ca²⁺, Mg²⁺, Cl⁻, and SO₄²⁻. *Marine Chemistry*, 98(2-4), 131-139.
- Ehrlich, R., & Wygal Jr, R. J., 1977. Interrelation of crude oil and rock properties with the recovery of oil by caustic waterflooding. *Society of Petroleum Engineers Journal*, 17(04), 263-270.
- Fathi, S. J., Austad, T., & Strand, S., 2010. "Smart water" as a wettability modifier in chalk: the effect of salinity and ionic composition. *Energy & fuels*, 24(4), 2514-2519.
- Fjelde, I., Asen, S. M., & Omekeh, A. V. 2012. Low salinity water flooding experiments and interpretation by simulations. *In SPE improved oil recovery symposium*. Society of Petroleum Engineers.
- Gaines Jr, G. L., & Thomas, H. C., 1953. Adsorption studies on clay minerals. II. A formulation of the thermodynamics of exchange adsorption. *The Journal of Chemical Physics*, 21(4), 714-718.
- Ghedan, S., 2009. Global laboratory experience of CO₂-EOR flooding. *In SPE/EAGE reservoir characterization & simulation conference* (pp. cp-170). European Association of Geoscientists & Engineers.
- Glossary, S. O., 2010. Schlumberger. Retrieved from the internet< URL: <http://glossary.connect.slb.com>> Terms: Primary Recovery.

- Green, D. W., & Willhite, G. P., 1998. Enhanced Oil Recovery, Vol. 6, 18-27. Richardson, Texas: *Textbook Series*, SPE.
- Grigg, R. B., & Schechter, D. S., 1997. State of the Industry in CO₂ Floods. *In SPE annual technical conference and exhibition*. Society of Petroleum Engineers.
- Hao, J., Mohammadkhani, S., Shahverdi, H., Esfahany, M. N., & Shapiro, A., 2019. Mechanisms of smart waterflooding in carbonate oil reservoirs-A review. *Journal of Petroleum Science and Engineering*.
- Hill, H. J., 1978. Cation Exchange in Chemical Flooding: Part 3-Experimental. *Society of Petroleum Engineers Journal*, 18(06), 445-456.
- Hilner, E., Andersson, M. P., Hassenkam, T., Matthiesen, J., Salino, P. A., & Stipp, S. L. S., 2015. The effect of ionic strength on oil adhesion in sandstone—the search for the low salinity mechanism. *Scientific reports*, 5(1), 1-9.
- Holm, L. W., 1986. Miscibility and miscible displacement. *Journal of Petroleum Technology*, 38(08), 817-818.
- Inaloo, M. B., Jafari, F., & Helalizadeh, A., 2014. Comparison of water flooding, gas injection and wagg injection scenarios performance in a five spot pattern. *World Applied Sciences Journal*, 31(1), 96-103.
- International Energy Agency (IEA)., 2006. World Energy Outlook 2006. Retrieved from <http://www.worldenergyoutlook.org/media/weowebiste/2008-1994/WEO2006.pdf>
- Israelachvili, J. N., 2015. Intermolecular and surface forces. *Academic press*.
- Jadhunandan, P. P., & Morrow, N. R., 1995. Effect of wettability on waterflood recovery for crude-oil/brine/rock systems. *SPE reservoir engineering*, 10(01), 40-46.
- Jarrell, P. M., Fox, C. E., Stein, M. H., & Webb, S. L., 2002. Practical aspects of CO₂ flooding (Vol. 22). Richardson, TX: Society of Petroleum Engineers.
- Jerauld, G. R., Webb, K. J., Lin, C. Y., & Secombe, J., 2006, January. Modeling low-salinity waterflooding. *In SPE Annual Technical Conference and Exhibition*. Society of Petroleum Engineers.

- Jiang, H., Nuryaningsih, L., & Adidharma, H., 2010. The effect of salinity of injection brine on water alternating gas performance in tertiary miscible carbon dioxide flooding: experimental study. *In SPE Western Regional Meeting*. Society of Petroleum Engineers.
- Kazemi Nia Korrani, A., Sepehrnoori, K., & Delshad, M., 2013. A novel mechanistic approach for modeling low salinity water injection. *In SPE Annual Technical Conference and Exhibition*. Society of Petroleum Engineers.
- King, M. B., Mubarak, A., Kim, J. D., & Bott, T. R., 1992. The mutual solubilities of water with supercritical and liquid carbon dioxides. *The Journal of Supercritical Fluids*, 5(4), 296-302.
- Knudsen, H. A., Aker, E., & Hansen, A., 2002. Bulk flow regimes and fractional flow in 2D porous media by numerical simulations. *Transport in Porous Media*, 47(1), 99-121.
- Korrani, A. K., & Jerauld, G. R., 2019. Modeling wettability change in sandstones and carbonates using a surface-complexation-based method. *Journal of Petroleum Science and Engineering*, 174, 1093-1112.
- Kozaki, C., 2012. Efficiency of low salinity polymer flooding in sandstone cores. Doctoral dissertation. The University of Texas at Austin.
- Lager, A., Webb, K. J., Black, C. J. J., Singleton, M., & Sorbie, K. S., 2008. Low salinity oil recovery-an experimental investigation1. *Petrophysics*, 49(01).
- Lake, L. W. (1989). Enhanced oil recovery. Englewood Cliffs, N.J: *Prentice Hall*.
- Lake, L. W., & Helfferich, F., 1978. Cation exchange in chemical flooding: Part 2 the effect of dispersion, cation exchange, and polymer/surfactant adsorption on chemical flood environment. *Society of Petroleum Engineers Journal*, 18(06), 435-444.
- Leverett, M.C., 1941. Capillary Behavior in Porous Solids. *Trans, AIME*, 142:152-69.
- Ligthelm, D. J., Gronsveld, J., Hofman, J., Brussee, N., Marcelis, F., & van der Linde, H. , 2009. Novel Waterflooding Strategy By Manipulation Of Injection Brine Composition. *In EUROPEC/EAGE conference and exhibition*. Society of Petroleum Engineers.
- Loahardjo, N., Xie, X., & Morrow, N. R., 2010. Oil recovery by sequential waterflooding of mixed-wet sandstone and limestone. *Energy & Fuels*, 24(9), 5073-5080.

- Mahani, H., Sorop, T., Ligthelm, D. J., Brooks, D., Vledder, P., Mozahem, F., & Ali, Y., 2011. Analysis of field responses to low-salinity waterflooding in secondary and tertiary mode in Syria. *In SPE Europec/EAGE Annual Conference and Exhibition*. Society of Petroleum Engineers.
- McGuire, P. L., Chatham, J. R., Paskvan, F. K., Sommer, D. M., & Carini, F. H., 2005. Low salinity oil recovery: An exciting new EOR opportunity for Alaska's North Slope. *In SPE western regional meeting*. Society of Petroleum Engineers.
- Moore, D. M., & Reynolds Jr, R. C., 1989. X-ray Diffraction and the Identification and Analysis of Clay Minerals. *Oxford University Press (OUP)*.
- Morrow, N. R., 1990. Wettability and its effect on oil recovery. *Journal of petroleum technology*, 42(12), 1-476.
- Morrow, N. R., Tang, G. Q., Valat, M., & Xie, X., 1998. Prospects of improved oil recovery related to wettability and brine composition. *Journal of Petroleum science and Engineering*, 20(3-4), 267-276.
- Mugele, F., Siretanu, I., Kumar, N., Bera, B., Wang, L., Maestro, A., & Collins, I., 2014. Charge Control and Wettability Alteration at Solid-liquid Interfaces. *In SPE Improved Oil Recovery Symposium*. Society of Petroleum Engineers.
- Muskat, M., 1949. Physical principles of oil production: *McGraw-Hill Book Company, Inc.*, New York.
- Myint, P. C., & Firoozabadi, A., 2015. Thin liquid films in improved oil recovery from low-salinity brine. *Current Opinion in Colloid & Interface Science*, 20(2), 105-114.
- Naderi, S., & Simjoo, M., 2019. Numerical study of Low Salinity Water Alternating CO₂ injection for enhancing oil recovery in a sandstone reservoir: Coupled geochemical and fluid flow modeling. *Journal of Petroleum Science and Engineering*, 173, 279-286.
- Nghiem, L. X., 1989. A unified and flexible approach for handling and solving large systems of equations in reservoir simulation. *In Proceedings for First and Second International Forum on Reservoir Simulation*, 1989 (pp. 501-550). Paul Steiner Publishing Co..
- Nghiem, L. X., Shrivastava, V. K., & Kohse, B. F., 2011. Modeling aqueous phase behavior and chemical reactions in compositional simulation. *In SPE reservoir simulation symposium*. Society of Petroleum Engineers.

Nghiem, L. X., Yang, C., Shrivastava, V. K., Kohse, B. F., Hassam, M. S., Chen, D., & Card, C., 2009. Optimization of residual gas and solubility trapping for CO₂ sequestration in saline aquifers. *In SPE Reservoir Simulation Symposium. Society of Petroleum Engineers.*

Nghiem, L., Sammon, P., Grabenstetter, J., & Ohkuma, H., 2004. Modeling CO₂ storage in aquifers with a fully-coupled geochemical EOS compositional simulator. *In SPE/DOE symposium on improved oil recovery.* Society of Petroleum Engineers.

Nghiemw, L., Shrivastavar, A., Kohse, B., & Sammon, P., 2004. Simulation of CO₂ EOR and Sequestration Processes With a Geochemical EOS Compositional Simulator. *In Canadian International Petroleum Conference.* Petroleum Society of Canada.

Obeida, T. A., Kalam, M. Z., Al-Sahn, H., Gibson, A. P., Mesalmeh, S., & Zhang, H., 2010. Laboratory Studies at Reservoir Conditions on the Impact of Acid Gas and CO₂ Displacements on the Carbonate Matrix. *In Abu Dhabi International Petroleum Exhibition and Conference.* Society of Petroleum Engineers.

Omekeh, A. V., Friis, H. A., Fjelde, I., & Evje, S., 2012. Modeling of ion-exchange and solubility in low salinity water flooding. *In SPE improved oil recovery symposium.* Society of Petroleum Engineers.

Parkhurst, D. L., & Wissmeier, L., 2015. PhreeqcRM: A reaction module for transport simulators based on the geochemical model PHREEQC. *Advances in Water Resources*, 83, 176-189.

Patil, S. B., Dandekar, A. Y., Patil, S., & Khataniar, S., 2008. Low salinity brine injection for EOR on Alaska North Slope (ANS). *In International Petroleum Technology Conference.* International Petroleum Technology Conference.

Perera, M. S. A., Gamage, R. P., Rathnaweera, T. D., Ranathunga, A. S., Koay, A., & Choi, X., 2016. A review of CO₂-enhanced oil recovery with a simulated sensitivity analysis. *Energies*, 9(7), 481.

Pope, G. A., Lake, L. W., & Helfferich, F. G., 1978. Cation exchange in chemical flooding: Part 1 basic theory without dispersion. *Society of Petroleum Engineers Journal*, 18(06), 418-434.

- Portier, S., & Rochelle, C., 2005. Modelling CO₂ solubility in pure water and NaCl-type waters from 0 to 300 C and from 1 to 300 bar: Application to the Utsira Formation at Sleipner. *Chemical Geology*, 217(3-4), 187-199.
- Qiao, C., Johns, R., & Li, L., 2016. Modeling low-salinity waterflooding in chalk and limestone reservoirs. *Energy & Fuels*, 30(2), 884-895.
- Qiao, C., Johns, R., Li, L., & Xu, J., 2015. Modeling low salinity waterflooding in mineralogically different carbonates. In *SPE annual technical conference and exhibition*. Society of Petroleum Engineers.
- Rackley, S. A., 2017. Carbon capture and storage. *Butterworth-Heinemann*.
- Reiter, P. K., 1961. A water-sensitive sandstone flood using low salinity water. Doctoral dissertation. University of Oklahoma.
- Rivet, S., 2009. MS Thesis: Coreflooding Oil Displacements with Low Salinity Brine. The University of Texas: Austin, Texas.
- Robertson, E. P., 2010. Oil recovery increases by low-salinity flooding: Minnelusa and Green River formations (No. INL/CON-10-18262). *Idaho National Laboratory (INL)*.
- Schlumberger. 2007. Schlumberger Market Analysis. Retrieved from http://www.slb.com/~-/media/Files/industry_challenges/carbonates/brochures/cb_carbonate_reservoirs_07os003.ashx
- Shaddel, S., Tabatabae-Nejad, S. A., & Fathi, S. J., 2014. Low-salinity water flooding: Evaluating the effect of salinity on oil and water relative permeability, wettability, and oil recovery. *Special Topics & Reviews in Porous Media: An International Journal*, 5(2).
- Shehata, A. M., Alotaibi, M. B., & Nasr-El-Din, H. A., 2014. Waterflooding in carbonate reservoirs: Does the salinity matter?. *SPE Reservoir Evaluation & Engineering*, 17(03), 304-313.
- Sheng, J.J., 2014. Critical review of low-salinity waterflooding. *Journal of Petroleum Science and Engineering*, 120, pp.216-224.
- Skrettingland, K., Holt, T., Tweheyo, M. T., & Skjevrak, I., 2011. Snorre Low-Salinity-Water Injection Coreflooding Experiments and Single-Well Field Pilot. *SPE Reservoir Evaluation & Engineering*, 14(02), 182-192.

- Sorbie, K. S., & Collins, I., 2010. A proposed pore-scale mechanism for how low salinity waterflooding works. *In SPE improved oil recovery symposium*. Society of Petroleum Engineers.
- Sposito, G., 1989. *The Chemistry of Soils*. Oxford Univ. Press, New York, USA, 255.
- Stalkup, F. I., 1970. Displacement of oil by solvent at high water saturation. *Society of Petroleum Engineers Journal*, 10(04), 337-348.
- Steeffel, C. I., & MacQuarrie, K. T., 1996. Approaches to modeling of reactive transport in porous media. *Reviews in Mineralogy and Geochemistry*, 34(1), 85-129.
- Suijkerbuijk, B., Hofman, J., Ligthelm, D. J., Romanuka, J., Brussee, N., van der Linde, H., & Marcelis, F., 2012. Fundamental investigations into wettability and low salinity flooding by parameter isolation. *In SPE Improved Oil Recovery Symposium*. Society of Petroleum Engineers.
- Tang, G. Q., & Morrow, N. R., 1997. Salinity, temperature, oil composition, and oil recovery by waterflooding. *SPE Reservoir Engineering*, 12(04), 269-276.
- Tang, G. Q., & Morrow, N. R., 1999. Influence of brine composition and fines migration on crude oil/brine/rock interactions and oil recovery. *Journal of Petroleum Science and Engineering*, 24(2-4), 99-111.
- Tang, G. Q., & Morrow, N. R., 1999. Oil recovery by waterflooding and imbibition invading brine cation valency and salinity. *Paper SCA9911*.
- Teklu, T. W., Alameri, W., Graves, R. M., Kazemi, H., & AlSumaiti, A. M., 2016. Low-salinity water-alternating-CO₂ EOR. *Journal of Petroleum Science and Engineering*, 142, 101-118.
- Thibeau, S., Nghiem, L. X., & Ohkuma, H., 2007. A modelling study of the role of selected minerals in enhancing CO₂ mineralization during CO₂ aquifer storage. *In SPE Annual Technical Conference and Exhibition*. Society of Petroleum Engineers.
- Thyne, G. D., Gamage, S., & Hasanka, P., 2011. Evaluation of the effect of low salinity waterflooding for 26 fields in Wyoming. *In SPE Annual Technical Conference and Exhibition*. Society of Petroleum Engineers.

- Valocchi, A. J., Street, R. L., & Roberts, P. V., 1981. Transport of ion-exchanging solutes in groundwater: Chromatographic theory and field simulation. *Water Resources Research*, 17(5), 1517-1527.
- Vledder, P., Gonzalez, I. E., Carrera Fonseca, J. C., Wells, T., & Ligthelm, D. J., 2010. Low salinity water flooding: proof of wettability alteration on a field wide scale. *In SPE Improved Oil Recovery Symposium*. Society of Petroleum Engineers.
- Wang, L., & Fu, X., 2018. Data-driven analyses of low salinity water flooding in sandstones. *Fuel*, 234, 674-686.
- Webb, K. J., Black, C. J. J., & Al-Ajeel, H., 2003. Low salinity oil recovery-log-inject-log. *In Middle East Oil Show*. Society of Petroleum Engineers.
- Welge, J.H., 1952. A Simplified Method for Computing Oil Recoveries by Gas or Water Drive. *Trans, AIME*, 1952, 195:91-98.
- Wilmott, Z. M., Breward, C. J. W., & Chapman, S. J., 2020. A dynamic network model for the action of low salinity on two-phase flow. *Advances in Water Resources*, 137, 103520.
- Wu, X., Ogbe, D. O., Zhu, T., & Khataniar, S., 2004. Critical design factors and evaluation of recovery performance of miscible displacement and WAG process. *In Canadian International Petroleum Conference*. Petroleum Society of Canada.
- Wu, Y. S., & Bai, B., 2009. Efficient simulation for low salinity waterflooding in porous and fractured reservoirs. *In SPE Reservoir Simulation Symposium*. Society of Petroleum Engineers.
- Xie, Q., Saeedi, A., Pooryousefy, E., & Liu, Y., 2016. Extended DLVO-based estimates of surface force in low salinity water flooding. *Journal of Molecular Liquids*, 221, 658-665.
- Yousef, A. A., Al-Saleh, S., Al-Kaabi, A. U., & Al-Jawfi, M. S., 2010. Laboratory investigation of novel oil recovery method for carbonate reservoirs. *In Canadian Unconventional Resources and International Petroleum Conference*. Society of Petroleum Engineers.
- Zhang, P., & Austad, T., 2006. Wettability and oil recovery from carbonates: Effects of temperature and potential determining ions. *Colloids and Surfaces A: Physicochemical and Engineering Aspects*, 279(1-3), 179-187.

Zhang, Y., & Morrow, N. R., 2006. Comparison of secondary and tertiary recovery with change in injection brine composition for crude-oil/sandstone combinations. *In SPE/DOE symposium on improved oil recovery*. Society of Petroleum Engineers.

Zolfaghari, H., Zebarjadi, A., Shahrokhi, O., & Ghazanfari, M. H., 2013. An experimental study of CO₂-low salinity water alternating gas injection in sandstone heavy oil reservoirs. *Iranian Journal of Oil & Gas Science and Technology*, 2(3), 37-47.