

PV self-consumption with heat pump systems: Optimizing systems with electrical and thermal storage by use of simulation

Hanna Sotnikova, June 15, 2017

sotn@zhaw.ch

Contents

- Introduction
- Simulation algorithms
- PV self-consumption
- Control strategies in Polysun
- SMA Sunny Design tool
- Conclusion

Introduction

- Company Vela Solaris
 - Spin-Off in 2006 from SPF Institute of Solar Technology, Rapperswil
 - Modern software development
 - professional support
 - Company versions
 - Distribution all over the world (>50% export)
- Research projects
 - Innovation projects with Universities of applied sciences, ETH Zurich und Universities in the EU
 - Close partnership with ZHAW since 2016



Bundesamt für Energie BFE
Swiss Federal Office of Energy SFOE



swiss made
software

Polysun: PV as a part of energy system

polysun[®]
SIMULATION SOFTWARE

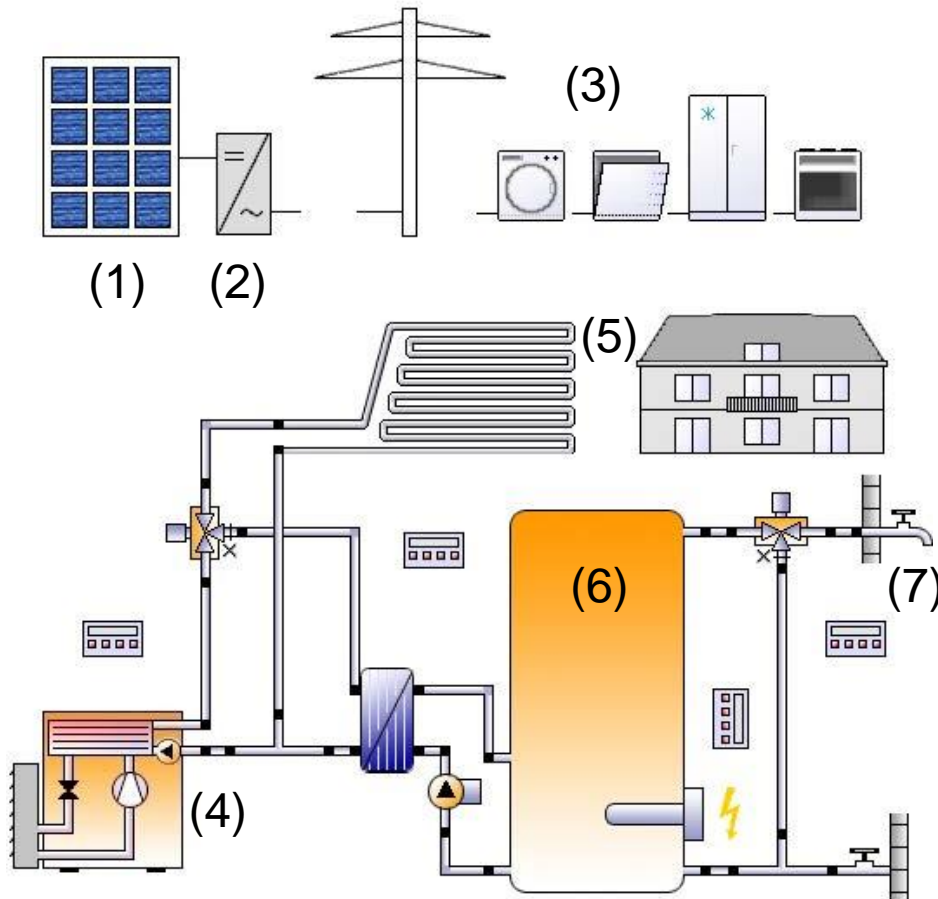

(1) PV-field

(2) Inverter

(3) Electrical consumption profile

(4) Heat pump

(5) Floor heating

(6) Storage tank

(7) Hot water tap

«Normal PV-System» → Polysun Wizard

Suchen nach

Suchergebnisse

L...	Postle...	Ortsname	Breit...	Län...
CH	8400	Winterthur	47.4...	8.72...
CH	8401	Winterthur	47.5	8.75
CH	8404	Winterthur	47.5...	8.75...
CH	8405	Winterthur	47.4...	8.77...
CH	8406	Winterthur	47.4...	8.70...
CH	8408	Winterthur	47.5...	8.68...
CH	8411	Winterthur	47.5	8.75
CH	8402	Winterthur	47.5	8.75
CH	8409	Winterthur	47.5...	8.78...
CH	8410	Winterthur	47.5	8.75
CH	8404	Stadel (Winterthur)	47.5...	8.76...
US	19735	Winterthur	39.7...	-75...
CH	8404	Reutlingen (Winterthur)	47.5...	8.75...
CH	8482	Sennhof (Winterthur)	47.4...	8.75...
CH	8353	Elgg	47.4...	8.86...
CH	8413	Nefenbach	47.5...	8.66...
CH	8422	Pfungen	47.5...	8.64...
CH	8442	Hettlingen	47.5...	8.71...
CH	8472	Seuzach	47.5...	8.72...
CH	8488	Turbenthal	47.4...	8.87...
CH	8542	Wiesendangen	47.5...	8.78...
CH	8311	Brütten	47.4...	8.67...
CH	8474	Dinhard	47.5...	8.76...

Lat=47.497; Lon=8.73; Alt=446; TZ=1

Weather data from
Meteonorm
www.meteonorm.ch
www.meteotest.ch

Shading losses

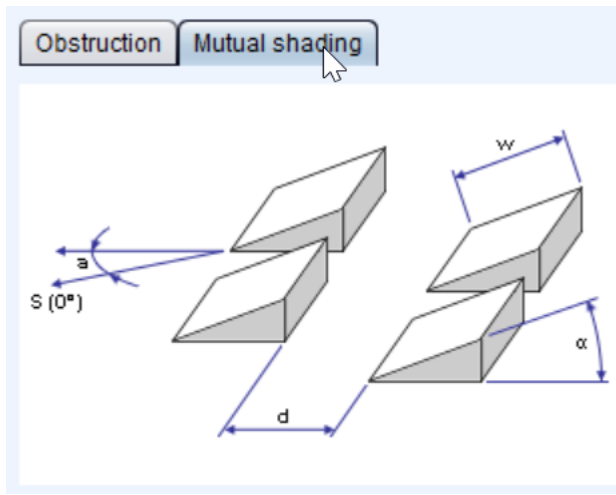
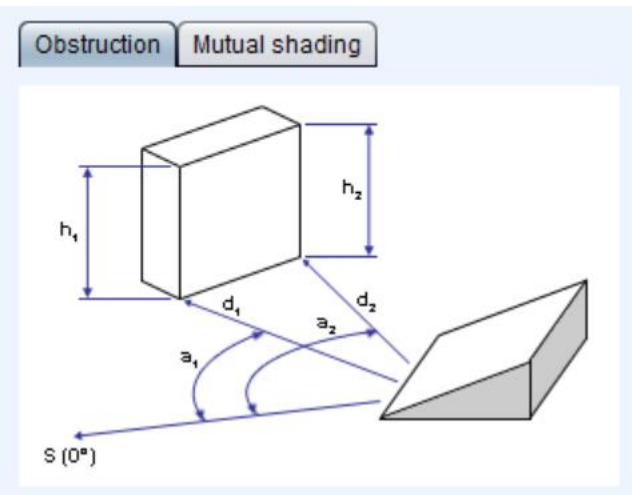
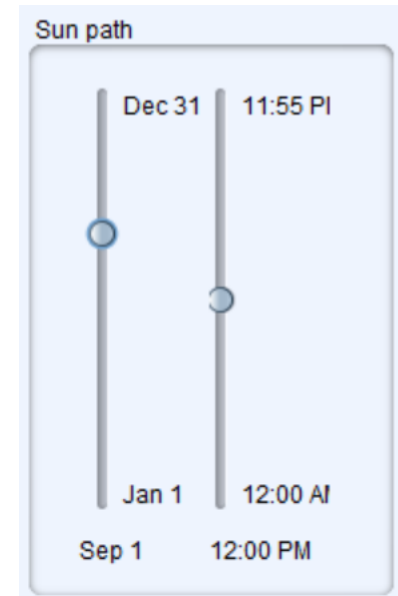
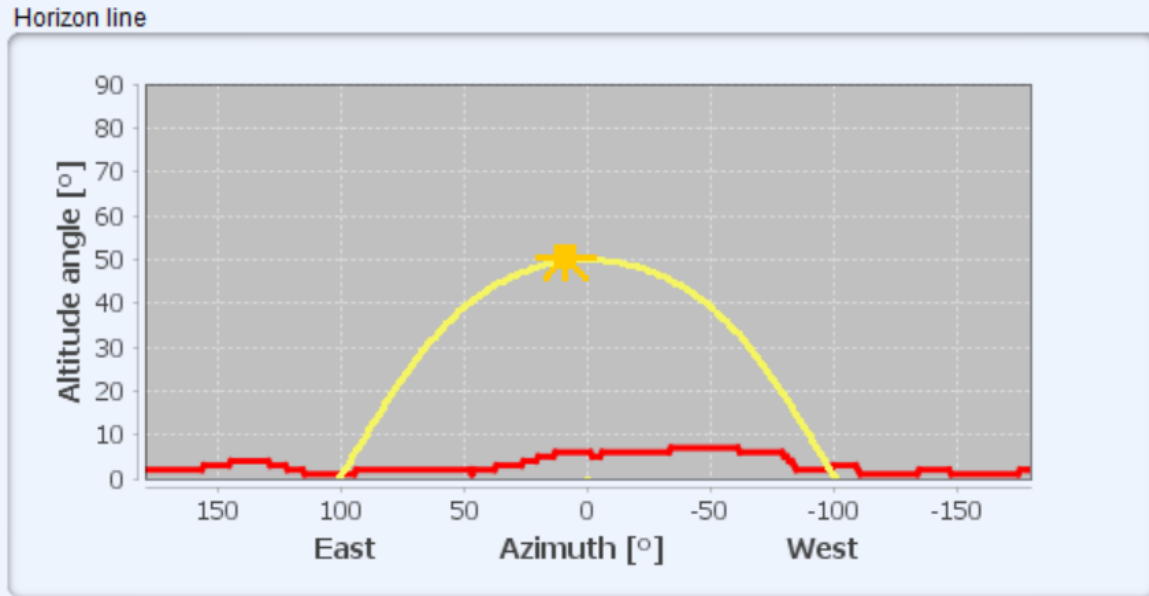

Read horizon from

Wizard helps you with choosing the right template

Wizard: Template



Project **Template**

Energy providers

Photovoltaics	Yes	All types
Solar thermal	No	All types
Boiler (oil, gas, wood, el.)	n/a	All types
Heat pump	n/a	All types
Chiller	n/a	All types

Selection of template

Select a template from the list. Use the filter on the left side to reduce or to enlarge the choice possibilities.

Number of available templates: 68

- Favorites
 - 50a: Photovoltaics
- Standard templates
 - Cooling systems
 - 73a: Space heating and cooling (water-water heat pump, ground-source loop)

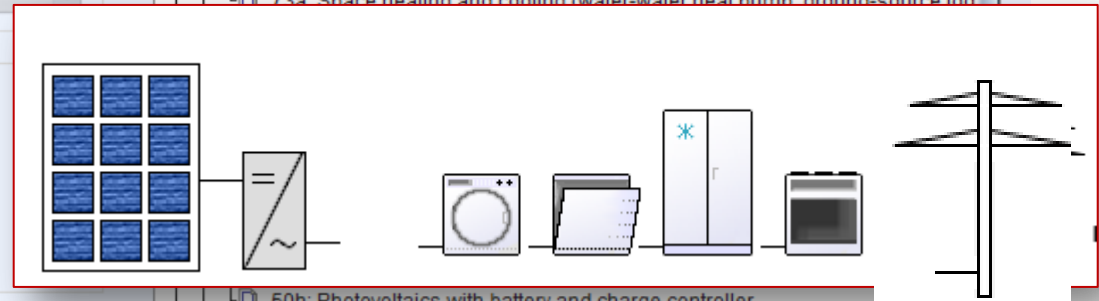

Consumers / Loads

Electric consumers	n/a
Domestic hot water	n/a
Space heating	n/a
Pool	n/a

System specification

System size	All types
Collector/Generator field	All types
DHW preparation method	All types
Template source / Company	All types

- 50h: Photovoltaics with battery and charge controller
- 50k: UPS with battery and PV
- 50l: UPS with battery, generator and PV
- 50o: PV with battery and forecast-based feed-in limitation
- 50p: PV with battery and forecast-based limitation of load peaks
- 50q: PV with battery and forecast-based limitation of load peaks and grid fee
- Photovoltaics (off-grid)
 - 50n: Photovoltaic off-grid system for street lights in Rome
 - 50i: Photovoltaic off-grid system
 - 50j: Photovoltaic off-grid system with generator
- Photovoltaics plus el. heat generation („power to heat“)
 - 52a: Space heating (heat pump + photovoltaics)

Back

Continue

Accept

Cancel

«Normal PV-System» → Polysun Wizard

Wizard: Grid

Project Template **Grid** PV generator field PV Bifacial PV design PV cables PV validation Electric consumers

Electric Grid

Choose the grid type from the catalog.

Grid type
Electric Grid

Feed-in - Phases
Maximum phase load imbalance ... Unlimited
cos φ

Feed-in power limitation
Maximum real power [%]
Limitation type

before consumption
after consumption

Tooltipp

Limiting active power:
PV-system can maximum 70% from the Peak-Power as an active power supply in the electricity grid.

«Normal PV-System» → Polysun Wizard

Wizard: PV generator field

Project Template Grid **PV generator field** PV Bifacial PV design PV cables PV validation Electric consumers

Photovoltaics: Generator field
Define the generator field (module type, number of modules).

Generator field

Module type	<input type="text" value="Photovoltaic module"/>	<input type="checkbox"/>
Orientation	<input type="text" value="0"/>	<input checked="" type="checkbox"/> Horizontal module orientation
Tilt angle	<input type="text" value="45"/>	
Roof width [m]	<input type="text" value="10"/>	
Roof depth [m]	<input type="text" value="8"/>	
Number of modules	<input type="text" value="10"/>	<input type="checkbox"/> Calculate

Module temperature

Minimum module temperature [°C]	<input type="text" value="-10.7"/>	<input checked="" type="checkbox"/> Calculate
Maximum module temperature [°C]	<input type="text" value="66"/>	

Back Continue Accept Cancel

Modules database:
Photovoltaikforum

www.photovoltaikforum.com

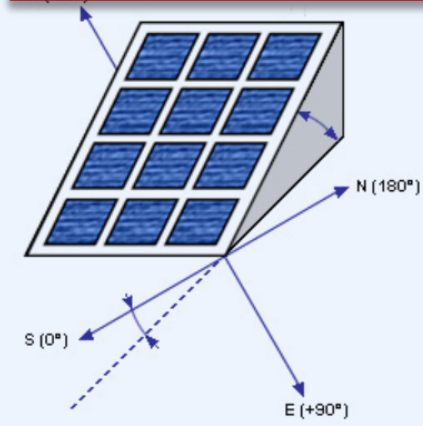

Automated inverter layout

Wizard: PV design

Project | Template | Grid | PV generator field | PV Bifacial | **PV design** | PV cables | PV validation | Electric consumers

Photovoltaics: Design assistant
Get appropriate proposals for the inverter/strings layout (inverter type, number of inverters, number of strings).

Filter

Minimum power ratio: Calculate

Maximum power ratio:

Manufacturer: Show only favorites

Max. inverter types:

Layout concept:

Layout variants
Select a line of the table to choose an inverter layout:

<input type="checkbox"/>	1 x Sunny Boy 1.5 [89%]
<input type="checkbox"/>	1 x Sunny Boy SB 1600TL-10 [94%]
<input type="checkbox"/>	1 x SB 1500 [100%]

Current selection
1 x Inverter 1300T

Manual inverter layout

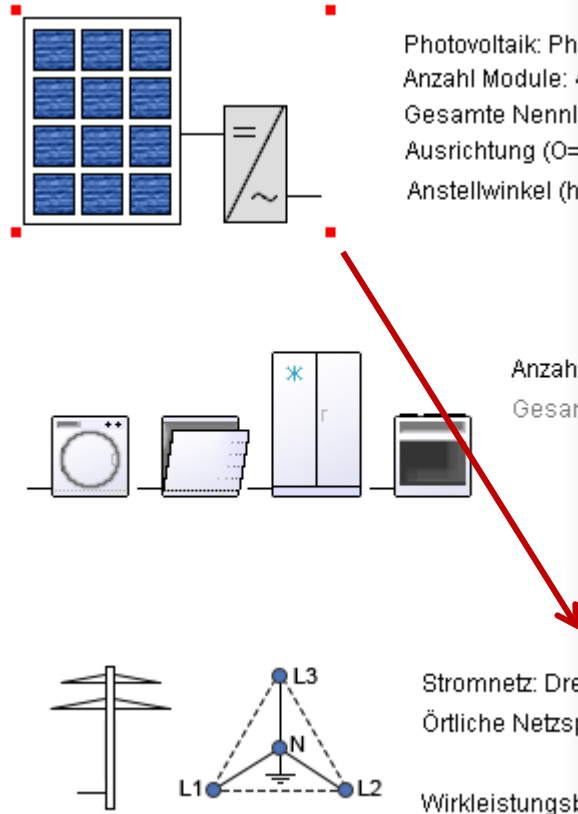

Photovoltaics Roof plan

@	Name	Value	Unit
	Description	Roof plan	
	Photovoltaics	☑ Photovoltaic module	
	- Manufacturer	Anonymous	
	- Module type	polycrystalline	
	- Galvanic separation required	No	
	- Nominal power STC	180	W
	- Width	0	m
	- Length	0	m
	- Gross area	1.4	m ²
	Reference value for the area	▼ Number of modules	
	Number of modules	42	
	Number of modules (layout)	42	
	Total nominal power generator field	7.56	kW
	Total gross area	58.8	m ²
A	Orientation (E=+90°, S=0°, W=-90°)	0	°
B	Tilt angle (hor.=0°, vert.=90°)	45	°
	Tracking	▼ No tracking	
	Wind fraction	50	%
	Rear ventilation	▼ medium	
	Soiling	2	%
	Degradation	0.5	%
	Cable losses calculation	▼ Loss factor	
	Cable losses	2	%
	Mismatching	4	%
	Inverter layout	▼ Manual	
	Number of inverter types	1	
	Layout 1: Inverter	☑ Inverter 2100	
	Layout 1: Number of inverters	3	
	Layout 1: A number of strings	2	
	Layout 1: A modules per string	7	
	Layout 1: A String fuse	0	A

PV-inverter testing









 Wizard: PV validation

Project | Template | Grid | PV generator field | PV Bifacial | PV design | PV cables | PV validation | Electric consumers

Photovoltaics: Validation

Validation of electrical limits of the inverter/strings layout.

 Overall validation 

Component	Validation	Value	Limit	Result
Inverter 1 Inverter 1300T	Power ratio Ratio between maximum DC power of the inverter and total nominal power of the generator field	83 %	-	
Inverter 1 Inverter 1300T	Max. input power Input power of modules at maximum radiation (Max. input power °C)	1,841 W	-	
Inverter 1 Inverter 1300T	Max. input voltage Open circuit string voltage (Max. input voltage °C)	340.9 V	500 V	
Inverter 1 Inverter 1300T	Min. MPP voltage MPP string voltage (Min. MPP voltage °C)	205.5 V	140 V	
Inverter 1 Inverter 1300T	Max. MPP voltage MPP string voltage (Max. MPP voltage °C)	270 V	410 V	
Inverter 1 Inverter 1300T	Max. input current MPP current of all strings (Max. input current °C)	7.6 A	12 A	
Inverter 1 Inverter 1300T	Minimum AC voltage Local grid voltage	230 V	190 V	
Inverter 1	Maximum AC voltage	230 V	255 V	



Results I

Modul temperature: maximum value

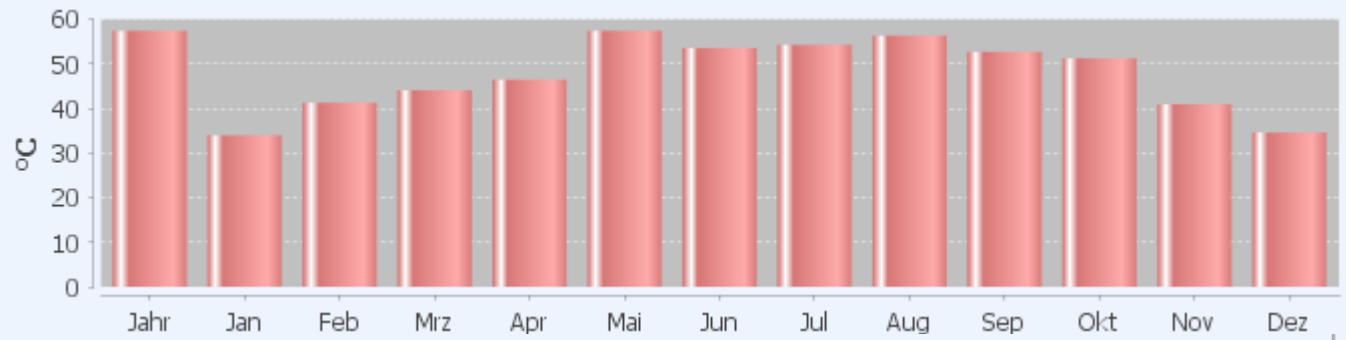

Electric Grid Electric consumers 1 **Photovoltaics Roof plan** Weather data

Results Photovoltaics Roof plan

Name	Symb...	Unit	Year	Jan	Feb	Mar	Apr	May	Jun	Jul	Aug	Sep	Oct	Nov	Dec
Radiation onto module area	Esol	kWh	17,365	752	1,014	1,472	1,785	1,993	1,966	2,175	2,056	1,759	1,181	667	544
Maximum value (Power)		W	16,340	11,920	14,461	14,937	14,817	16,340	14,444	16,194	15,410	16,053	14,293	12,594	11,909
Module temperature		°C	13.9	2.7	4.9	10.3	14.2	19.9	23.2	24.6	24.6	19.1	13.2	6	3.1
Minimum value		°C	-10.7	-10.7	-9.1	-4.3	-2.4	2	5.8	9.1	9.6	4.7	-0.4	-6	-8.2
Maximum value		°C	58.6	34.2	38.6	48	46.1	54.5	58.2	58.1	58.6	57.9	48.4	36.6	35.9
Efficiency module			0.109	0.104	0.112	0.114	0.113	0.108	0.109	0.109	0.108	0.109	0.109	0.105	0.105
Maximum value			0.135	0.135	0.133	0.13	0.129	0.126	0.123	0.122	0.122	0.126	0.13	0.131	0.133
Energy production DC	Qpvf	kWh	1,884	87	116	164	197	214	208	230	216	190	129	75	61
Maximum value (Power)		W	1,744	1,439	1,656	1,583	1,634	1,744	1,488	1,650	1,622	1,617	1,550	1,463	1,362
Efficiency inverter			0.785	0.658	0.763	0.815	0.821	0.796	0.832	0.829	0.815	0.804	0.786	0.704	0.678
Maximum value			0.92	0.92	0.92	0.92	0.92	0.92	0.92	0.92	0.92	0.92	0.92	0.92	0.92
Energy production AC	Qinv	kWh	1,708	78	105	149	178	194	188	209	196	172	117	67	55
Maximum value (Power)		W	1,500	1,313	1,500	1,440	1,485	1,500	1,356	1,499	1,474	1,469	1,411	1,334	1,245
Specific annual yield		kWh...	949	43.3	58.2	82.8	99.1	108	105	116	109	95.7	64.8	37.2	30.4
CO2 savings		kg	916	41.8	56.2	80	95.7	104	101	112	105	92.4	62.6	35.9	29.3
Cable losses	Qcbl	kWh	22	1	1	2	2	3	2	3	3	2	1	1	1
Maximum value (Power)		W	41	28	37	34	36	41	30	36	35	35	32	29	25
Overall inverter efficiency	εinv_...	%	90.6	90.1	90.6	90.8	90.8	90.6	90.7	90.9	90.9	90.9	90.4	89.6	89.3
Derating inverter	Qderi	kWh	0.1	0	0.000...	0	0	0.1	0	0	0	0	0	0	0
Maximum value (Power)		W	80.7	0	4.3	0	0	80.7	0	0	0	0	0	0	0
Derating losses	Qder	kWh	0.1	0	0.000...	0	0	0.1	0	0	0	0	0	0	0
Maximum value (Power)		W	80.7	0	4.3	0	0	80.7	0	0	0	0	0	0	0

Results II

- Radiation onto module area
- Energy yield AC
- Outdoor temperature

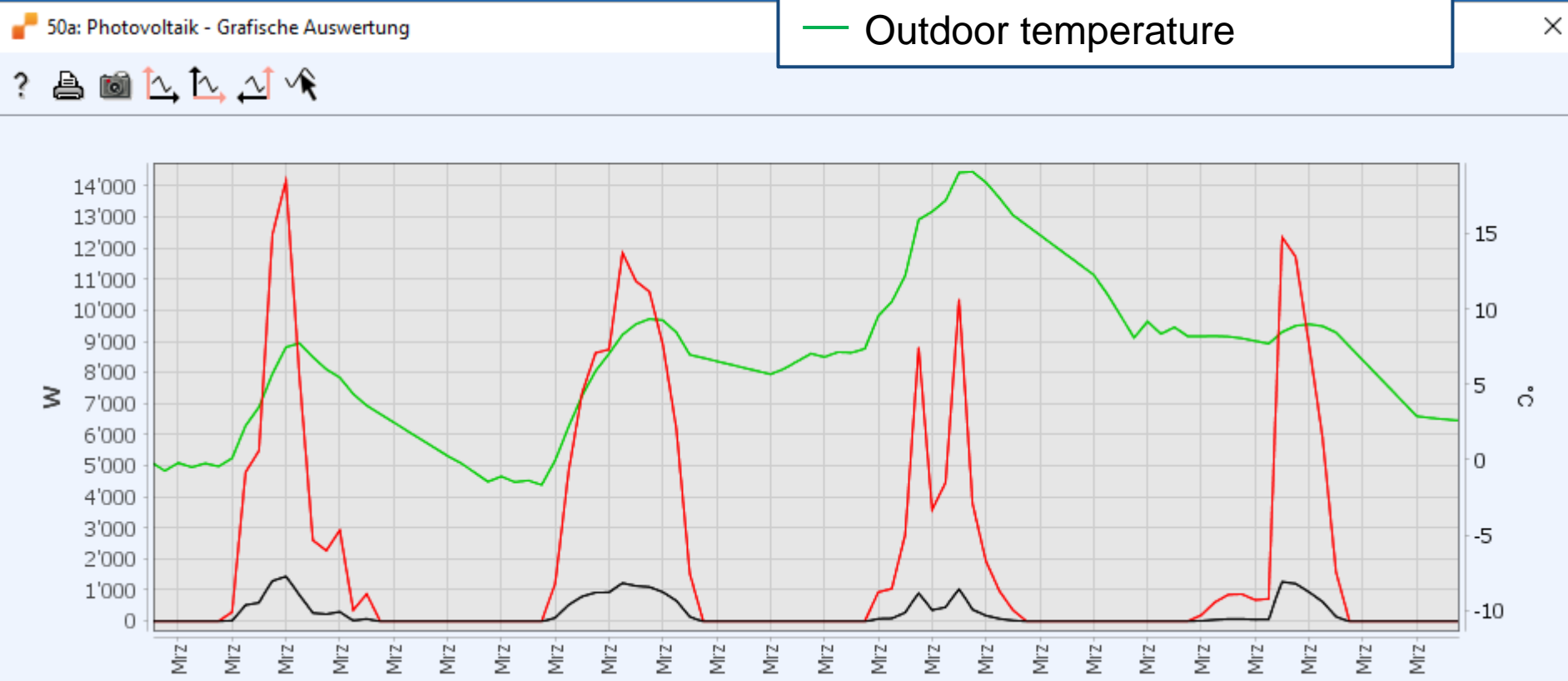

March 7th

March 8th

March 9th

March 10th

PV and self-consumption optimization

Wizard: Hot water

polysun[®]
SIMULATION
SOFTWARE

Project Template **Hot water** Building Heat generator Grid PV generator field

Hot water demand

You have selected a system with hot water. Now define the energy demand.

Domestic hot water

Computation base

Number of persons

Temperature [°C]

Is the annual demand known? Yes No

Daily hot water demand [l]

Absences

PV and self-consumption optimization



 Wizard: Building

Project Template Hot water **Building** Heat generator Grid PV generator field PV Bifacial

Building specification

Here you can parameterize the building model.

Space heating

Computation base	Building dimensions
Building	mily house, low-energy building
Length of building [m]	10.7
Width of building [m]	7
Number of floors	2
Heated/air-conditioned living area [m ²]	149.8
Heating setpoint temperature - day [°C]	19

Heating loop

Convactor (inlet/return temperature)	Floor heating
--------------------------------------	---------------

PV and self-consumption optimization

polysun[®]
SIMULATION
SOFTWARE

 Wizard: Heat generator

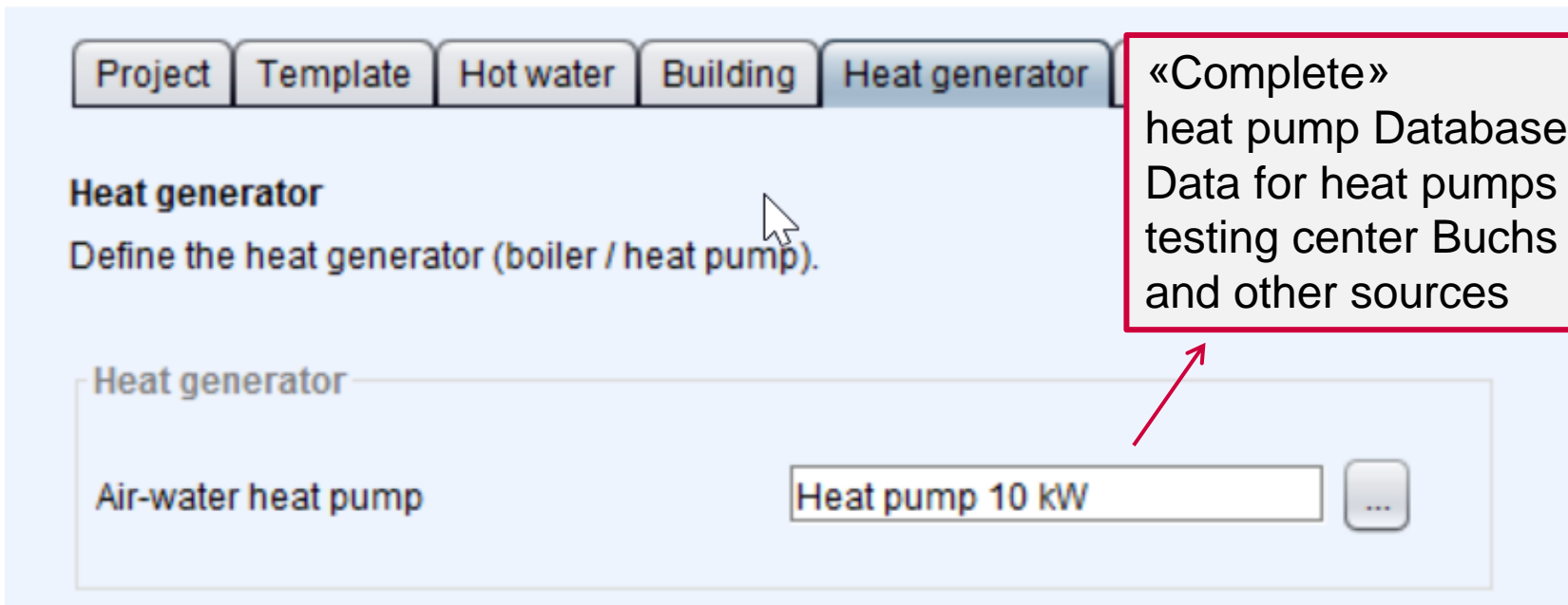

Project Template Hot water Building Heat generator

Heat generator
Define the heat generator (boiler / heat pump).

Heat generator

Air-water heat pump

Heat pump 10 kW

«Complete»
heat pump Database:
Data for heat pumps from
testing center Buchs NTB
and other sources

Storage system

- Battery storage
 - Battery capacity in kWh
 - Maximum charge-/discharge currents
 - Control strategy must be defined with electrical consumers and PV-System
- Thermal storage and/or heating
 - Storage tank for warm water and heating
 - Sizing the storage tank

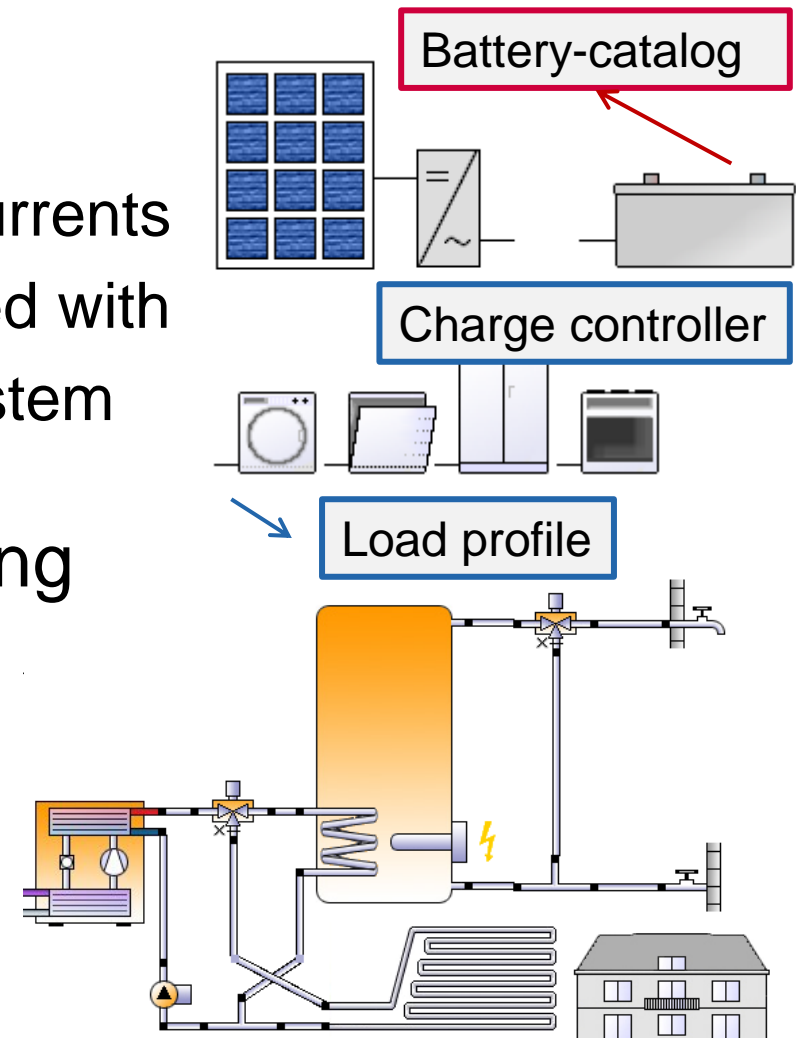

Electrical load profile in Polysun

Wizard: Electric consumers

Project Template Hot water Building Heat generator Grid PV generator field PV Bifacial PV design PV cables PV validation **Electric consumers**

Electric consumers

Add up to 10 electricity consumption profiles and let Polysun calculate the self-consumption.

Electric consumers

Number of electricity consumption profiles

1

Consumption profile 1

Residential profile

Annual consumption [kWh]

3,500

Profile - Catalog

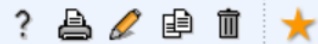

Show only favorites

Catalog no.	Name	Profile type	File name
21	Residential profile	Electricity consumption	60.csv
22	Standard load profile BDEW	Electricity consumption	61.csv
27	Residential profile: 2 families	Electricity consumption	60-2.csv
28	Residential profile: 3 families	Electricity consumption	60-3.csv
29	Residential profile: 4 families	Electricity consumption	60-4.csv
30	Residential profile: 5 families	Electricity consumption	60-5.csv
31	Load profile H01: couple, aged under 30, both working	Electricity consumption	eload_H01
32	Load profile H02: couple, aged 30 - 64, both working	Electricity consumption	eload_H02
33	Load profile H03: couple, aged 30 - 64, 1 working, 1 at home	Electricity consumption	eload_H03
34	Load profile H04: family, 1 child, both parents work	Electricity consumption	eload_H04
35	Load profile H08: single working mother with 2 children	Electricity consumption	eload_H08
36	Load profile H09: single working woman, aged 30 - 64	Electricity consumption	eload_H09
37	Load profile H10: single man, aged 30 - 64, shift worker	Electricity consumption	eload_H10
38	Load profile H11: student	Electricity consumption	eload_H11

Results

Overview:

Name	Symbol	Unit	Year
Yield Photovoltaics AC	Qinv	kWh	7,196.9
Self-consumption	Eocs	kWh	1,481.6
To external grid	Eteg	kWh	5,715.3
From external grid	Efeg	kWh	2,018.4
Heat generator energy to the system (solar thermal energ...	Qaux	kWh	11,576
Total energy consumption	Quse	kWh	10,816
Energy deficit	Qdef	kWh	56.2
Total fuel and/or electricity consumption of the system	Etot	kWh	610
Primary energy factor	eP		0.4

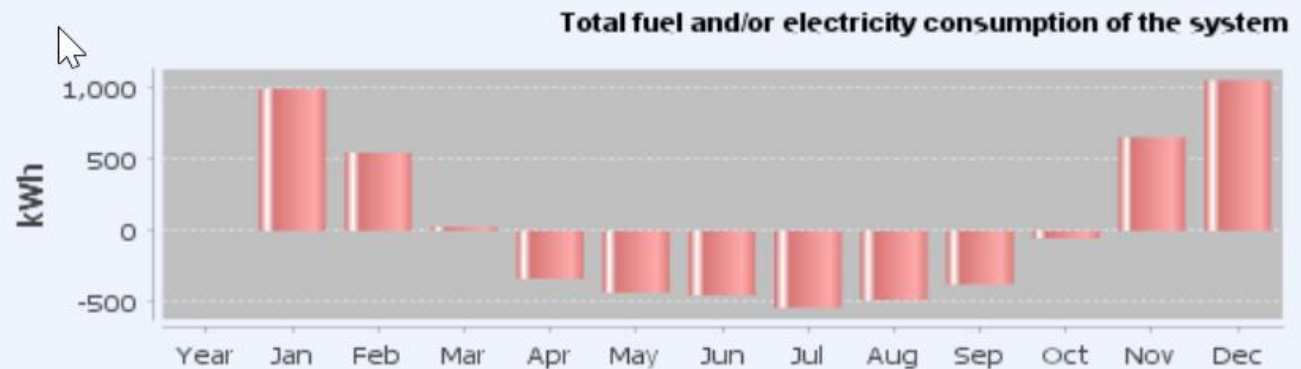

Typical optimization in hybrid systems:

- PV self-consumption ↔ Degree of self-sufficiency
- Investment costs ↔ Operating costs

Results

Name	Symb...	Unit	Year	Jan	Feb	Mar	Apr	May	Jun
Degree of self-sufficiency	Raut	%	42.3	22.9	33.5	46.9	53.2	56.2	60.5
Self-consumption fraction	Rocs	%	20.6	24.9	23.8	24.3	20.7	18.9	18.8
Feed-in ratio	Rocsp	%	79.4	75.1	76.2	75.7	79.3	81.1	81.2
Self-consumption	Eocs	kWh	1,482	82.1	105	153	155	155	149

Degree of self-sufficiency

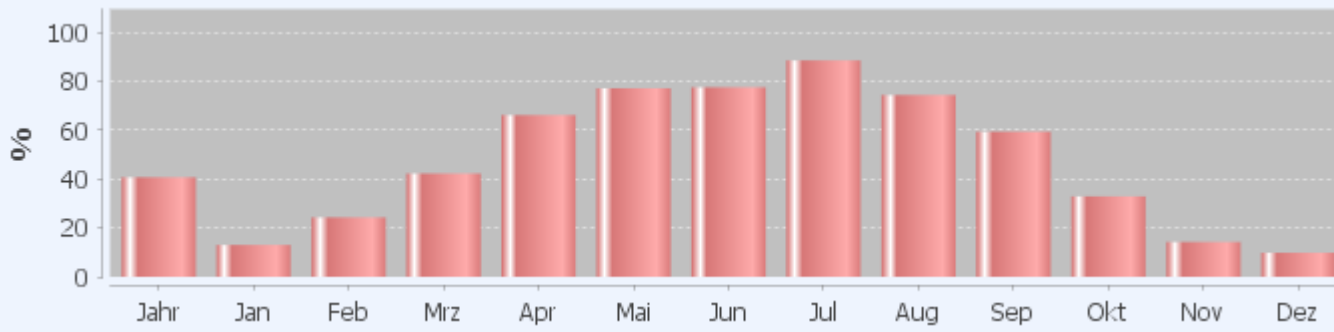

Minimum value (Power) W 129 168 160

Self-consumption

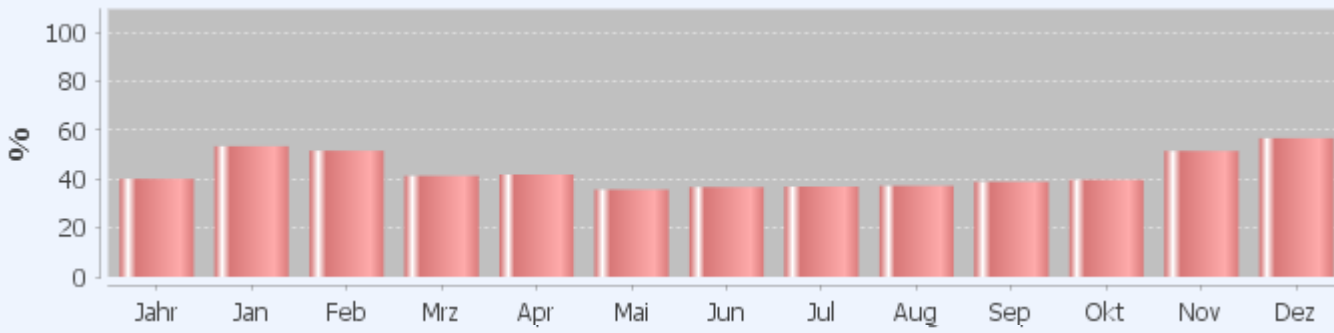

840	768	690	617
153	155	155	149
840	768	690	617
24.3	20.7	18.9	18.8
475	596	662	645
5,503	5,714	6,016	5,268
173	136	120	97.3
856	734	660	516
628	752	816	794
6,080	6,273	6,688	5,719
325	292	275	246
150	144	137	131
856	768	690	617
330	125	111	96.3
4,756	4,756	4,756	4,758
325	292	275	246
150	144	137	131
856	768	690	617

Energy flow diagramm

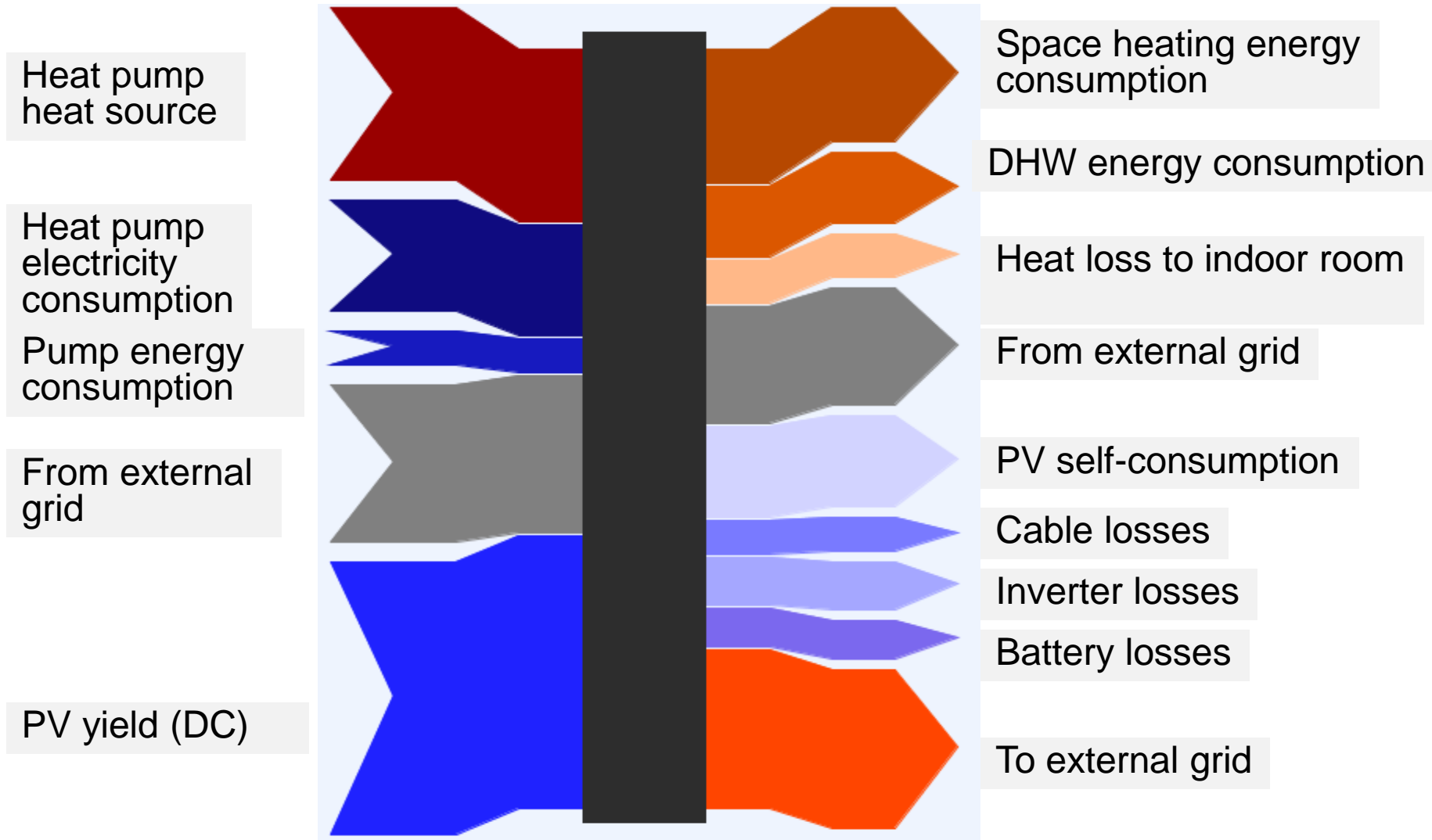

Detailed simulation analysis

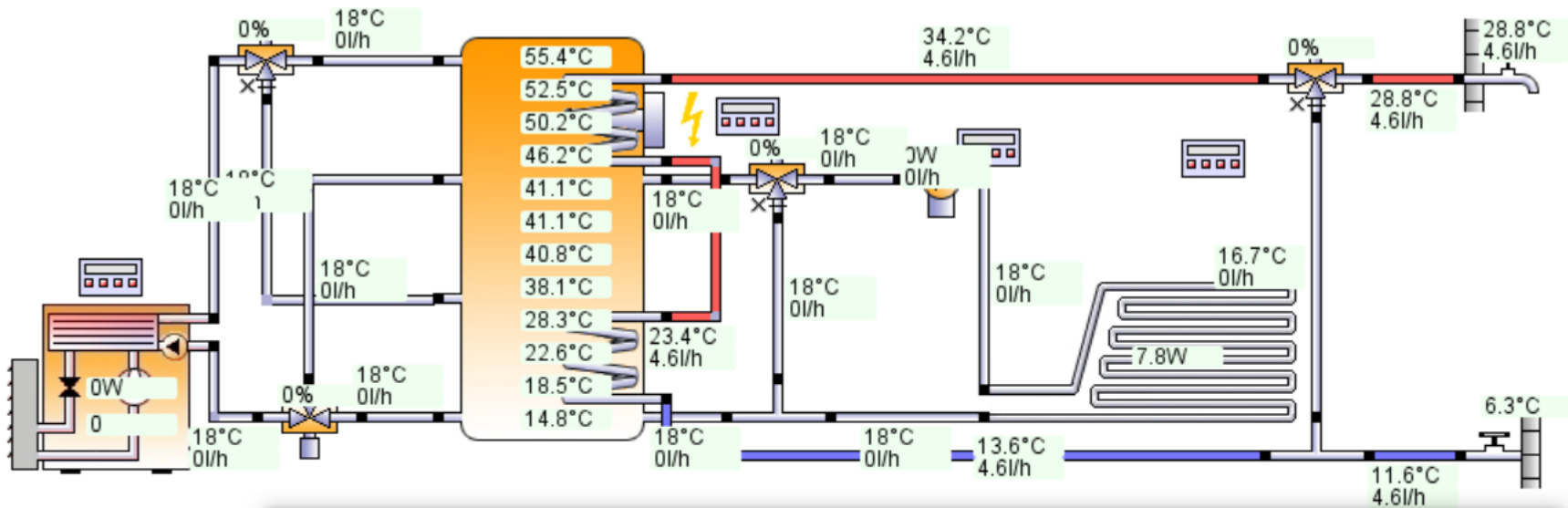

System diagram 52a: Space heating (heat pump + photovoltaics) - Simulation analysis

Simulation time: January 26, 3:00:01 AM (2170801s, 603h) Simulation step: 11312

- [Slider] +

Simulate Close

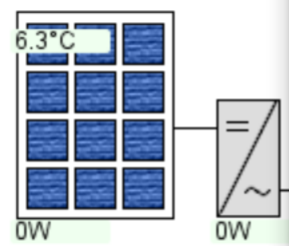

- Every time-step is reflected

Example: PV self-consumption in Polysun

Very often there is no good agreement between electrical consumption and PV-generation

polysun[®]
SIMULATION SOFTWARE

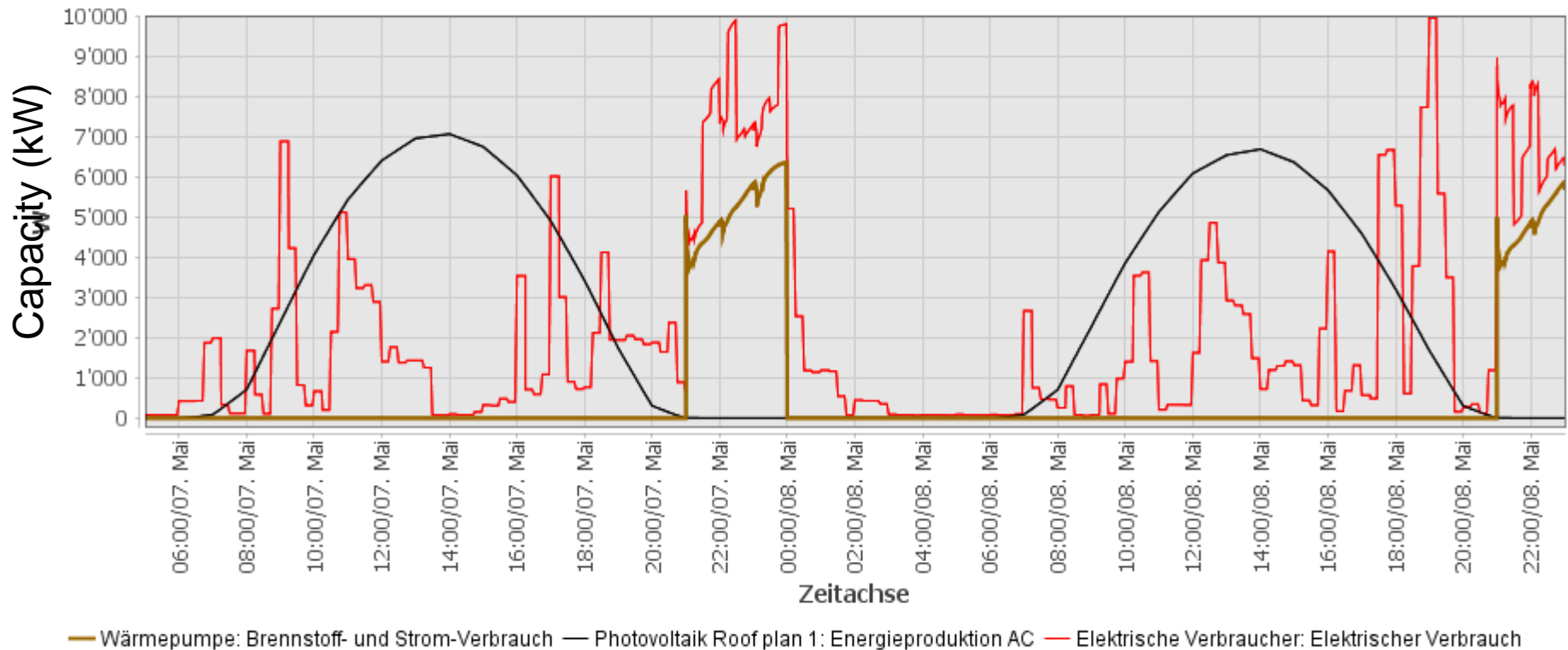

May 7th

May 8th

Time

swissuniversities

Example: PV self-consumption in Polysun

A heat pump operates normally at night

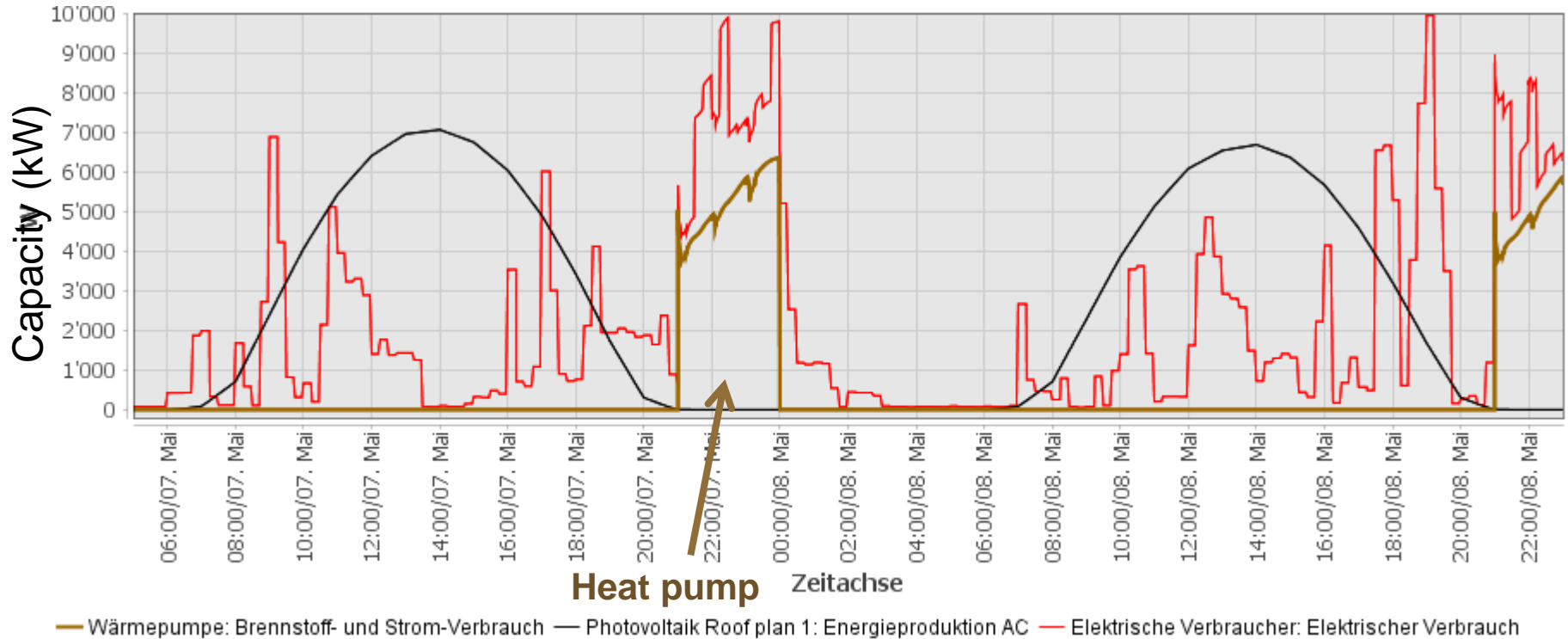

May 7th

May 8th

Time

Controller in Polysun

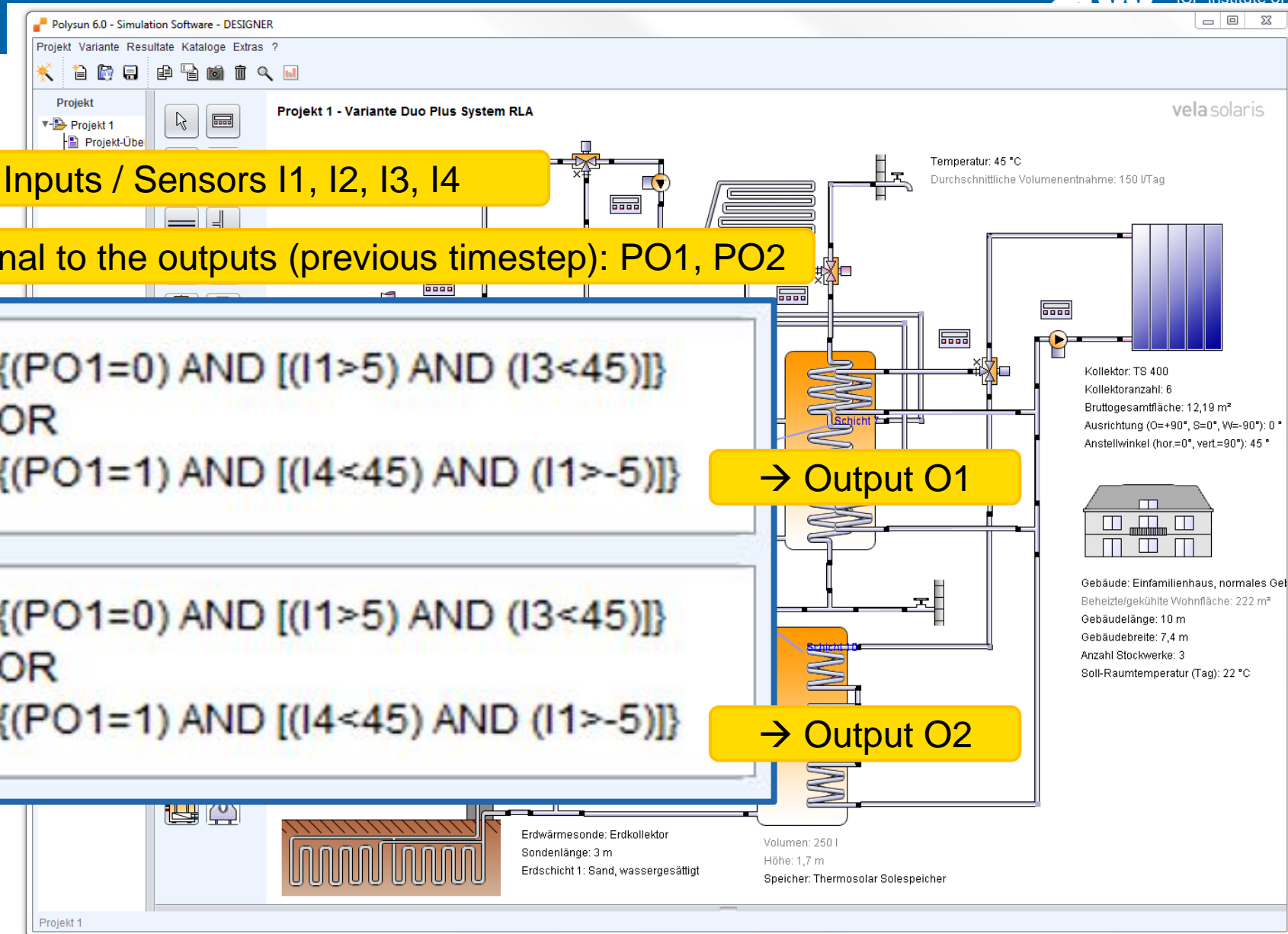

Example: PV self-consumption in Polysun

Load adjustment: the heat pump operates when energy is generated from PV-field

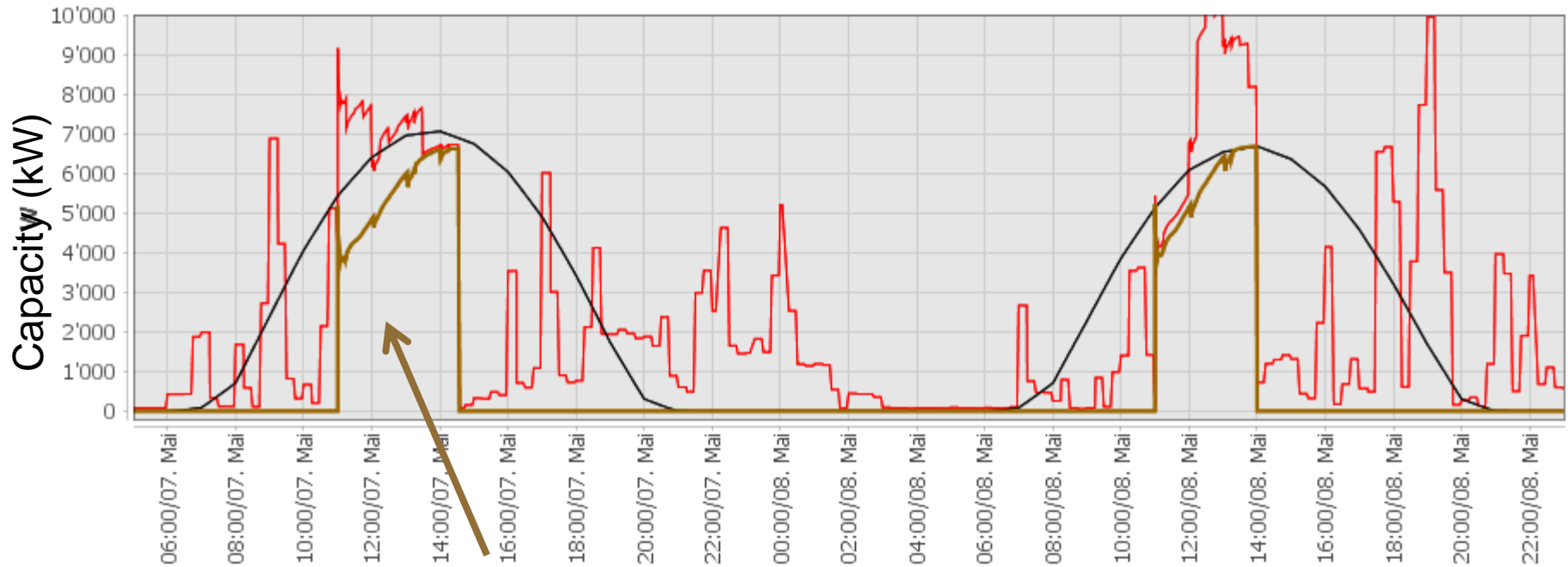

Heat pump with load adjustment

May 7th

May 8th

Time

Example: PV self-consumption in Polysun

polysun[®]
SIMULATION

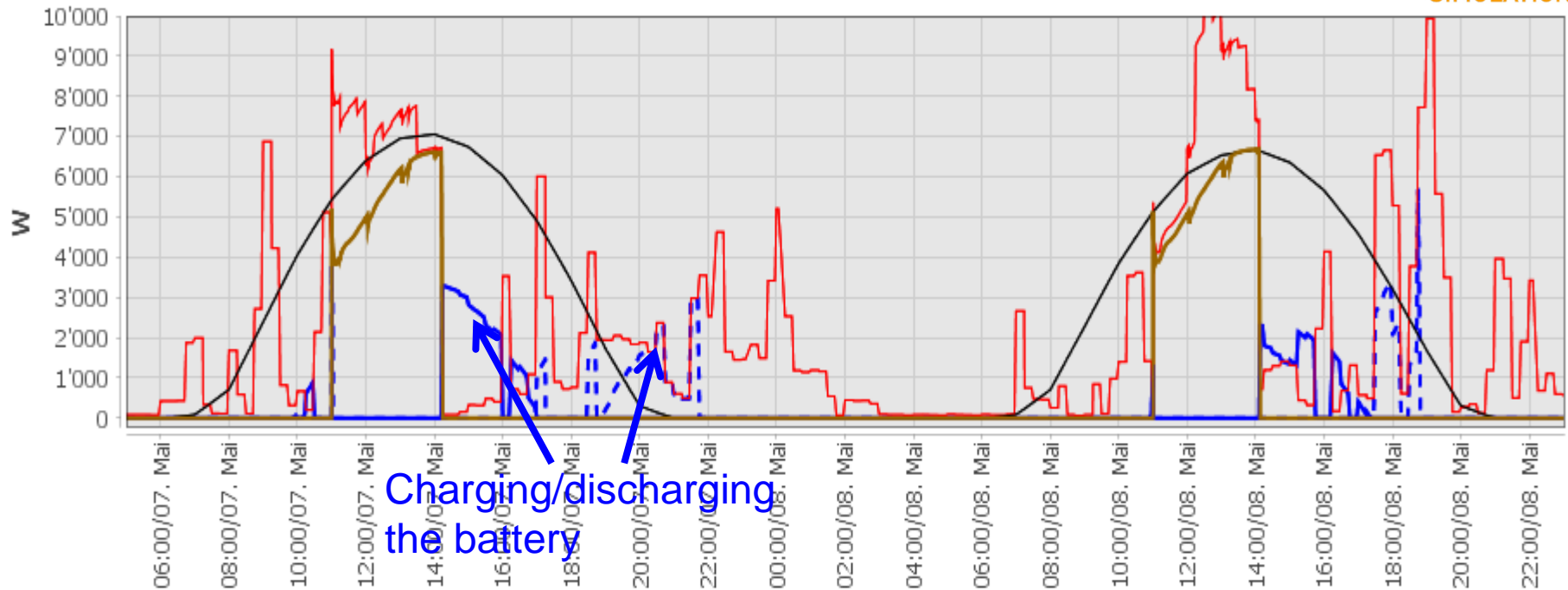

Load strategy: Where shall PV-energy be transferred?

- 1) el. consumers
- 2) battery
- 3) grid

Polysun «Smartgrid»

Local load-management

- Linking heat pump and PV production and PV production
- Modulated heat pump
- Battery storage
- Co-generator
- Ground-source loop

polysun®

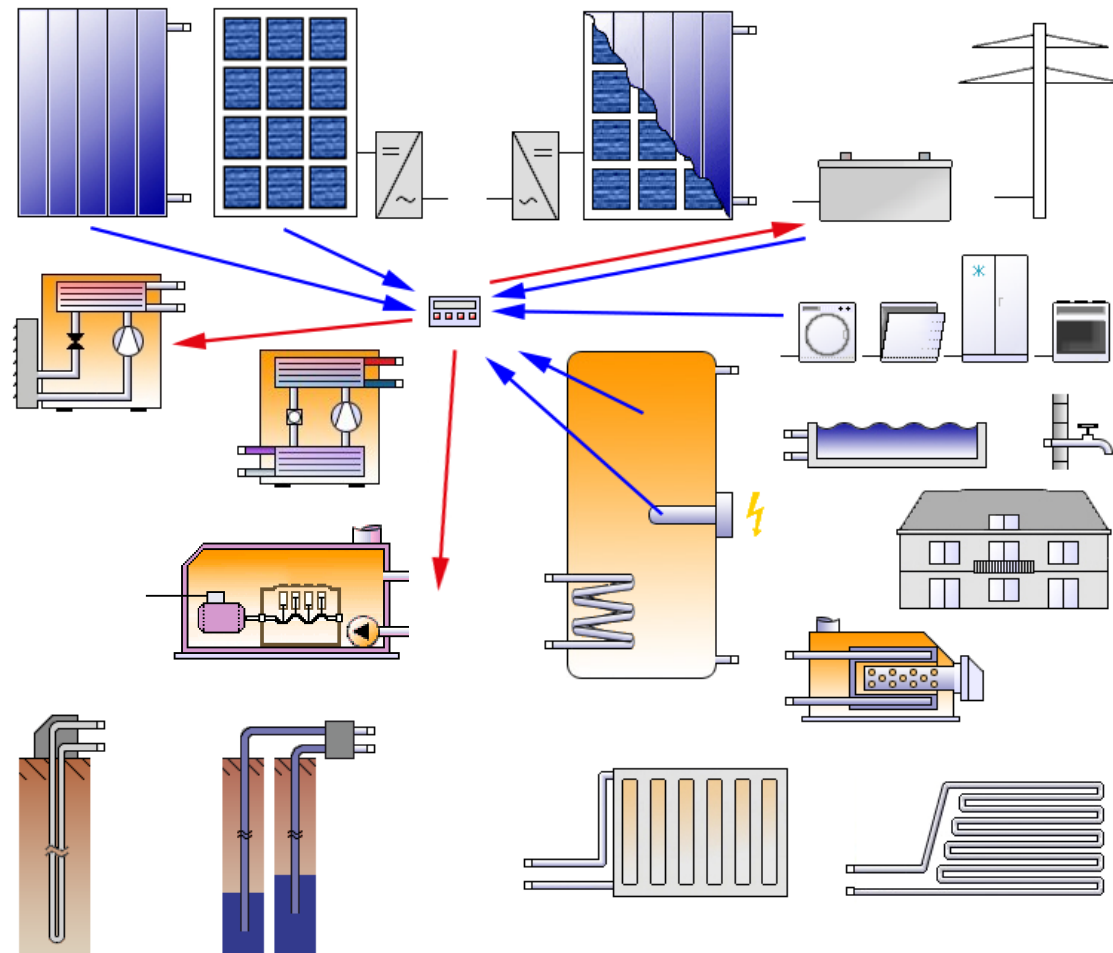

PV + Battery + Heat pump

Possible control strategies. Goal: to avoid peaks in the el. grid

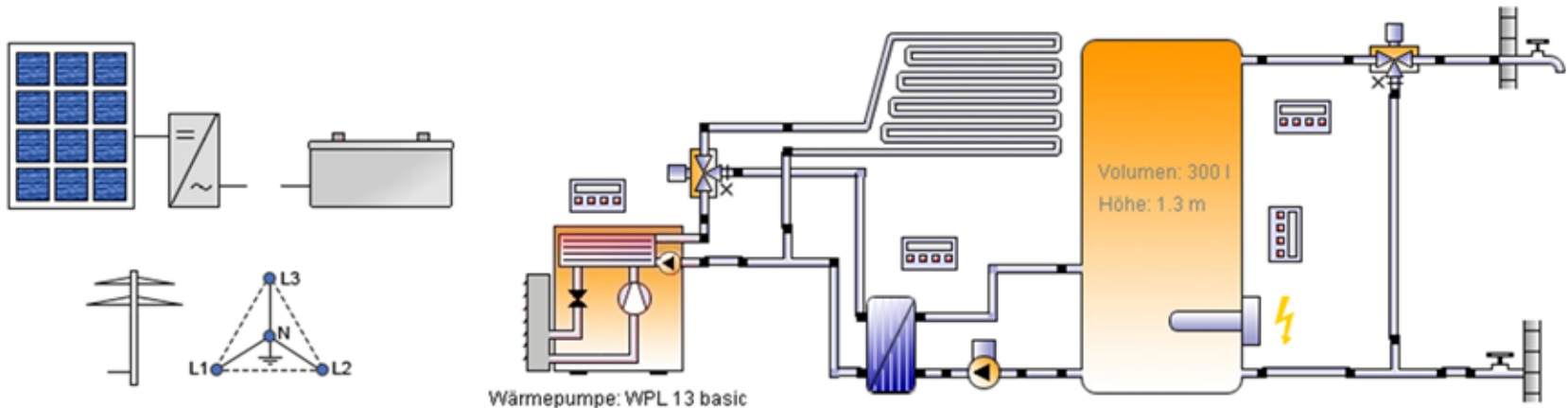
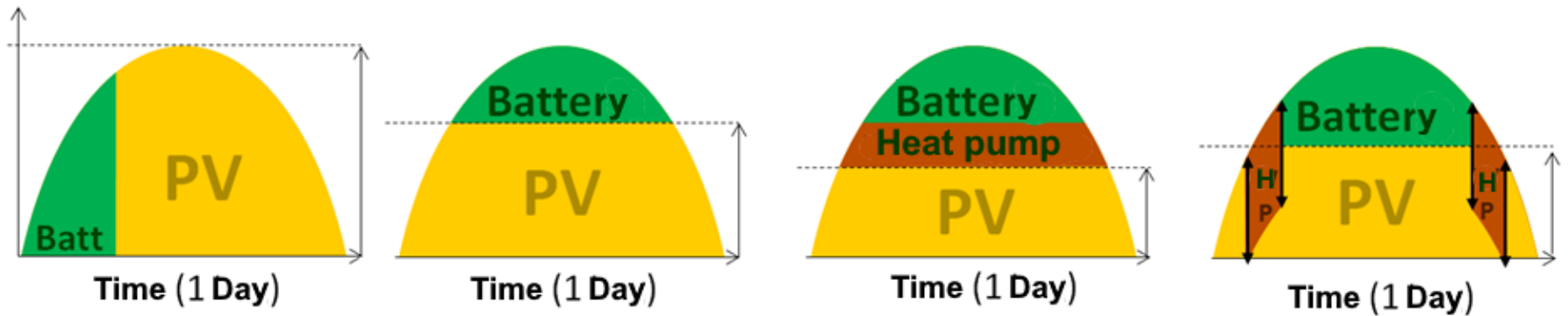

Real Situation

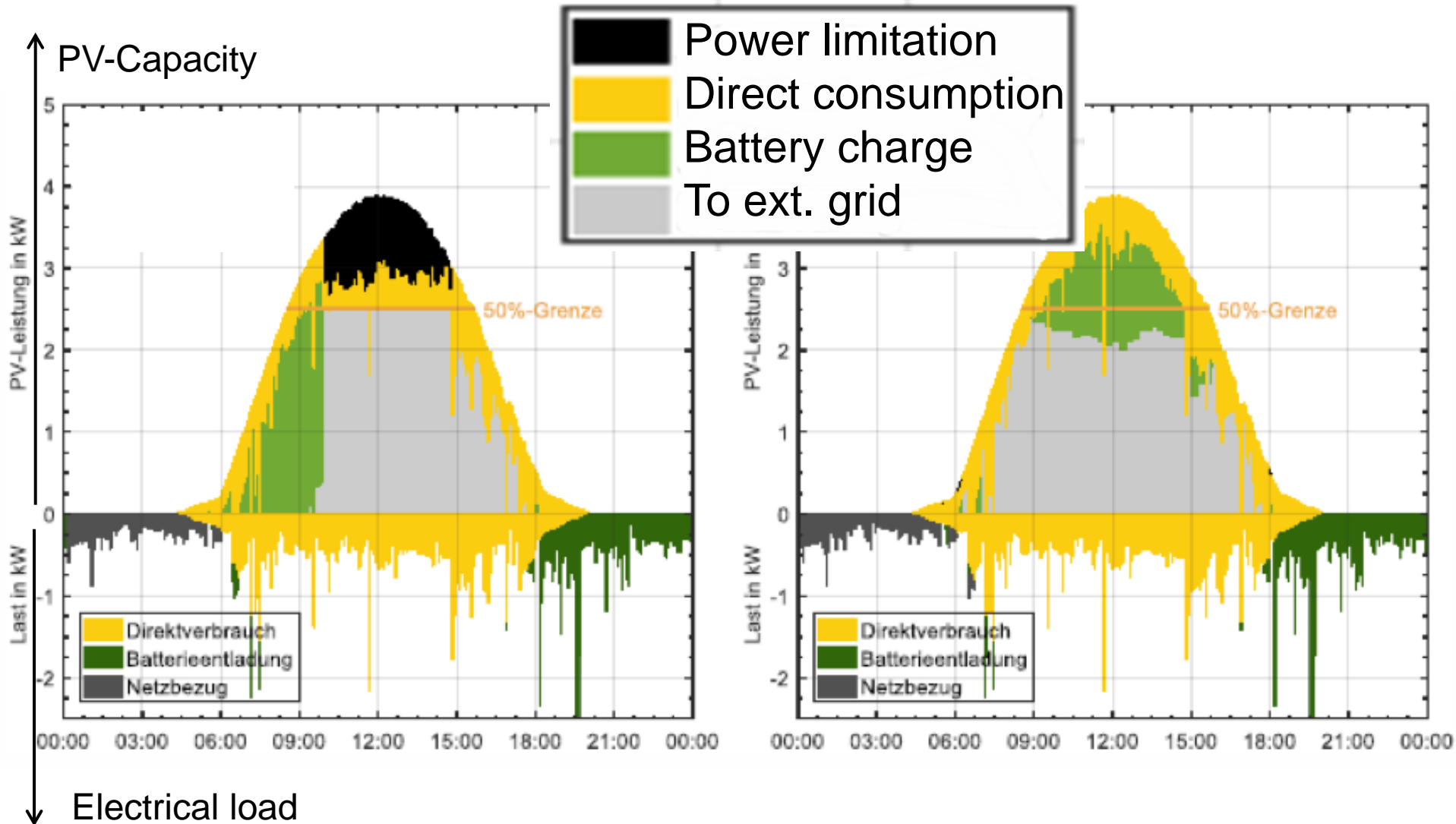

Cooperation with inverter-producer SMA

SUNNY DESIGN WEB | English ▾

Select project type

Select the type of project you wish to design:

- PV project**
Design PV system without self-consumption
- PV project with self-consumption**
Design PV system with self-consumption
- PV project without grid connection**
Design an off-grid system
- PV hybrid project**
Design PV hybrid system

Adopt this project type as default setting

[» Own price list](#)

Version 3.54.0

- Inverter producer SMA supports PV-self-consumption
- Polysun is used for the simulation of DHW preparation, thermal storage, building and heat pump – heating.

SMA Sunny Design



▼ PV arrays					
Name	Manufacturer / PV module / module level power electronics			Number of PV modules/Peak power	Orientation/Mounting type
1 PV array 1	.SMA SMA Demo Poly 240	<i>i</i>	🔍	66 PV m 15.84	
<div style="background-color: #0056b3; color: white; padding: 5px; display: inline-block;">+ Add PV array</div>					

Distribution of PV energy

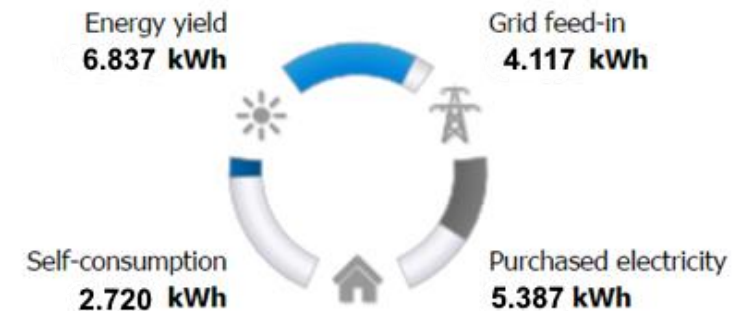

PV self-consumption



Heat pump for heating and DHW
Capacity: 2,68 kW
Electricity demand: 3.106,99 kWh

Building:
Heating area:
Warm water:

Passive house
200 sq.m
400 l/d

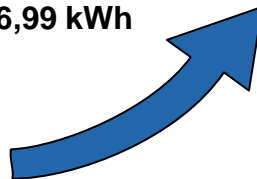

Degree of self-sufficiency



PV sel-consumption





Vela Solaris, Stadthausstr. 125,
Winterthur
www.velasolaris.com



All in one tool.

EXPO 2017
• **Future Energy** •
Astana Kazakhstan

Swiss Pavilion
25th/26th August, 2017
Polysun Workshop

Andreas Wolf
andreas.wolf@velasolaris.com

Thank you

Спасибо

Danke

Рақмет

Merci

Grazie

Grazia

