

**MOVING OBJECT DETECTION WITH MEMRISTIVE CROSSBAR  
ARRAYS**

**Sultan Duisenbay, Bachelor of Engineering**

**Submitted in fulfillment of the requirements  
for the degree of Master of Science**



**School of Engineering  
Department of Electrical and Electronic Engineering  
Nazarbayev University**

53 Kabanbay batyr Avenue,  
Astana, Kazakhstan, 010000

December 9

# Abstract

This thesis is dedicated to the hardware implementation of a novel moving object detection algorithm. Proposed circuit includes several stages, each of which implements a particular step of the algorithm. Four higher bit planes are extracted from a grayscale image and stored in memristive crossbar arrays, and the respective bit planes are compared via memristive threshold logic gates in XOR configuration. In the next stage, compared bit planes are combined by weighted summation, with a highest weight assigned to MSB plane and smaller weights for less significant bit planes. After summation stage, obtained grayscale image is thresholded to obtain binary image. The last stage is implemented via memristive content-addressable memory array, which serves two purposes. It is used as a long-term memory in comparison to crossbar arrays, which serve as a short-term memory of proposed circuit. Content-addressable memory is updated based on the row-by-row difference between first and second pair of frames processed by previous stages. It also allows for analysis of object movement direction and velocity by observing the row capacitors' discharge. Simulations show that accuracy of proposed circuit operation is increased with the larger array size. Delay analysis of the circuit is carried out, power and area calculations show that proposed circuit is a viable candidate as a co-processing operator for existing image sensors.

# Acknowledgments

First and foremost, I would like to express my sincere gratitude to my professor, mentor and coordinator Dr. Alex James Pappachen. His guidance and support were essential in the course of writing this thesis. Dr. James was very helpful in explaining and clarifying the issues that arose during research work. Based on his advice, I was able to make significant improvement into thesis and achieve satisfactory results.

In addition to this, I am very thankful to Nazarbayev University library for provision of access to online research databases, which formed a basis for extensive and nurturant literature review.

# Contents

<b>Acknowledgments</b> .....	ii
<b>List Of Figures</b> .....	v
<b>List of Tables</b> .....	vi
Chapter 1 – Introduction .....	1
Chapter 2 – Literature review .....	2
2.1 Memristor . . . . .	2
2.2 Crossbar array . . . . .	4
2.3 Threshold logic . . . . .	7
2.4 Content-addressable memory . . . . .	10
Chapter 3 – Methodology .....	12
3.1 Memristive crossbar arrays . . . . .	13
3.2 Threshold logic gates . . . . .	15
3.3 Weighted summation and tresholding circuit . . . . .	17
3.4 Content-addressable memory . . . . .	19
Chapter 4 – Results .....	22
4.1 Crossbar array . . . . .	22
4.2 Threshold logic gates . . . . .	24
4.3 Weighted summation and thresholding . . . . .	25
4.4 CAM array . . . . .	26
4.5 Delay and pulse duration . . . . .	26
4.6 Accuracy, power & area . . . . .	27
Chapter 5 – Discussions and conclusions .....	29

# List of Figures

Figure 2.1	Circuit elements connecting four fundamental circuit variables	2
Figure 2.2	HP prototype memristor model	4
Figure 2.3	Simple crossbar structure	5
Figure 2.4	Sneak path representation during the read phase	6
Figure 2.5	Hybrid memristive crossbar/CMOS system design	7
Figure 2.6	Hybrid tiled memristive crossbar design	8
Figure 2.7	Hybrid memristive/CMOS linear threshold logic gate in (a) NAND & NOR configuration, (b) XOR configuration	9
Figure 2.8	Basic content-addressable diagram depicting search and match lines	10
Figure 2.9	Memristive CAM cell in 2T-2M topology	11
Figure 3.1	Block diagram of circuit simulation stages	12
Figure 3.2	Hardware block diagram of the proposed circuit	13
Figure 3.3	Memristor crossbar array write cycle	14
Figure 3.4	Memristor crossbar array read cycle	15
Figure 3.5	Bit sequence "1101" stored and extracted from memristive crossbar array	15
Figure 3.6	Memristive crossbar arrays integrated with memristive threshold logic gates	16
Figure 3.7	Timing diagram showing the operation of TLG in XOR configuration	17
Figure 3.8	Weighted summing circuit stage	18
Figure 3.9	Voltage waveforms generated by weighted summing stage	19
Figure 3.10	Op amp comparator embedded into weighted summing circuit stage	19
Figure 3.11	Timing graph showing the weighted summing generated voltage being thresholded	20
Figure 3.12	Memristive CAM array circuit in 2T-2M topology with the discharge path in red	20

Figure 3.13	Write and read cycles for memristive CAM array. (a) write cycle, (b) read cycle .....	21
Figure 4.1	Original grayscale images for frames #1, #2, and #3 with higher order bit planes. (a),(f),(k) Original grayscale image, (b),(g),(l) MSB plane, (c),(h),(m) 6th bit plane, (d),(i),(n) 5th bit plane, (e),(j),(o) 4th bit plane .....	23
Figure 4.2	Bit planes stored to and extracted from crossbar array by using MATLAB. (a)-(d) bit planes of frame #1, (e)-(h) bit planes of frame #2, (i)-(l) bit planes of frame #3 .....	23
Figure 4.3	Manually XORed bit planes of the first (a)-(d) and second (e)-(h) pair of consecutive frames. (a),(e) - MSB, (b),(f) - 6th bit, (c),(g) - 5th bit, (d),(h) - 4th bit .....	24
Figure 4.4	XORed bit planes of the first (a)-(d) and second (e)-(h) pair of consecutive frames derived from threshold logic gate. (a),(e) - MSB, (b),(f) - 6th bit, (c),(g) - 5th bit, (d),(h) - 4th bit .....	24
Figure 4.5	Grayscale and thresholded images from weighted addition manually (a),(b) and from circuit(c),(d). (a),(c) first pair of frames, (b),(d) second pair of frames .....	25
Figure 4.6	Capacitor voltage discharge curves for match and mismatch cases .....	26
Figure 4.7	Voltage waveforms obtained after each stage .....	27
Figure 4.8	Sensitivity graph showing dependence of accuracy on temperature	

# List of Tables

Table 3.1	Truth table for TLG operation in XOR configuration . . . . .	16
Table 4.1	Delay and changes in pulse duration after each stage . . . . .	27
Table 4.2	Accuracy, area and power for different array size . . . . .	28

# Chapter 1 – Introduction

This thesis focuses on hardware implementation of the moving object detection algorithm presented in "Moving object detection using bit-plane slicing" thesis by Nazgul Dastanova. The key objectives of this thesis include step-by-step hardware simulations by proper design and choice of circuit elements and stages. These stages comprise:

1. Storage of binary images in short-term memory
2. Comparison of binary images
3. Combination of binary images to obtain grayscale image
4. Thesholding of the grayscale image
5. Storage of binary images in longer-term memory

Circuit simulations are implemented mostly based on memristive elements, which have found many applications in digital (memory and logic) [1], [2], [3], [4], [5] and analog (oscillators, amplifiers, and comparators) circuits [6], [7], [8]. In this thesis, memristors are utilized in digital manner, with the binary state being memorized in them.

The motivation behind this work lies in the internet-of-things (IOT), which has started encompassing almost every aspect of human life. Increased attention is paid to smart technologies connected over network to allow automation and intelligence. Particularly within IOT, we want to focus on video-over-IOT using existing image sensors and transmission devices. Bearing this in mind, proposed circuit could be potentially implemented in security, law enforcement and military applications.

# Chapter 2 – Literature review

## 2.1 Memristor

Leon Chua, nonlinear circuit theorist, realized the symmetric connection in three basic passive circuit elements (capacitor, inductor, resistor) in 1971 [9]. By analyzing the fact that there are four fundamental variables from a circuit's point of view (i.e. flux linkage  $\phi$ , charge  $q$ , voltage  $v$ , current  $i$ ), he suggested the existence of a fourth circuit element. Four fundamental variables should have been connected with each other via basic circuit elements: inductor connecting the flux linkage  $\phi$  with the current  $i$ , capacitor connecting the voltage  $v$  with the charge  $q$ , and resistor connecting the voltage  $v$  with the current  $i$  [10]. Based on the missing relationship between the flux linkage  $\phi$  and charge  $q$ , Chua argued about the existence of fourth circuit element connecting those fundamental variables by:

$$d\phi = M dq \quad (2.1)$$

where  $M$  represents memristance, parameter of the theoretical circuit element.

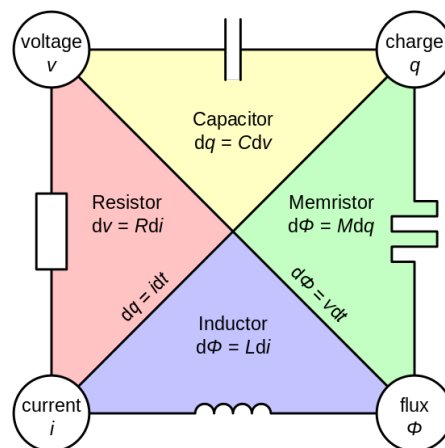

*Figure 2.1: Circuit elements connecting four fundamental circuit variables*

This theorized circuit element was named as a memory resistor, or memristor in short, since it could remember previous state. Memristor shares the same characteristics as potentiometer in changing the active resistance; however, it is a two-terminal device, where the effective resistance is altered by applying specific voltage across device terminals [11]. The memristor has been physically implemented only after more than 40 years in 2008 by HP Labs [12].

Theory behind the memristor prototype produced by HP Labs is discussed in [13]. Figure 2.2 shows the HP prototype memristor model. Prototype is implemented by putting a thin two-layer titanium dioxide ( $TiO_2$ ) film between platinum contacts. By introducing oxygen vacancies into one film, semiconductor property is enhanced, while the undoped region remains as an insulator [14]. The resistance is changed by modulating the width of doped region based on charge passing through device. The doped region boundary is moved in the direction of passing current [13]. The total resistance of element  $R_{MEMRISTOR}$  is calculated by:

$$R_{MEMRISTOR}(x) = R_{ON}x + R_{OFF}(1 - x), \quad (2.2)$$

where  $x$  is the ratio of doped region width to total width of memristor,  $R_{ON}$  and  $R_{OFF}$  are resistances for fully undoped region (insulator) and fully doped (semiconductor) regions respectively.

Many factors, including resistances of doped area, current, and other factors, have an effect on boundary movement speed, which is given by:

$$\frac{dx}{dt} = ki(t)f(x) \quad (2.3)$$

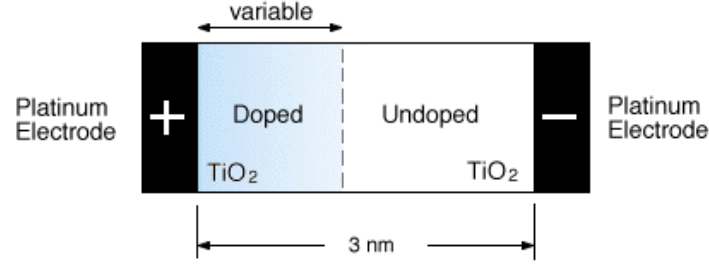

*Figure 2.2: HP prototype memristor model*

$$k = \frac{\mu_v R_{ON}}{D^2} \quad (2.4)$$

where  $D$  is total memristor width, and  $\mu_v$  is dopant mobility.

HP memristor is susceptible to ionic transport nonlinearities which are generated by huge electric fields [12]. These ionic transport nonlinearities are manifested at the memristor edges, where boundary movement speed drops to zero [13]. This change in boundary movement speed is called nonlinear dopant drift and is modeled by introduction of window function given by  $f(x)$  in 2.3. Window function, according to [13], is given by:

$$f(x) = 1 - (2x - 1)^{2p} \quad (2.5)$$

where  $p$  is a positive integer.

This model is used to simulate memristors used in proposed circuit, and the SPICE code for the model is presented in appendix.

## 2.2 Crossbar array

Crossbar array structure has been implemented since 1970s for both memory and logic applications. Simple crossbar array structure consists of a mesh of parallel

and perpendicular wires with a switch at the junction [15]. The switch state can be either open or closed. Memory is stored in the form of state switch, and is extracted by applying a defined voltage on a wire. Logic implementation is also done by presetting the switch state and applying appropriate voltage level [16]. Simple crossbar structure is presented in Fig. 2.3.

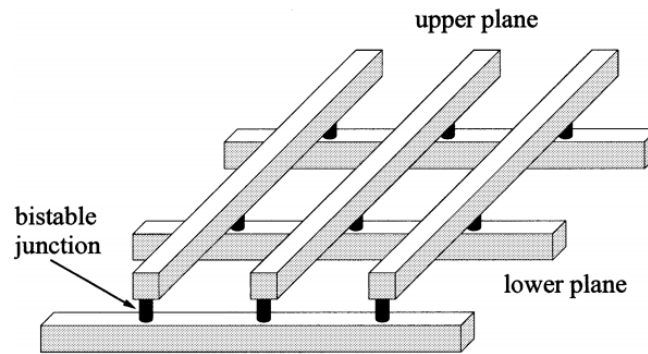
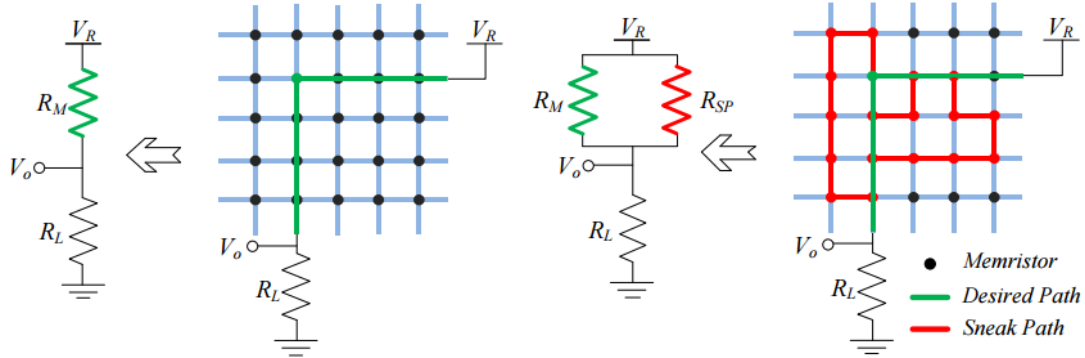

*Figure 2.3: Simple crossbar structure*

Crossbar technologies have been inferior to conventional CMOS memory and logic design in terms of power-efficiency, area and performance [3]. These disadvantages arose primarily due to the inherent characteristics of device implemented as a switch. Application of memristors as switch elements for crossbar architecture has addressed these issues and vast research has been accomplished in the area of memristive crossbar arrays. As CMOS technology is reaching a stagnation point in Moore's law, memristor crossbar memory arrays have been considered as a successor to conventional memory architectures due to high density [17].

Fundamental problem lying on the implementation of such a passive crossbar array (network of wires with a memristor switch) lies in the occurrence of sneak paths [18]. During the read cycle, current starts passing through the desired and undesired memristors. This could lead to potential errors during the

read stage and deteriorate the system accuracy [19]. Furthermore, sneak path increase energy consumption of the overall circuit as the array size increases [20]. For this reason, successful implementation of a memristive crossbar array implementation lies in addressing the issue of sneak paths.



**Figure 2.4: Sneak path representation during the read phase**

Manifold architectures have been proposed to deal with sneak paths and design high-density, accurate and power-efficient crossbar structures. For instance, in [21], hybrid crossbar/CMOS system is presented for memory applications. In this structure, memristive crossbar array is integrated on top of CMOS system without implementing transistors or diodes to avoid sneak paths. Instead, hybrid structure utilizes inherent physical characteristics of the memristor itself. Authors in [21] were able to store the 1600 pixel binary and multilevel images into such an array. Figure 2.5 illustrates the architecture proposed in [21]. Another promising architecture is illustrated in [22]. The architecture combines high-density arrays with transistor isolation for sneak path prevention. Transistor isolate smaller crossbar tiles withing larger memristive crossbar array [22]. Pulse generator sends data to each row in tiles while grounding the others. Row decoders turn on a single row of tile to be accessed during read or write opera-

tions. This design allows for constraining the sneak paths in smaller tiles rather than in the whole crossbar array. Proposed transistor isolated architecture is illustrated in Fig. 2.6.

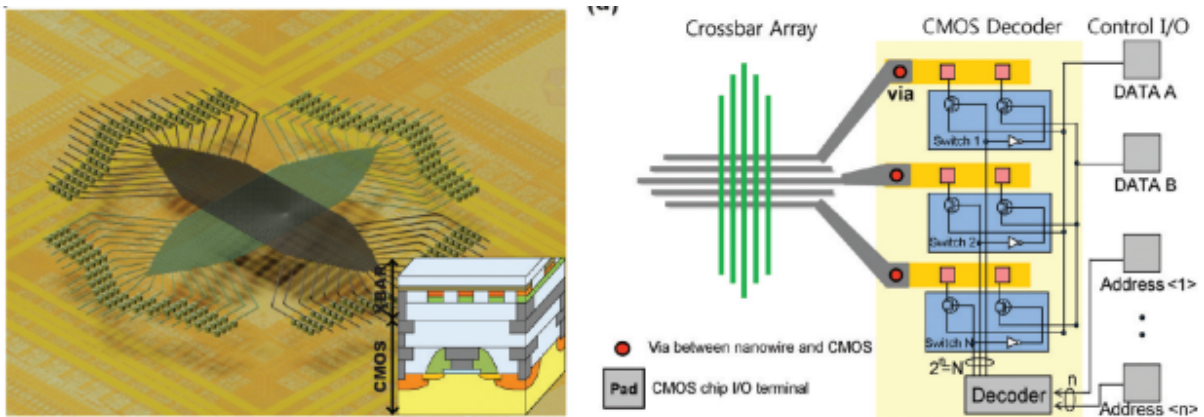

*Figure 2.5: Hybrid memristive crossbar/CMOS system design*

## 2.3 Threshold logic

Threshold logic has found many applications in computing, including microprocessing and bio-inspired processing [23]. Threshold logic gates (TLG) have been considered as a successor to conventional logic gates. The ability to accomplish complex function by using intrinsic properties of threshold logic gates allows for fewer gates and levels compared to standard logic design. Threshold logic design has attracted attention due to potential to implement multiple addition, multiplication, division and sorting [24]. Furthermore, TLG has found applications in modeling neural networks and brain-inspired processes, including learning, adaptive and pattern-recognition systems [25].

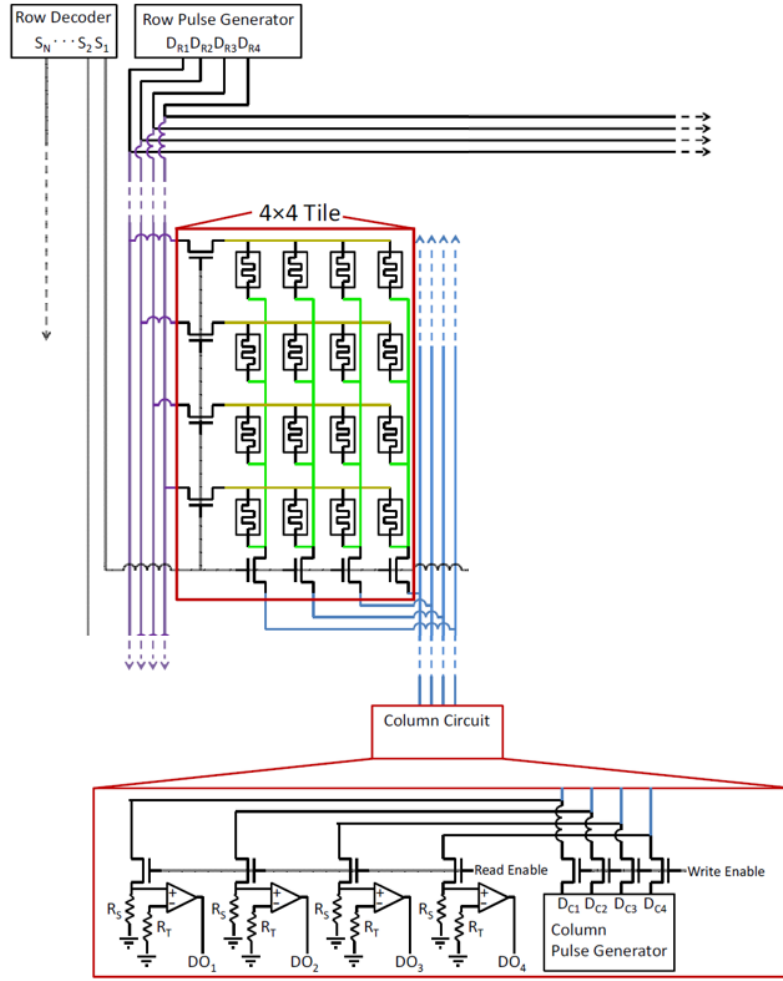

**Figure 2.6: Hybrid tiled memristive crossbar design**

In general, transfer function for a linear threshold logic gate is given by:

$$f(x_1, \dots, x_n) = \begin{cases} 1, & \sum_{i=1}^n w_i x_i \geq T \\ 0, & \text{otherwise} \end{cases} \quad (2.6)$$

where  $x_i$  is the input variable,  $w_i$  is the weight corresponding to input  $i$  and  $T$  is the threshold given by an integer number.

Threshold logic gates using memristors as input weights are discussed in [24], [25], [23]. The most promising design is discussed in [26], which

proposes hybrid memristor/CMOS threshold logic gate. In mentioned configuration, memristors are used as reconfigurable weights, while CMOS inverter is implemented as a threshold logic device. By utilizing the resistive switching ability of memristive devices, weights are assigned and the threshold logic gate configuration may be changed to *NAND*, *NOR* or *XOR* configuration. Figure 2.7 illustrates the threshold logic gate proposed in [26].

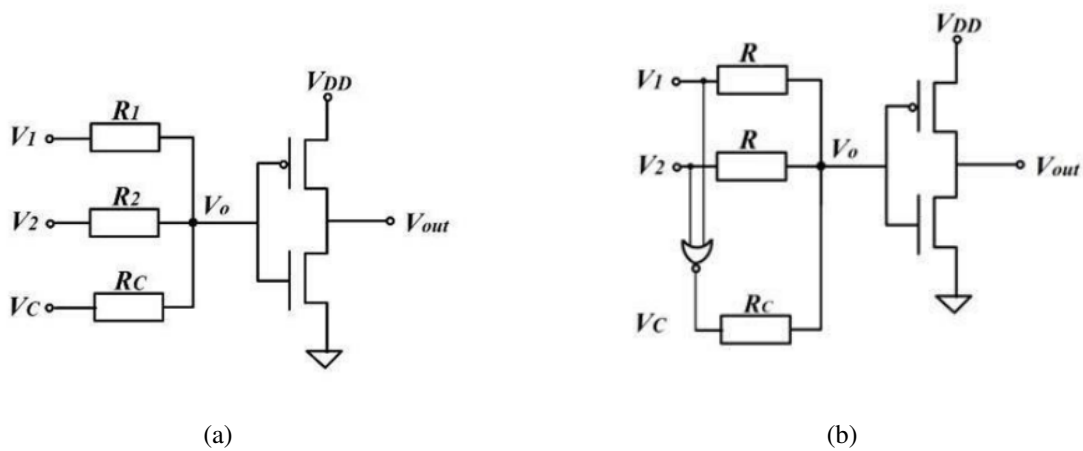

**Figure 2.7: Hybrid memristive/CMOS linear threshold logic gate in (a) *NAND* & *NOR* configuration, (b) *XOR* configuration**

*NAND* and *NOR* configuration is achieved by setting all memristors (two input and one control)  $R_1$ ,  $R_2$ , and  $R_C$  to high resistance state. By setting control voltage  $V_C$  higher than  $0.5V$ , *NOR* functionality is achieved, and *NAND* configuration is achieved by setting  $V_C$  lower than  $0.5V$  [26]. *XOR* functionality is achieved by setting  $V_C$  equal to *NOR* output of two input voltages and setting control memristor  $R_C$  according to:

$$R_C = \begin{cases} R_L, & \text{if } V_C = 1 \\ R_H, & \text{if } V_C = 0 \end{cases} \quad (2.7)$$

where  $R_L$  and  $R_H$  represent low and high resistances respectively.

## 2.4 Content-addressable memory

Content-addressable memory (CAM) is a memory type where the input data is compared to the stored in memory [27]. CAM has a significant advantage in speed, since the comparison is achieved in a single clock cycle. As a result, content-addressable memories have been used in Huffman coding [28], Lempel-Ziv compression [29], and image coding [30]. Although showing fast performance, CAM circuits have a very high power consumption, which limits its applications. Additional disadvantage of using CAMs comes from an increased silicon area [31]. Typical operation of CAM is illustrated in Fig. 2.8. Input to CAM array is provided by searchlines, which is compared to the stored pattern. The output of CAM is provided by matchlines, which is dependent on the similarity between input and stored patterns.



Figure 2.8: Basic content-addressable diagram depicting search and match lines

In order to address the issue of high power consumption and low area scalability, memristors have been proposed as an efficient alternative for transistors in CAMs [32], [33], [34]. Promising design of memristive content-addressable memory cell is proposed in [33], which utilizes two transistors and two mem-

ristors ( $2T - 2M$  configuration) for a single cell. CAM cell proposed in [33] is depicted in Fig. 2.9.

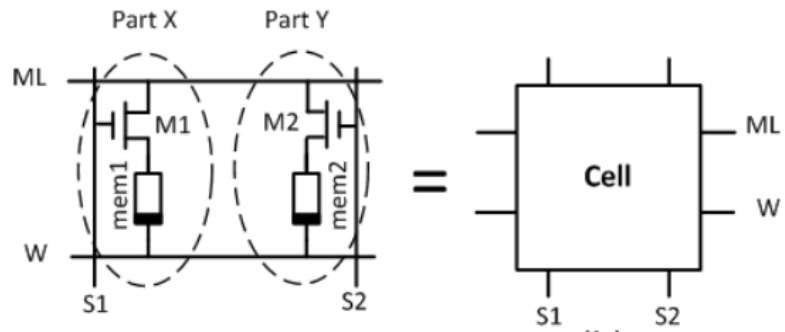

**Figure 2.9: Memristive CAM cell in  $2T-2M$  topology**

## Chapter 3 – Methodology

Extensive research concerning the algorithm implementation is more thoroughly discussed in "Moving Object Detection Using Bit-Plane Slicing" thesis presented by Nazgul Dastanova. Hardware implementation of the algorithm is presented in this thesis. Circuit simulation is achieved via integrating MATLAB and LTSpice [35] as shown in Fig.3.1. Circuit netlist is generated in MATLAB by defining and embedding the necessary elements, models and options. The obtained netlist is then simulated in LTSpice with the exported output. Output from simulation is extracted via using MATLAB for reading.

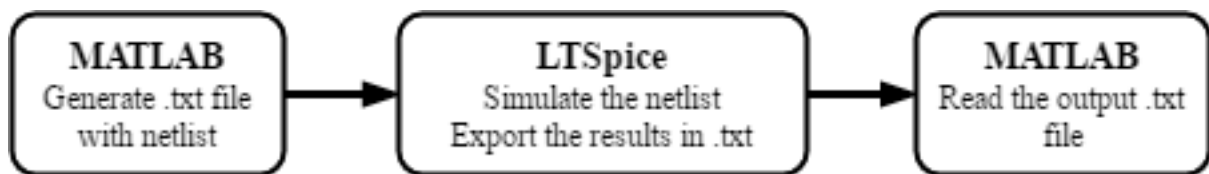

*Figure 3.1: Block diagram of circuit simulation stages*

Hardware block diagram of the proposed circuit is illustrated in Fig. 3.2. Higher order binary bit planes are stored in memristive crossbar arrays. Twelve crossbar arrays are generated to store four higher order bit planes of three consecutive frames in total. Each arrays' columns are integrated with comparator circuit to read the stored bit. Output from comparator circuits from frame #1 and frame #2 are compared using the first group of threshold logic gates, while frames #2 and #3 are compared via another group of threshold logic gates. Grayscale image of moving object is obtained by applying weighted addition of bit planes. Outputs from TLGs are fed to summation circuit, with each compared bit plane having a defined weight. Object's binary image is obtained by thresholding stage. Content-addressable memory is used at the

output stage to store the object detected from the previous pair of consecutive frames and compare it with the one detected from the current pair of consecutive frames.

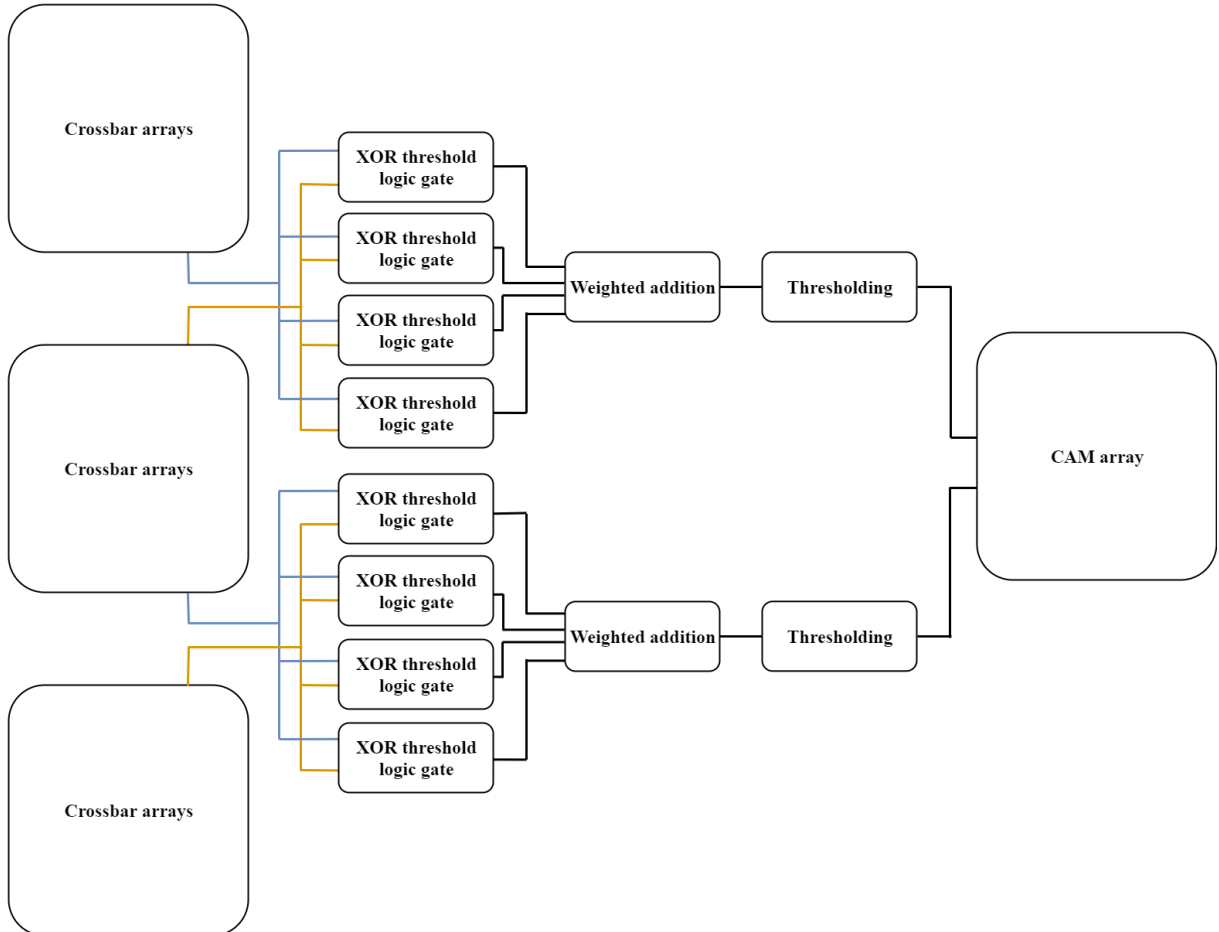
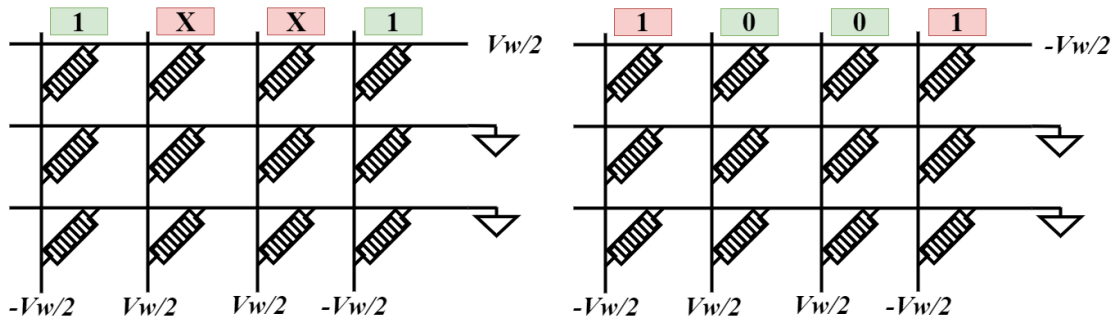

Figure 3.2: Hardware block diagram of the proposed circuit

### 3.1 Memristive crossbar arrays

Bit planes in memristive crossbar arrays are stored in two row-by-row successive write cycles, which are illustrated in Fig. 3.3. Memristors are set applying positive or negative write voltage, which is greater than memristor's threshold voltage ( $V_w > V_{thresh}$ ). During the first cycle, bits of value "1" are written into memristors in the form of low resistance while "0" valued bits remain idle. This

is achieved by applying positive write voltage across memristor terminals,  $V_w/2$  as the row voltage and  $-V_w/2$  as the column voltage. "0" bits are remained idle by applying  $V_w/2$  both as row and column voltage. During the second cycle, bits of value "0" are written in the form of high resistance while already stored "1" bits remain idle.  $-V_w/2$  is applied as the row voltage and  $V_w/2$  as the column voltage resulting in negative write voltage applied across memristor terminals.



**Figure 3.3: Memristor crossbar array write cycle**

Stored bits are read by applying read voltage, which is smaller than threshold voltage in order to avoid resetting the switches ( $V_r < V_{thresh}$ ). Bits are extracted via comparator circuits embedded into crossbar's columns. Comparator circuit comprises load resistor and op-amp along with reference voltage. Depending on memristor's resistance, either "0" or "1" is obtained at the output of comparator circuit in the form of voltage waveform. Potential issue during the read cycle from the crossbar array lies in sneak-path problem. For this reason, conventional row-wise reading becomes error-prone due to decrease of effective resistance by forming a network of parallel memristor. In order to deal with the sneak path problem, memristors are read element-wise after applying read voltage to each row. This is accomplished by introducing an isolating switch between crossbar array and a comparator stage. Memristor crossbar array with the comparator stage is represented in Fig. 3.4

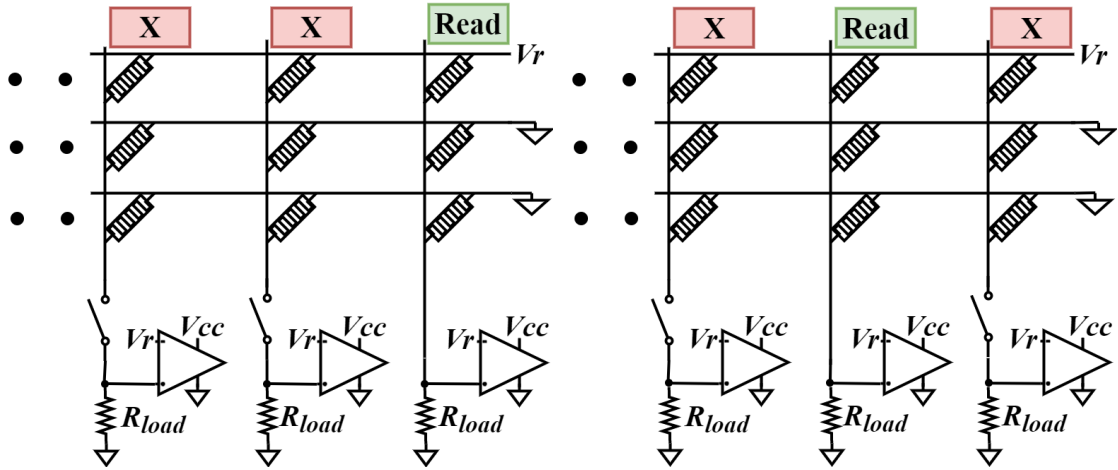

Figure 3.4: Memristor crossbar array read cycle

Comparator stage outputs the stored bits in the form of voltage waveforms. Figure 3.5 illustrates the stored bit sequence  $V_1$  ("1101"), with each bit duration of  $5\mu\text{s}$  and 25% duty cycle.

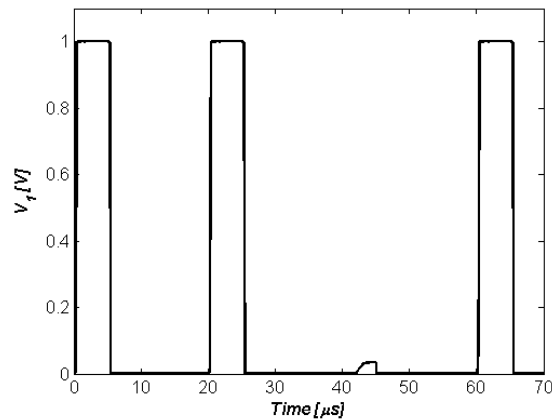

Figure 3.5: Bit sequence "1101" stored and extracted from memristive crossbar array

## 3.2 Threshold logic gates

The next stage comprises memristive threshold logic gate presented in [26]. Bits stored in crossbar arrays are accepted as inputs to threshold logic gate. For instance, crossbar array storing the MSB plane of frame 1 and the one storing

MSB plane of frame 2 are connected to a single threshold logic gate. Logic gate is setup to XOR configuration, which requires the control voltage  $V_c$  to correspond to NOR output of two input voltages. Control resistance is also varied according to control voltage, which is represented in Table 4.1, where  $R_L$  and  $R_H$  correspond to low and high resistances respectively. The output from TLG corresponds to the compared bit value and thus compared bit planes are formed. Crossbar arrays with the integrated TLG are illustrated in Fig. 3.6.

**Table 3.1: Truth table for TLG operation in XOR configuration**

$V_1$	$V_2$	$V_c$	$R_c$	$V_{out}$
0	0	1	$R_L$	0
0	1	0	$R_H$	1
1	0	0	$R_H$	1
1	1	0	$R_H$	0

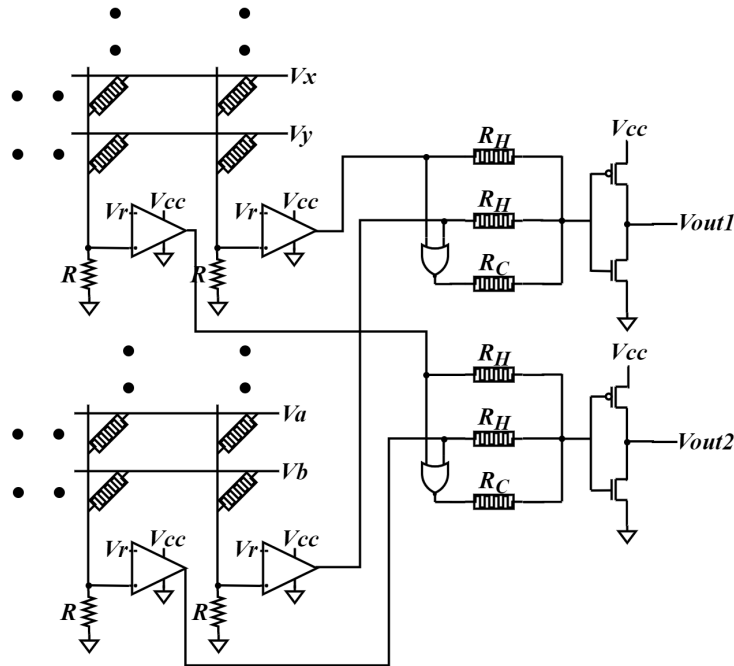

**Figure 3.6: Memristive crossbar arrays integrated with memristive threshold logic gates**

The operation of the memristive threshold logic gate in XOR configuration

is represented in Fig. 3.7. Two input bit sequences  $V_1$  ("1101") and  $V_2$  ("1011") are compared via TLG with the corresponding XOR output. Bit voltage pulses are of  $5\mu s$  duration and 25% duty cycle.

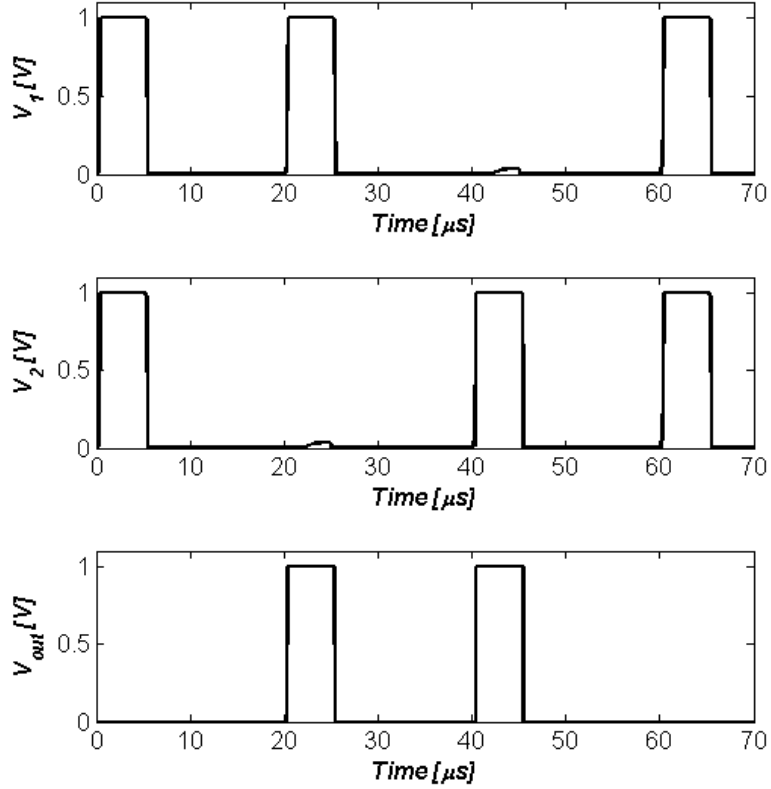

*Figure 3.7: Timing diagram showing the operation of TLG in XOR configuration*

### 3.3 Weighted summation and tresholding circuit

After comparison, bit planes are combined again to obtain a grayscale image. The combination is performed via weighted addition of obtained bit planes, which is implemented in the form of summing operational amplifier in proposed circuit. Weights in the summing operational amplifier are adjusted according to:

$$V_{out} = - \left[ \frac{R_F}{R_{IN1}} V_1 + \frac{R_F}{R_{IN2}} V_2 + \frac{R_F}{R_{IN3}} V_3 + \frac{R_F}{R_{IN4}} V_4 \right], \quad (3.1)$$

where  $V_{out}$  is the output voltage,  $R_F$  is the feedback resistance,  $R_{IN1}$ ,  $R_{IN2}$ ,  $R_{IN3}$ ,  $R_{IN4}$  are input resistances, and  $V_1$ ,  $V_2$ ,  $V_3$ ,  $V_4$  are input voltages respectively.

MSB plane is assigned a weight of 0.5, 6th bit plane - 0.25, 5th bit plane - 0.125, and 4th bit plane - 0.0625. This is achieved by setting  $R_{IN1}$  equal to  $2R_F$ ,  $R_{IN2}$  equal to  $4R_F$ ,  $R_{IN3}$  equal to  $8R_F$ , and  $R_{IN4}$  equal to  $16R_F$ . Weights are assigned with the help of proper memristor ratioing. Since no change in resistance is required in this stage, memristors are configured to have threshold voltage higher than the pulse amplitude  $V_{thresh} > 1V$ . Figure 3.8 illustrates the weighted summing stage circuit setup. Voltage waveforms obtained from weighted summation stage are illustrated in Fig. 3.9.

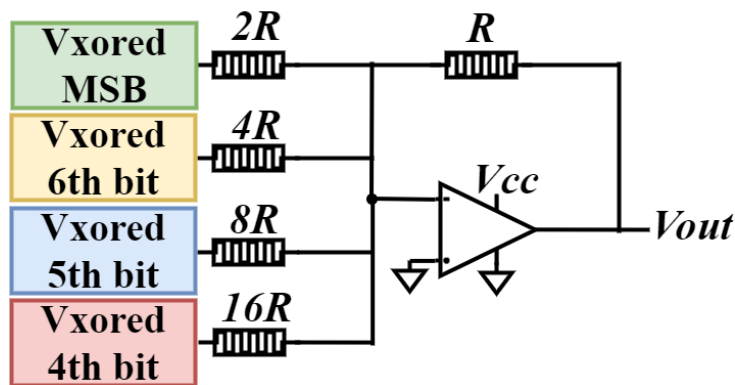

Figure 3.8: Weighted summing circuit stage

The next step according to algorithm includes thresholding of the obtained grayscale image. This is done via comparator circuit embedded after weighted summation stage. Depending on the value of grayscale pixel, either "0" or "1" is produced at the output and final binary image is formed. Thresholding circuit stage is represented in Fig. 3.10. The operation of the thresholding circuit is shown in Fig. 3.11, with the reference voltage  $V_{REF}$  set to  $0.25V$ .

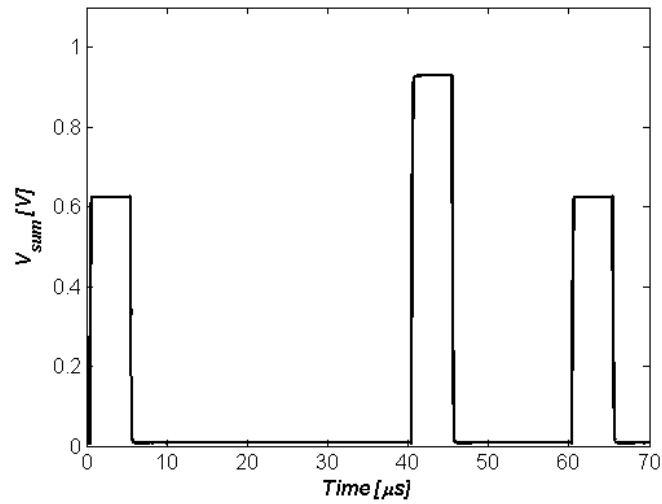

Figure 3.9: Voltage waveforms generated by weighted summing stage

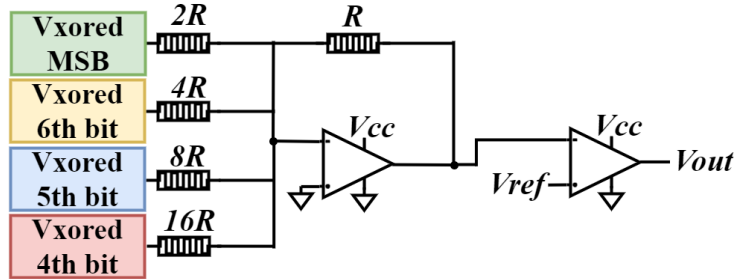
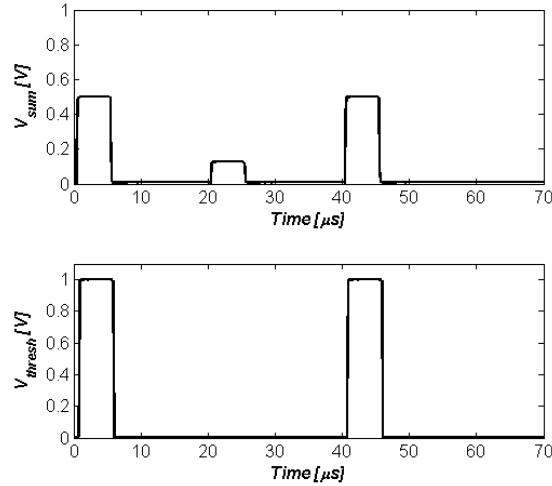

Figure 3.10: Op amp comparator embedded into weighted summing circuit stage

### 3.4 Content-addressable memory

The final stage of proposed circuit consists of memristive content-addressable memory (CAM). Memristive CAM pursuits several purposes in circuit. By observing the difference in discharge operation, it is possible to determine horizontal, vertical or diagonal direction of object movement. In addition to this, CAM array allows for less memory utilization by storing row bits, which are different and leaving the same bits idle. Memristive CAM array or ReCAM (resistive CAM) is based on 2T-2M topology, which utilizes a pair of transistors and memristors. Binary data is stored in the CAM array in the form of high or low resistance. The charge stored in the row capacitor is leaked through a



**Figure 3.11: Timing graph showing the weighted summing generated voltage being thresholded**

mismatched cell, where transistor is ON and memristor has a low resistance opening a path to ground. Binary data is stored in complementary mode since high resistance mismatched cell will not leak charge to ground, while the complementary memristive device with low resistance will. Memristive CAM array circuit is presented in Fig. 3.12. Memristive devices depicted in gray have a "1" stored and high resistance providing no path to ground, while the one depicted in black has a "0" stored and low resistance.

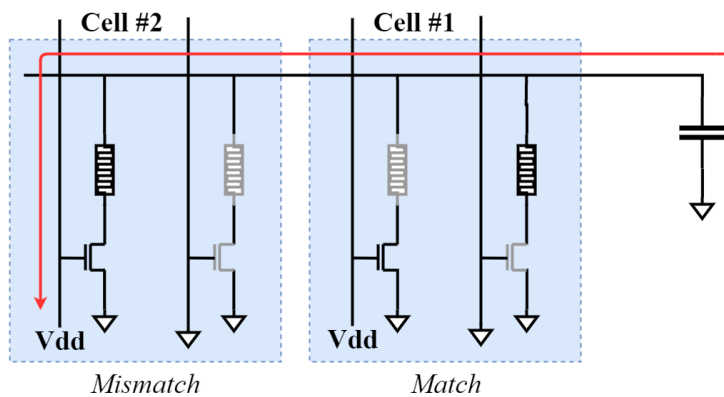

**Figure 3.12: Memristive CAM array circuit in 2T-2M topology with the discharge path in red**

Memristive CAM array operates in two cycles. In the first cycle, output

from the first pair of compared, combined and thresholded frames is written into memristors. Transistor inputs as well row capacitors are disconnected during the write cycle. During the second cycle, output from the second pair of compared, combined and thresholded frames is provided as an input to transistor's gate and a comparison is carried out. Since complementary output are required, thresholding stage is embedded with an inverter to produce complementary outputs. Write and read cycles for CAM array are illustrated in Fig. 3.13 .

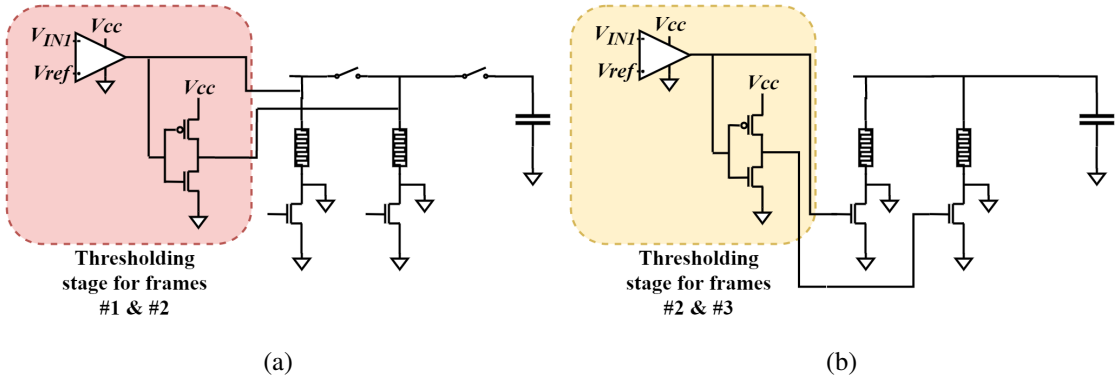

Figure 3.13: Write and read cycles for memristive CAM array. (a) write cycle, (b) read cycle

## Chapter 4 – Results

Simulations were performed in LTSpice environment with the help of netlist generated in MATLAB. CMOS technology is based on *TSMC* technology *BSIM* model with a feature size of  $250nm$ . Memristive device model is based on the model presented in [13], which has a large  $R_{ON}/R_{OFF}$  ratio. The memristor model used in the circuit has some variations in device's threshold voltage  $V_{thresh}$ . In crossbar array and weighted summation circuit, memristive devices have threshold voltage  $V_{thresh}$  higher than  $1V$ . Input memristors for threshold logic gate (different from control memristor) also have a static resistance, while in all other stages memristors' threshold voltage  $V_{thresh}$  is set to be smaller than  $1V$ . The power supply  $V_{CC}$  is kept at  $1V$ , the logic gate output is  $1V$  for logic high and  $0V$  for logic low. Op amp model used in the circuit is based on LM741 model. CAM capacitor has a capacitance of  $100pF$  and an initial charged voltage of  $0.65V$  in order to avoid resetting of memristive devices in CAM.

### 4.1 Crossbar array

Crossbar array performance is observed via storing 4 high order bit planes of three target images, imitating three consequent frames. Images have a size of  $8 \times 8$  pixels and have a distinct difference between each other. Target images along with their higher order bit planes are represented in Fig. 4.1 respectively. Bit sequences are extracted from the comparator circuit in the form of voltage waveforms. Circuit results are exported into MATLAB in order to visualize the extracted sequences. Binary images corresponding to bit planes of three

different frames stored to and extracted from crossbar array are presented in Fig. 4.2.

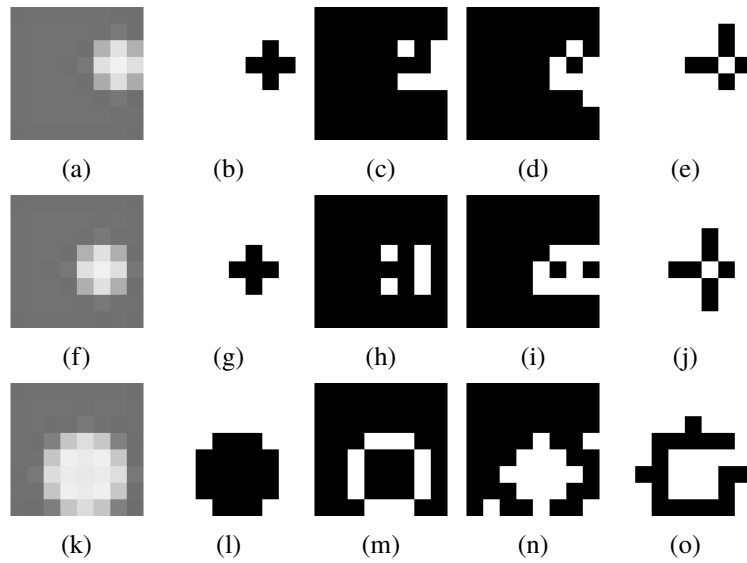

**Figure 4.1:** Original grayscale images for frames #1, #2, and #3 with higher order bit planes. (a),(f),(k) Original grayscale image, (b),(g),(l) MSB plane, (c),(h),(m) 6th bit plane, (d),(i),(n) 5th bit plane, (e),(j),(o) 4th bit plane

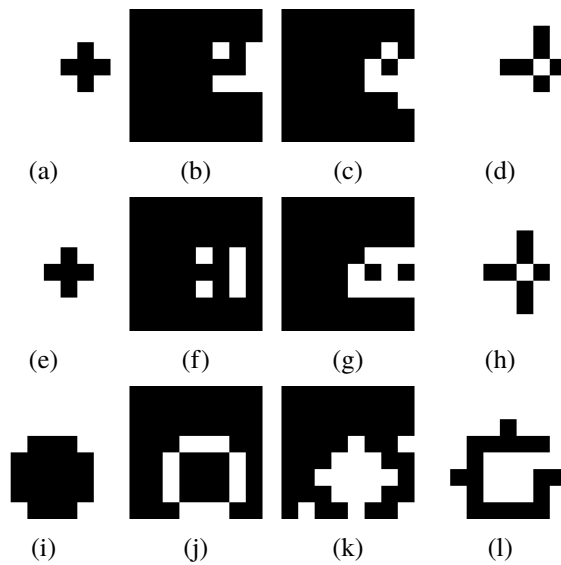

**Figure 4.2:** Bit planes stored to and extracted from crossbar array by using MATLAB. (a)-(d) bit planes of frame #1, (e)-(h) bit planes of frame #2, (i)-(l) bit planes of frame #3

## 4.2 Threshold logic gates

Logic gates compare the corresponding bit planes of first and second pair of consecutive frames. First pair implies frames #1 and #2, while the second pair implies frames #2 and #3. Performance of threshold logic gate is observed by exporting SPICE output into MATLAB. Manually XORed bit planes and TLG output of first and second pair of frames are presented in Fig. 4.3 and Fig. 4.4 respectively. As can be seen from the figures, there are slight deviations between manually obtained XORed bit planes and the ones obtained from circuit. Accuracy aspect is more thoroughly observed in the following chapters, with the dependence on the simulation array size.

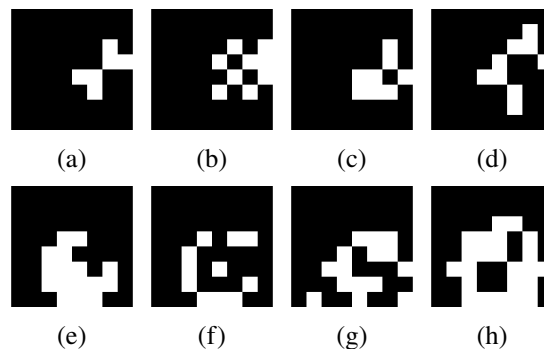

**Figure 4.3:** Manually XORed bit planes of the first (a)-(d) and second (e)-(h) pair of consecutive frames. (a),(e) - MSB, (b),(f) - 6th bit, (c),(g) - 5th bit, (d),(h) - 4th bit

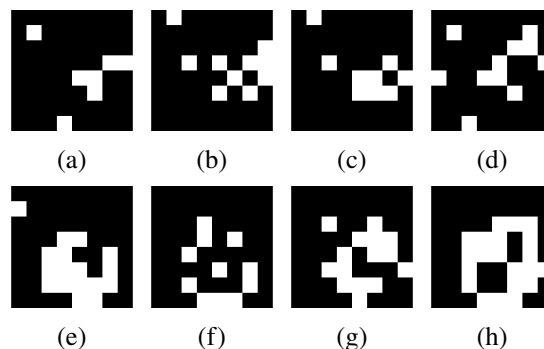
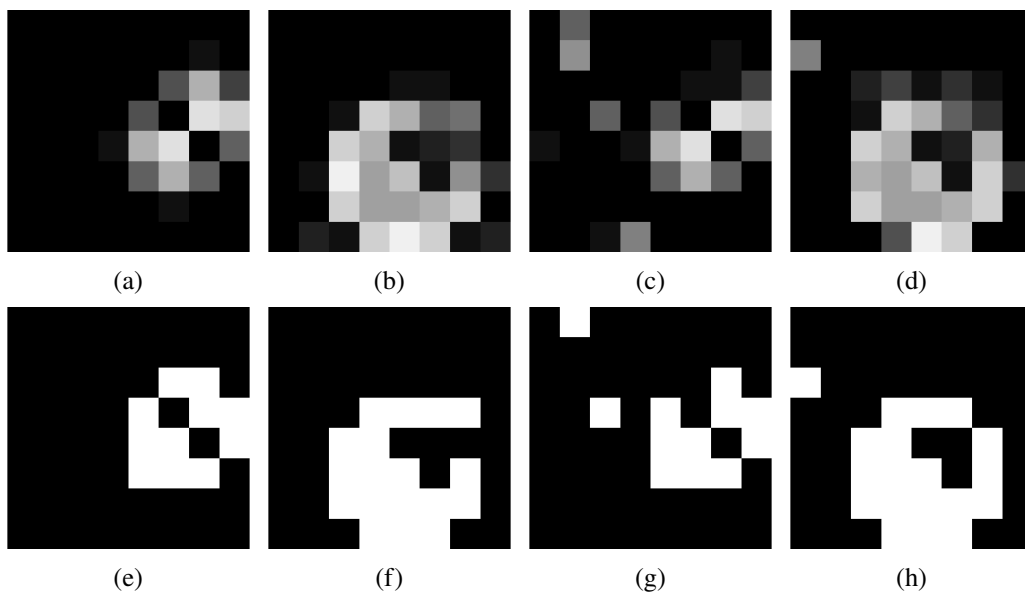

**Figure 4.4:** XORed bit planes of the first (a)-(d) and second (e)-(h) pair of consecutive frames derived from threshold logic gate. (a),(e) - MSB, (b),(f) - 6th bit, (c),(g) - 5th bit, (d),(h) - 4th bit

### 4.3 Weighted summation and thresholding

In order to observe the operation of the weighted summation stage and thresholding stage, results obtained from the algorithm and from the circuit are illustrated. Manual weighted summation is accomplished via multiplying the respective bit planes by the assigned weights and adding them together in MATLAB, while the output from circuit is exported and read via MATLAB. The results are presented in Fig. 4.5.

Thresholding results are obtained by using *im2bw* function in MATLAB with thresholding value of 0.25, while circuit output is exported and read. The circuit's reference voltage  $V_{REF}$  is also set to 0.25V. Thresholded images for both methods are illustrated in Fig. 4.5.



**Figure 4.5:** Grayscale and thresholded images from weighted addition manually (a),(b) and from circuit(c),(d). (a),(c) first pair of frames, (b),(d) second pair of frames

## 4.4 CAM array

Output from the CAM array is formed by observing the discharge curves from matching and mismatching of the thresholded images from the first and second pair of frames. Discharge behaviour is dependent on the number of different bits in each row. Discharge curves from the CAM array for several scenarios are presented in Fig. 4.6. Note that the second row of two images ( $g$ ), ( $h$ ) from Fig. 4.5 are fully matched, first row is mismatched by 1 bit, 3rd row is mismatched by 2 bits, and the 7th row is mismatched by 5 bits.

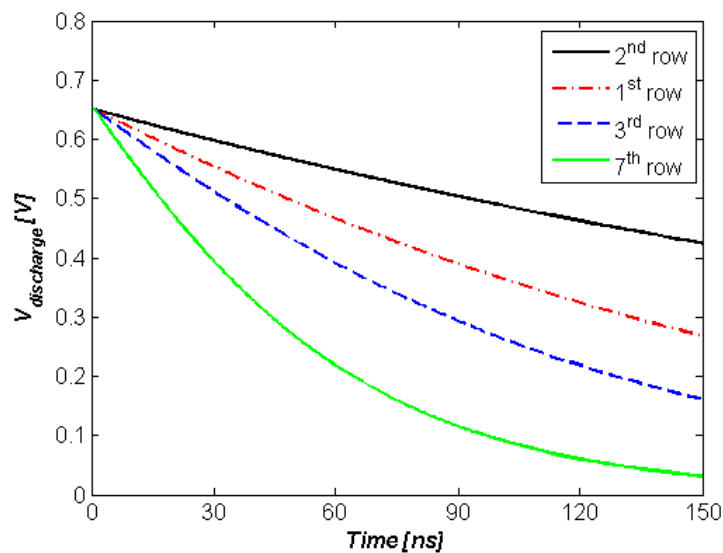
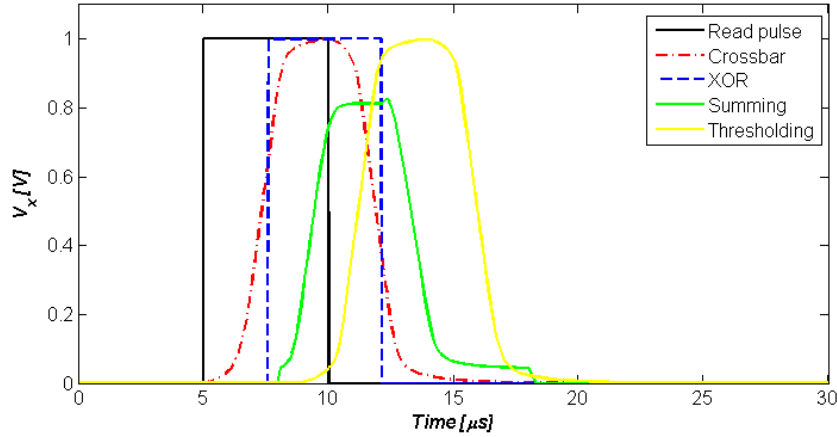

*Figure 4.6: Capacitor voltage discharge curves for match and mismatch cases*

## 4.5 Delay and pulse duration

Due to the implementation of CMOS technologies and op amps, the delay is obtained at the output of each stage. Delay is visualized by analyzing output voltage waveforms after each stage. In addition to signal delays, the effective

duration of pulses is also altered after each stage. This can be seen in Fig 4.7 , where read pulses as well as voltages after each stage are illustrated.



*Figure 4.7: Voltage waveforms obtained after each stage*

*Table 4.1: Delay and changes in pulse duration after each stage*

Stage	Delay ( $\mu s$ )	Pulse duration ( $\mu s$ )
Read	0	5
Crossbar	2.35	4.6
XOR	0.27	4.5
Summing	1.94	3.9
Thesholding	1.82	3.8
Total	6.35	NA

## 4.6 Accuracy, power & area

As can be seen for the XOR stage output, deviations between the circuit output and MATLAB processed images are present. Errors are mostly introduced by TLG stage; however, simulations of larger arrays display better accuracy since incorrectly perceived pixels' number lies in the vicinity of 4-6 pixels for each array. Accuracy, power and area of the proposed circuit for three size configurations are shown in Table 4.2.

In addition to this, temperature sensitivity analysis is accomplished to observe the dependence on temperature variations. Temperature sensitivity analysis shows the acceptable operation of circuit up to  $60^{\circ}\text{C}$  for smaller array size and up to  $80^{\circ}\text{C}$  for bigger array. Dependence of accuracy on temperature is illustrated in Fig. 4.8

**Table 4.2: Accuracy, area and power for different array size**

Array size	Accuracy (%)	Area ( $\mu\text{m}^2$ )	Power ( $\mu\text{W}$ )
4x4	75	1398.2	27.34
8x8	90.6	2703.5	51.63
16x16	97.3	5932.3	107.3

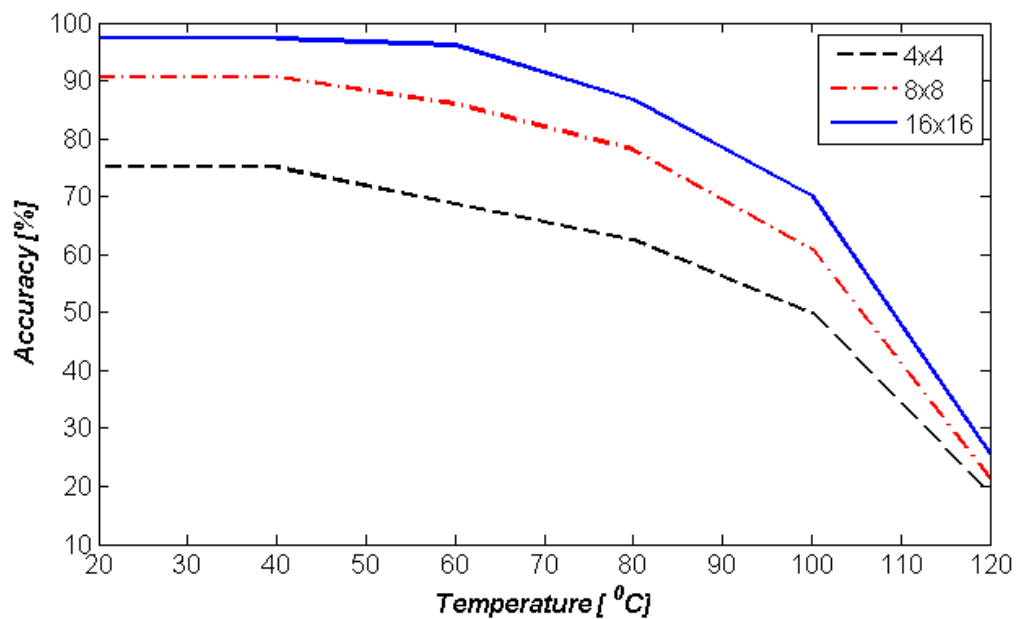

**Figure 4.8: Sensitivity graph showing dependence of accuracy on temperature**

## Chapter 5 – Discussions and conclusions

This thesis focuses on implementation of moving object detection algorithm via incorporation of memristive devices. In the first stage of proposed circuit, extracted binary bit planes of test images are stored in memristive cross-bar arrays in either low or high resistance. Respective bit planes are compared via memristive TLG and combined by weighted addition. Binary image of the detected object is obtained by setting appropriate thresholding level and filtering the noise out. The last stage comprises CAM array, which serves two purposes. First, CAM array is used as a long-term memory which updates when significant difference between two inputs is observed. This allows for more efficient memory utilization and less dissipated power by overwriting only different rows of bits. Second, CAM array allows for analysing capability by observing the capacitor discharge behaviour. Row-wise discharge analysis allows for determining horizontal, vertical or diagonal movement of the object. In addition to this, it is also possible to determine the velocity of the object. If particular rows are discharged with a difference of specific number of bits/pixels, by knowing the time between two input images, it is possible to estimate object's velocity.

As can be seen from the results, very high accuracy is potentially achieved with the increasing array size. The errors are introduced during the comparison stage, which incorporates memristive threshold logic gate. This is ascribed to the resistance of several control memristive devices in TLG, which do not completely tend to change its resistance to produce necessary output. Although, it poses a significant issue for a small array, the number of incorrectly compared pixels is fixed in the range of 4-6 pixels, which still leads to a high accuracy

using a large array size. According to results, proposed circuit is also tolerant to temperature fluctuations and illustrate satisfactory operation up to  $60^{\circ}C$  for small array size and up to  $80^{\circ}C$  for larger array size.

Additional issue lies in the delay and alteration of pulse duration of output signals. This is due to parasitic capacitance in CMOS inverters and slew rate of op amps. It can be seen that the output of the proposed circuit is delayed by  $6.35 \mu s$ , which is detrimental for very high frequency image processing. However, for conventional videos of 30 frames per second, the delay is insignificant. Number of stages stays the same irrespective of array size leading to the same delay time for both small and large pixel frames. This means that high-quality videos of high resolution can potentially be processed with the same delay as the test figures used in thesis.

Power and area calculation results show that proposed circuit has small area and overall power dissipation. In addition to this, crossbar arrangement allows for parallel scalability and high speed operation in parallel. Taking all these features into account, the proposed circuit is a viable candidate for integration with the existing image sensors as a co-processing operator.

Proposed circuit shows satisfactory operation and the results obtained are mostly compliant with algorithm implementation. Improvements could be potentially introduced to several stages of proposed circuit to increase robustness, speed and overall performance. As mentioned before, memristive elements in crossbar array are read row-wise one element at a time. With this approach, sneak path problem is solved; however, the reading time for large images may increase to several seconds for a single frame. Long reading time issue can be tackled by one of the solutions to sneak path problem proposed in [20]. Proposed

circuit can also be improved using a better option for comparator and summing circuits than LM741 op amp. Choice of an operational amplifier with a higher slew rate and smaller power dissipation can significantly boost circuit performance. To further enhance the accuracy, the issue of TLG should be addressed as it is the only stage where the error is introduced at a room temperature operation. Future work for this project would comprise several steps. First step would be to simulate the proposed circuit with the inclusion of tolerance and a small degree of randomness. This will better approximate real-life hardware implementation of circuit and give a better analysis in terms of metrics. Second step would be a simulation of a larger array (e.g. 1024\*768 px) to observe the performance on real-live videos from surveillance cameras, for example. After careful consideration of all these issues, hardware implementation of the proposed circuit can be carried out.

# Bibliography

- [1] M. D. Ventra, Y. V. Pershin, and L. O. Chua, “Circuit elements with memory: Memristors, memcapacitors, and meminductors,” *Proceedings of the IEEE*, vol. 97, no. 10, pp. 1717–1724, Oct 2009.
- [2] K. Eshraghian, K. R. Cho, O. Kavehei, S. K. Kang, D. Abbott, and S. M. S. Kang, “Memristor mos content addressable memory (mcam): Hybrid architecture for future high performance search engines,” *IEEE Transactions on Very Large Scale Integration (VLSI) Systems*, vol. 19, no. 8, pp. 1407–1417, Aug 2011.
- [3] W. Lu, K. H. Kim, T. Chang, and S. Gaba, “Two-terminal resistive switches (memristors) for memory and logic applications,” in *16th Asia and South Pacific Design Automation Conference (ASP-DAC 2011)*, Jan 2011, pp. 217–223.
- [4] E. Lehtonen and M. Laiho, “Stateful implication logic with memristors,” in *2009 IEEE/ACM International Symposium on Nanoscale Architectures*, July 2009, pp. 33–36.
- [5] S. Kvatinsky, A. Kolodny, U. C. Weiser, and E. G. Friedman, “Memristor-based imply logic design procedure,” in *2011 IEEE 29th International Conference on Computer Design (ICCD)*, Oct 2011, pp. 142–147.
- [6] Y. V. Pershin and M. D. Ventra, “Practical approach to programmable analog circuits with memristors,” *IEEE Transactions on Circuits and Systems I: Regular Papers*, vol. 57, no. 8, pp. 1857–1864, Aug 2010.

- [7] S. Shin, K. Kim, and S. M. Kang, "Memristor applications for programmable analog ics," *IEEE Transactions on Nanotechnology*, vol. 10, no. 2, pp. 266–274, March 2011.
- [8] I. E. Ebong and P. Mazumder, "Cmos and memristor-based neural network design for position detection," *Proceedings of the IEEE*, vol. 100, no. 6, pp. 2050–2060, June 2012.
- [9] L. Chua, "Memristor-the missing circuit element," *IEEE Transactions on Circuit Theory*, vol. 18, no. 5, pp. 507–519, Sep 1971.
- [10] T. Prodromakis, B. P. Peh, C. Papavassiliou, and C. Toumazou, "A versatile memristor model with nonlinear dopant kinetics," *IEEE Transactions on Electron Devices*, vol. 58, no. 9, pp. 3099–3105, Sept 2011.
- [11] I. E. Ebong and P. Mazumder, "Cmos and memristor-based neural network design for position detection," *Proceedings of the IEEE*, vol. 100, no. 6, pp. 2050–2060, June 2012.
- [12] D. R. S. D. B. Strukov, G. S. Snider and R. S. Williams, "The missing memristor found,," in *Nature*, vol. 453, 2016, pp. 80–83.
- [13] D. B. Z. Biolek and V. Biolkova, "Spice model of memristor with nonlinear dopant drift," *Radioengineering*, vol. 18, no. 2, pp. 210–214, 2009.
- [14] A. G. Radwan, M. A. Zidan, and K. N. Salama, "Hp memristor mathematical model for periodic signals and dc," in *2010 53rd IEEE International Midwest Symposium on Circuits and Systems*, Aug 2010, pp. 861–864.

- [15] T. Raja and S. Mourad, “Digital logic implementation in memristor-based crossbars - a tutorial,” in *2010 Fifth IEEE International Symposium on Electronic Design, Test Applications*, Jan 2010, pp. 303–309.
- [16] J. Shah, M. Barangi, and P. Mazumder, “Memristor crossbar memory for hybrid ultra low power hearing aid speech processor,” in *2013 13th IEEE International Conference on Nanotechnology (IEEE-NANO 2013)*, Aug 2013, pp. 83–86.
- [17] R. Rosezin, E. Linn, L. Nielen, C. Kugeler, R. Bruchhaus, and R. Waser, “Integrated complementary resistive switches for passive high-density nanocrossbar arrays,” *IEEE Electron Device Letters*, vol. 32, no. 2, pp. 191–193, Feb 2011.
- [18] C. M. Jung, J. M. Choi, and K. S. Min, “Two-step write scheme for reducing sneak-path leakage in complementary memristor array,” *IEEE Transactions on Nanotechnology*, vol. 11, no. 3, pp. 611–618, May 2012.
- [19] S. Kannan, J. Rajendran, R. Karri, and O. Sinanoglu, “Sneak-path testing of crossbar-based nonvolatile random access memories,” *IEEE Transactions on Nanotechnology*, vol. 12, no. 3, pp. 413–426, May 2013.
- [20] R. Naous, M. A. Zidan, A. Sultan-Salem, and K. N. Salama, “Memristor based crossbar memory array sneak path estimation,” in *2014 14th International Workshop on Cellular Nanoscale Networks and their Applications (CNNA)*, July 2014, pp. 1–2.
- [21] D. W. J. M. C.-A. T. H. N. S. Kuk-Hwan Kim, Siddharth Gaba and W. Lu, “A functional hybrid memristor crossbar-array/cmos system for data storage

- and neuromorphic applications,” *Nano Lett.*, vol. 12, no. 1, pp. 389–395, Dec 2012.
- [22] C. Yakopcic, T. M. Taha, and R. Hasan, “Hybrid crossbar architecture for a memristor based memory,” in *NAECON 2014 - IEEE National Aerospace and Electronics Conference*, June 2014, pp. 237–242.
- [23] L. Xie, “Hybrid threshold-boolean logic mapped on memristor crossbar,” in *2016 12th Conference on Ph.D. Research in Microelectronics and Electronics (PRIME)*, June 2016, pp. 1–4.
- [24] M. Teimoori, A. Ahmadi, S. Alirezaee, S. V. A. D. Makki, and M. Ahmadi, “A novel memristor based integrate-and-fire neuron implementation using material implication logic,” in *2015 IEEE 28th Canadian Conference on Electrical and Computer Engineering (CCECE)*, May 2015, pp. 1176–1179.
- [25] C. B. Dara, T. Haniotakis, and S. Tragoudas, “Low power and high speed current-mode memristor-based tlgs,” in *2013 IEEE International Symposium on Defect and Fault Tolerance in VLSI and Nanotechnology Systems (DFTS)*, Oct 2013, pp. 89–94.
- [26] A. K. Maan and A. P. James, “Voltage controlled memristor threshold logic gate,” in *Circuits & Systems (IEEE APCCAS 2016), 2016 IEEE Asia Pacific Conference on*, Nov 2016.
- [27] I. Arsovski and A. Sheikholeslami, “A mismatch-dependent power allocation technique for match-line sensing in content-addressable memories,”

- IEEE Journal of Solid-State Circuits*, vol. 38, no. 11, pp. 1958–1966, Nov 2003.
- [28] M. Ishizaki, T. Kumaki, Y. Kouno, T. Koide, H. J. Mattausch, Y. Kuroda, T. Gyoten, H. Noda, K. Dosaka, K. Arimoto, and K. Saito, “Huffman encoding architecture with self-optimizing performance and multiple cam-match utilization,” in *TENCON 2006 - 2006 IEEE Region 10 Conference*, Nov 2006, pp. 1–4.
- [29] R. Samanta and R. N. Mahapatra, “An enhanced cam architecture to accelerate lzw compression algorithm,” in *20th International Conference on VLSI Design held jointly with 6th International Conference on Embedded Systems (VLSID’07)*, Jan 2007, pp. 824–829.
- [30] T. Kumaki, Y. Kuroda, T. Koide, H. J. Mattausch, H. Noda, K. Dosaka, K. Arimoto, and K. Saito, “Cam-based vlsi architecture for huffman coding with real-time optimization of the code word table [image coding example],” in *2005 IEEE International Symposium on Circuits and Systems*, May 2005, pp. 5202–5205 Vol. 5.
- [31] K. Pagiamtzis and A. Sheikholeslami, “Content-addressable memory (cam) circuits and architectures: a tutorial and survey,” *IEEE Journal of Solid-State Circuits*, vol. 41, no. 3, pp. 712–727, March 2006.
- [32] W. Chen, X. Yang, and F. Z. Wang, “Memristor content addressable memory,” in *2014 IEEE/ACM International Symposium on Nanoscale Architectures (NANOARCH)*, July 2014, pp. 83–87.
- [33] P. Junsangsri, F. Lombardi, and J. Han, “A memristor-based tcam (ternary

- content addressable memory) cell,” in *2014 IEEE/ACM International Symposium on Nanoscale Architectures (NANOARCH)*, July 2014, pp. 1–6.
- [34] K. Eshraghian, K. R. Cho, O. Kavehei, S. K. Kang, D. Abbott, and S. M. S. Kang, “Memristor mos content addressable memory (mcam): Hybrid architecture for future high performance search engines,” *IEEE Transactions on Very Large Scale Integration (VLSI) Systems*, vol. 19, no. 8, pp. 1407–1417, Aug 2011.
- [35] LTspice and D. Models, “Linear technology,” 2013.

# Appendix

## Appendix A - SPICE memristor model

```

*****
* MS - Modified S model;
*****
.SUBCKT MSmodel A B
*Modified S-model
.params RON=0.1K ROFF=100K VTH=0.7 K=-200e7 a=400 RINI=19K
.params DELTAR='ROFF-RON' XINI='(ROFF-RINI)/DELTAR'
.func FS(x)={1/a*log((1+exp(a*(x+0.5)))/
+           (1+exp(a*(x-0.5))))}
.param Y0='xini-0.5+1/a*log(1-exp(-a*xini))
+           -1/a*log(1-exp(-a*(1-xini)))'
.func thr(x,th)='if(x<=-th,x+th,if(x>=th,x-th,0))'

*State Equation
GY 0 Y VALUE={1m*k*thr(v(A,B),Vth)/
+           (ROFF-DELTAR*FS(Y0+V(Y)))}
CY Y 0 1m
RY Y 0 1T
.IC v(Y)=0

*Port Equation
GM A B VALUE={v(A,B)/(ROFF-DELTAR*FS(Y0+V(Y)))}
Rp A B 1T

.ENDS MSmodel

```

## Appendix B - MATLAB code (without CAM)

```

%% MATLAB code to generate memristor CAM array netlist

clc,clear all;
% initialization of array size
rows = 8;
cols = 8;

% initialization of cells to store grayscale images &
% bit planes
N = 3;
T=cell(N,9);
xored=cell(N-1,4);
final=cell(N-1,1);
for i=1:N;
    I=imread(strcat(num2str(i),'.jpg'));
    bbb= rgb2gray(I);
    bbb=imresize(bbb,[rows cols]);
    T{i,1}=bbb;
    filename=strcat('figure',num2str(i),'.jpg');
    imwrite(bbb,filename);
    for j=2:9
        T{i,j}=mod(floor(T{i,1}/2^(j-2)),2);
        T{i,j}=im2double(T{i,j}*255);
    end
end

% formation of XORed bit planes to compare with circuit output
for kk=5:8
    for ll=1:N-1
        xored{ll,kk}=xor(T{ll,kk+1},T{ll+1,kk+1});
    end
end

% formation of grayscale image to compare with circuit output
for tr=1:N-1
    final{tr,1}=0.5*xored{tr,8}+0.25*xored{tr,7}+...
        0.125*xored{tr,6}+0.0625*xored{tr,5};
end

%%

%creation of txt file to save the generated netlist
ID = fopen('spice.txt','wt');

%comments in netlist for clarification
fprintf(ID,['* This is a SPICE code generator\n',...
'* Bit planes of frame #1 are stored in crossbar arrays #1-4\n',...
'* Bit planes of frame #2 are stored in crossbar arrays #5-8\n',...
'* Bit planes of frame #3 are stored in crossbar arrays #9-12\n',...
'* Bits are read from all crossbar arrays simultaneously\n',...
'* Respective bit planes of consequent frames are XORed\n',...
'* E.g. XOR(frame #1 bit plane 8, frame #2 bit plane 8)\n',...
'* Vp, Vn - voltages to set the memristors into ON/OFF states\n',...
'* Vwrite, Vread - voltages to control switches for write and read cycle\n',...
'* Vr - input voltage for reading (< than memristor Vth)\n',...
'* Vrefcross - reference voltage for crossbar comparator circuit\n',...
'* Vrefthresh - reference voltage for thresholding stage\n',...
'* Vccomp, Vnncomp - +ve & -ve supply voltages for crossbar comparator op amp\n',...
'* Vccsum, Vnnsum - +ve & -ve supply voltages for summing op amp\n',...
'* Vdd - CMOS supply voltage\n',...
'* Voutread - voltage corresponding to bit values stored in crossbar array\n',...
'* Vxored - voltage corresponding XORED value of bits\n',...
'* Vinvsum - voltage corresponding to weighted addition of XORED bits\n',...
'* Vtotal - voltage corresponding to thresholded output\n\n\n']);

%inclusion of required libraries and models
fprintf(ID,['.model SW SW(Vt=0.5 Roff=1T)\n','.lib MScam.sub\n',...1
'.include tsmc_model_250nm.txt\n','.lib MS.sub\n',...
'.lib MSnew.sub\n',...
'.lib C:\PROGRA~2\LTC\LTSPIC~1\lib\cmp\standard.mos\n',...
'.model NMOS NMOS\n','.model PMOS PMOS\n','.lib UniversalOpamps2.sub\n',...
'.lib BEE215\ua741.lib\n\n']);

%adjusting parameters to increase simulation speed
fprintf(ID,['.options gmin=1e-9\n',...
'.options abstol=1e-9\n',...

```

```

'.options reltol=0.003\n',...
'.options cshunt=1e-16\n\n']);

%signal generation
fprintf(ID,['Vp Vp 0 2\n','Vn Vn 0 -7\n','Vrefcross Vrefcross 0 0.5\n',...
'Vr Vr 0 1\n','Vdd Vdd 0 1\n','Vcccomp Vcccomp 0 3.01\n',...
'Vrefthresh Vrefthresh 0 0.2\n',...
'Vnncomp Vnncomp 0 -1.995\n','Vccsum Vccsum 0 2.05\n',...
'Vnsum Vnsum 0 -3.01\n\n',...
'Vwrite Vwrite 0 PULSE (0 1 0 in 1n 9.2u 10u 1)\n']);

fprintf(ID,['Vcontrol+ Vcontrol+ 0 0.2\n',...
'Vcontrol- Vcontrol- 0 -0.2\n',...
'Vdd Vdd 0 1\n']);

for yt = 1:cols
fprintf(ID,'VwriteXOR%d VwriteXOR%d 0 PULSE(0 1 %du 1n 1n 5u %du) \n',...
[yt,yt,(yt)*5-5+0.01,5*cols]);
fprintf(ID,'VreadXOR%d VreadXOR%d 0 PULSE (0 1 %du 1n 1n 5u %du)\n',...
[yt,yt,10+(yt)*5-5+0.01,5*cols]);
end

for i=1:rows
fprintf(ID,'Vread%d Vread%d 0 PULSE(0 1 %du 1n 1n %du %du 1)\n',...
[i,i,10+(i-1)*5*cols, 5*cols, 5*cols]);
end

for y=1:cols
fprintf(ID,'Vreadcol%d Vreadcol%d 0 PULSE(0 1 %du 1n 1n 5u %du)\n',...
[y,y, 10+(y-1)*5,5*cols]);
end

fprintf(ID,'\n');
% ARRAY A

%generate crossbar array for higher order bit planes of 3 frames
%4 higher order bit planes * 3 frames = 12 crossbar arrays
for tq=1:12
if tq>0 && tq<5
A = T{1,10-tq};
elseif tq>4 && tq<9
A = T{2,10-tq+4};
else
A = T{3,10-tq+8};
end
%generation of switches connecting input to rows and cells to each other
for hh = 1:rows
for k=1:cols
if (mod(k+(hh-1)*2*cols,2*cols)==1)
fprintf(ID,'S%d Vr N%03d Vread%d 0 SW\n',...
[2*cols*(rows+1)*(tq-1)+k+(hh-1)*2*cols,...
(tq-1)*cols*(rows+2)+k+(hh-1)*cols,hh]);
else
fprintf (ID,'S%d N%03d N%03d Vread%d 0 SW\n',...
[2*cols*(rows+1)*(tq-1)+2*k-1+(hh-1)*2*cols,...
cols*(rows+2)*(tq-1)+k-1+(hh-1)*cols,...
cols*(rows+2)*(tq-1)+k+(hh-1)*cols,hh]);
end
end
end

%generation of switches for memristor setting
for ii = 1:rows
for ll = 1:cols
if A(ii,ll)==1
fprintf(ID,'S%d Vp N%03d Vwrite 0 SW\n',...
[2*cols*(rows+1)*(tq-1)+2*ll+(ii-1)*2*cols,...
cols*(rows+2)*(tq-1)+ll+(ii-1)*cols]);
elseif A(ii,ll)==0
fprintf(ID,'S%d Vn N%03d Vwrite 0 SW\n',...
[2*cols*(rows+1)*(tq-1)+2*ll+(ii-1)*2*cols,...
cols*(rows+2)*(tq-1)+ll+(ii-1)*cols]);
end
end
end

for gg = 1:cols
fprintf(ID,'S%d 0 N%03d Vwrite 0 SW\n',...
[2*cols*(rows+1)*(tq-1)+2*rows*cols+gg, ...
cols*(rows+2)*(tq-1)+rows*cols+gg]);
end

%generation of memristors in crossbar array
for jj = 1:rows

```

```

    for rr = 1:cols
        fprintf(ID,'XU%d N%03d N%03d MScammodel MScammodel\n',...
            [cols*(rows+1)*(tq-1)+rr+(jj-1)*cols,...
            cols*(rows+2)*(tq-1)+rows*cols+rr,...
            cols*(rows+2)*(tq-1)+rr+(jj-1)*cols]);
    end
end

%generation of switches for comparator circuit
for tt = 1:cols
    fprintf(ID,'S%d N%03d N%03d Vreadcol%d 0 SW\n',...
        [2*cols*(rows+1)*(tq-1)+cols*(2*rows+1)+tt,...
        cols*(rows+2)*(tq-1)+rows*cols+tt,...
        cols*(rows+2)*(tq-1)+cols*(rows+1)+tt,tt]);
end

%generation of load resistors for comparator
for oo=1:cols
    fprintf(ID,'R%d N%03d 0 57k\n',...
        [oo+cols*(tq-1),cols*(rows+2)*(tq-1)+cols*(rows+1)+oo]);
end

%generation of op-amps for comparator
for pp=1:cols
    fprintf(ID,'XU%d N%03d Vrefcross Vcccomp Vnncomp Voutread%d%d ua741\n',...
        [cols*(rows+1)*(tq-1)+rows*cols+pp,...
        cols*(rows+2)*(tq-1)+cols*(rows+1)+pp,tq,pp]);
end
%
%%% For XOR gates
if tq<5
    for qe=1:cols
        fprintf(ID,'XU1000%d Voutread%d%d Vinpvtinv%d%d MSmodel MSmodel\n',...
            [(qe-1)*3+1+(tq-1)*3*cols, tq,qe,tq,qe]);
        fprintf(ID,'XU1000%d Voutread%d%d Vinpvtinv%d%d MSmodel MSmodel\n',...
            [(qe-1)*3+2+(tq-1)*3*cols, tq,qe,tq,qe]);
        fprintf(ID,'XU1000%d Voutread%d%d Vinpvtinv%d%d MSnewmodel MSnewmodel\n',...
            [(qe)*3+1+(tq-1)*3*cols, tq,qe,tq,qe]);
    end
end
if tq>4 && tq<9
    for qe=1:cols
        fprintf(ID,'XU1000%d Voutread%d%d Vinpvtinv%d%d MSmodel MSmodel\n',...
            [(qe-1)*3+1+(tq-1)*3*cols, tq,qe,tq,qe]);
        fprintf(ID,'XU1000%d Voutread%d%d Vinpvtinv%d%d MSmodel MSmodel\n',...
            [(qe-1)*3+2+(tq-1)*3*cols, tq,qe,tq,qe]);
        fprintf(ID,'XU1000%d Voutread%d%d Vinpvtinv%d%d MSnewmodel MSnewmodel\n',...
            [(qe)*3+1+(tq-1)*3*cols, tq,qe,tq,qe]);
    end
end

%%% For summing opamps
if tq<5
    for yt=1:cols
        fprintf(ID,'Rin%d%d Vxored%d%d Vinpvt1%d %dk\n',...
            [tq,yt,tq,yt,yt,2^(tq)]);
        if tq==1
            fprintf(ID,'Rfeed%d%d Vinpvt1%d Vsum1%d 1k\n',...
                [tq,yt,yt,yt]);
            fprintf(ID,'XU%d 0 Vinpvt1%d Vccsum Vnnsum Vsum1%d ua741\n',...
                [rows*(cols+1)*12+yt,yt,yt]);
            fprintf(ID,'Rinvin%d%d Vsum1%d Vinpvtphase1%d 10k\n',...
                [tq,yt,yt,yt]);
            fprintf(ID,'Rfeedphase%d%d Vinpvtphase1%d Vinvsum1%d 10k\n',...
                [tq,yt,yt,yt]);
            fprintf(ID,'XU%d 0 Vinpvtphase1%d Vcccomp Vnncomp Vinvsum1%d ua741\n',...
                [rows*(cols+1)*12+2*cols+yt, yt,yt]);
            fprintf(ID,'XU%d Vinvsum1%d Vrefthresh Vcccomp Vnncomp Vtotal1%d ua741\n',...
                [rows*(cols+1)*12+3*cols+yt,yt,yt]);
            fprintf(ID,'M%d%d Vdd Vtotal1%d Vinvttotal1%d Vdd CMOS1 l=250n w=2500n\n',...
                [tq,yt,yt,yt]);
            fprintf(ID,'M%d%d Vinvttotal1%d Vtotal1%d 0 0 CMOSN l=250n w=2500n \n',...
                [tq,yt+cols,yt,yt]);
        end
    end
end
if tq>4 && tq<9
    for yt=1:cols
        fprintf(ID,'Rin%d%d Vxored%d%d Vinpvt2%d %dk\n',...
            [tq,yt,tq,yt,yt,2^(tq-4)]);
        if tq==5
            fprintf(ID,'Rfeed%d%d Vinpvt2%d Vsum2%d 1k\n',...
                [tq-3,yt,yt,yt]);
        end
    end
end

```

```

fprintf(ID,'XU%d 0 Vinut2%d Vccsum Vnnsum Vsum2%d ua741\n',...
[rows*(cols+1)*12+cols+yt,yt,yt]);
fprintf(ID,'Rinvin%d%d Vsum2%d Vinutphase2%d 10k\n',...
[tq-3,yt,yt,yt]);
fprintf(ID,'Rfeedphase%d%d Vinutphase2%d Vinvsum2%d 10k\n',...
[tq-3,yt,yt,yt]);
fprintf(ID,'XU%d 0 Vinutphase2%d Vcccomp Vnncomp Vinvsum2%d ua741\n',...
[rows*(cols+1)*12+4*cols+yt, yt,yt]);
fprintf(ID,'XU%d Vinvsum2%d Vrefthresh Vcccomp Vnncomp Vtotal2%d ua741\n',...
[rows*(cols+1)*12+5*cols+yt,yt,yt]);
fprintf(ID,'M%d%d Vdd Vtotal2%d Vinvtotal2%d Vdd CMOSP l=250n w=2500n\n',...
[tq-3,yt,yt,yt]);
fprintf(ID,'M%d%d Vinvtotal2%d Vtotal2%d 0 0 CMOSN l=250n w=2500n \n',...
[tq-3,yt+cols,yt,yt]);
end
end
end
end
end
fprintf(ID, '.tran 0 %du 10u uic\n',[10+rows*cols*5+2]);
fprintf(ID,['.backanno\n','end\n']);

```

## Appendix C - MATLAB code for CAM array

```

FID = fopen('CAM.txt','wt');
%netlist generation
fprintf(FID,'* This is a SPICE code generator for CAM\n');
%include libraries and models
fprintf(FID,['.model SW SW(Vt=0.5 Roff=1T)\n',' .lib MS.sub\n',...
'.include tsmc_model_250nm.txt\n',...
'.lib C:\\PROGRA~2\\LTC\\LTSPIC~1\\lib\\cmp\\standard.mos\n',...
'.model NMOS NMOS\n\n']);
%adjusting parameters to increase simulation speed
fprintf(FID,['.options gmin=1e-9\n',...
'.options abstol=1e-9\n',...
'.options reltol=0.003\n',...
'.options cshunt=1e-16\n\n']);
%generate signals
fprintf(FID,['Vcc Vcc 0 1\n','Vp Vp 0 1\n','Vn Vn 0 -1\n',...
'Vwritecam Vwritecam 0 PULSE(0 1 0 1n 1n 3u 10u 1)\n',...
'Vreadcam Vreadcam 0 PULSE(0 1 10u 1n 1n 3u 10u 1)\n\n']);
for re=1:rows
    fprintf(FID,'C%d Cap%d 0 100p IC=0.65\n',...
        [re,re]);
end
frame12 = thresha;
frame23 = threshb;
for eq=1:rows
    for tq=1:cols
        if tq==1
            fprintf(FID,'S%d%d Cap%d Memin%d%d Vreadcam 0 SW\n',...
                [eq,tq,eq,eq,tq]);
            fprintf(FID,'S%d%d Memin%d%d Memin%d%d Vreadcam 0 SW\n',...
                [eq,tq+3,eq,tq,eq,tq+1]);
        else
            fprintf(FID,'S%d%d Memin%d%d Memin%d%d Vreadcam 0 SW\n',...
                [eq,(tq-1)*6+1,eq,(tq-1)*2,eq,(tq-1)*2+1]);
            fprintf(FID,'S%d%d Memin%d%d Memin%d%d Vreadcam 0 SW\n',...
                [eq,(tq-1)*6+4,eq,(tq-1)*2+1,eq,tq*2]);
        end
        fprintf(FID,'S%d%d Memout%d%d 0 Vwritecam 0 SW\n',...
            [eq,(tq-1)*6+3,eq,(tq-1)*2+1]);
        fprintf(FID,'S%d%d Memout%d%d 0 Vwritecam 0 SW\n',...
            [eq,tq*6,eq,tq*2]);
        fprintf(FID,'XU%d%d Memin%d%d Memout%d%d MSmodel MSmodel\n',...
            [eq,(tq-1)*2+1,eq,(tq-1)*2+1,eq,(tq-1)*2+1]);
        fprintf(FID,'XU%d%d Memin%d%d Memout%d%d MSmodel MSmodel\n',...
            [eq,tq*2,eq,tq*2,eq,tq*2]);
        if frame12(eq,tq)==1
            fprintf(FID,'S%d%d Memin%d%d Vp Vwritecam 0 SW\n',...
                [eq,(tq-1)*6+2,eq,(tq-1)*2+1]);
            fprintf(FID,'S%d%d Memin%d%d Vn Vwritecam 0 SW\n',...
                [eq,(tq-1)*6+5,eq,tq*2]);
        else
            fprintf(FID,'S%d%d Memin%d%d Vn Vwritecam 0 SW\n',...
                [eq,(tq-1)*6+2,eq,(tq-1)*2+1]);
            fprintf(FID,'S%d%d Memin%d%d Vp Vwritecam 0 SW\n',...
                [eq,(tq-1)*6+5,eq,tq*2]);
        end
        if frame23(eq,tq)==1
            fprintf(FID,'M%d%d Memout%d%d Vreadcam 0 0 CMOSN l=250n w=2500n\n',...
                [eq,(tq-1)*2+1,eq,(tq-1)*2+1]);
            fprintf(FID,'M%d%d Memout%d%d 0 0 CMOSN l=250n w=2500n\n',...
                [eq,tq*2,eq,tq*2]);
        else
            fprintf(FID,'M%d%d Memout%d%d 0 0 CMOSN l=250n w=2500n\n',...
                [eq,(tq-1)*2+1,eq,(tq-1)*2+1]);
            fprintf(FID,'M%d%d Memout%d%d Vreadcam 0 0 CMOSN l=250n w=2500n\n',...
                [eq,tq*2,eq,tq*2]);
        end
    end
end
end
fprintf(FID,['.tran 0 10.1u 10u uic\n',' .backanno\n',' .end\n']);

```

# Appendix D - SPICE netlist generation code (without CAM)

```
* This is a SPICE code generator
* Higher order bit planes of frame #1 are stored in crossbar arrays #1-4 during the write cycle
* Higher order bit planes of frame #2 are stored in crossbar arrays #5-8 during the write cycle
* Higher order bit planes of frame #3 are stored in crossbar arrays #9-12 during the write cycle
* Bits are read during the read cycle from all crossbar arrays simultaneously
* Respective bit planes of consequent frames are XORed to get the desired output
* E.g. XOR(frame #1 bit plane 8, frame #2 bit plane 8)

* Vp, Vn - voltages to set the memristors into ON and OFF states respectively
* Vwrite, Vread - voltages to control crossbar switches for write and read cycle respectively
* Vr - input voltage for reading (< than memristor Vth)
* Vrefcross - reference voltage for crossbar comparator circuit
* Vrefthresh - reference voltage for thresholding stage
* Vcccomp, Vnncomp - +ve & -ve supply voltages for crossbar comparator op amp
* Vccsum, Vnnsum - +ve & -ve supply voltages for summing op amp
* Vdd - CMOS supply voltage
* Voutread - voltage corresponding to bit values stored in crossbar array
* Vxored - voltage corresponding XORED value of bits
* Vinvsum - voltage corresponding to weighted addition of XORED bits
* Vtotal - voltage corresponding to thresholded output

.model SW SW(Vt=0.5 Roff=1T)
.lib MScam.sub
.include tsmc_model_250nm.txt
.lib MS.sub
.lib MSnew.sub
.lib C:\PROGRA~2\LTC\LTSPIC~1\lib\cmp\standard.mos
.model NMOS NMOS
.model PMOS PMOS
.lib UniversalOpamps2.sub
.lib BEE215\ua741.lib

.options gmin=1e-9
.options abstol=1e-9
.options reltol=0.003
.options cshunt=1e-16

Vp Vp 0 2
Vn Vn 0 -7
Vrefcross Vrefcross 0 0.5
Vr Vr 0 1
Vdd Vdd 0 1
Vcccomp Vcccomp 0 3.01
Vrefthresh Vrefthresh 0 0.2
Vnncomp Vnncomp 0 -1.995
Vccsum Vccsum 0 2.05
Vnnsum Vnnsum 0 -3.01

Vwrite Vwrite 0 PULSE(0 1 0 1n 1n 9.2u 10u 1)
Vread1 Vread1 0 PULSE(0 1 10u 1n 1n 40u 40u 1)
Vread2 Vread2 0 PULSE(0 1 50u 1n 1n 40u 40u 1)
Vread3 Vread3 0 PULSE(0 1 90u 1n 1n 40u 40u 1)
Vread4 Vread4 0 PULSE(0 1 130u 1n 1n 40u 40u 1)
Vread5 Vread5 0 PULSE(0 1 170u 1n 1n 40u 40u 1)
Vread6 Vread6 0 PULSE(0 1 210u 1n 1n 40u 40u 1)
Vread7 Vread7 0 PULSE(0 1 250u 1n 1n 40u 40u 1)
Vread8 Vread8 0 PULSE(0 1 290u 1n 1n 40u 40u 1)
Vreadcol1 Vreadcol1 0 PULSE(0 1 10u 1n 1n 5u 40u)
Vreadcol2 Vreadcol2 0 PULSE(0 1 15u 1n 1n 5u 40u)
Vreadcol3 Vreadcol3 0 PULSE(0 1 20u 1n 1n 5u 40u)
Vreadcol4 Vreadcol4 0 PULSE(0 1 25u 1n 1n 5u 40u)
Vreadcol5 Vreadcol5 0 PULSE(0 1 30u 1n 1n 5u 40u)
Vreadcol6 Vreadcol6 0 PULSE(0 1 35u 1n 1n 5u 40u)
Vreadcol7 Vreadcol7 0 PULSE(0 1 40u 1n 1n 5u 40u)
Vreadcol8 Vreadcol8 0 PULSE(0 1 45u 1n 1n 5u 40u)

S1 Vr N001 Vread1 0 SW
S3 N001 N002 Vread1 0 SW
S5 N002 N003 Vread1 0 SW
S7 N003 N004 Vread1 0 SW
S9 N004 N005 Vread1 0 SW
```

S11 N005 N006 Vread1 0 SW  
S13 N006 N007 Vread1 0 SW  
S15 N007 N008 Vread1 0 SW  
S17 Vr N009 Vread2 0 SW  
S19 N009 N010 Vread2 0 SW  
S21 N010 N011 Vread2 0 SW  
S23 N011 N012 Vread2 0 SW  
S25 N012 N013 Vread2 0 SW  
S27 N013 N014 Vread2 0 SW  
S29 N014 N015 Vread2 0 SW  
S31 N015 N016 Vread2 0 SW  
S33 Vr N017 Vread3 0 SW  
S35 N017 N018 Vread3 0 SW  
S37 N018 N019 Vread3 0 SW  
S39 N019 N020 Vread3 0 SW  
S41 N020 N021 Vread3 0 SW  
S43 N021 N022 Vread3 0 SW  
S45 N022 N023 Vread3 0 SW  
S47 N023 N024 Vread3 0 SW  
S49 Vr N025 Vread4 0 SW  
S51 N025 N026 Vread4 0 SW  
S53 N026 N027 Vread4 0 SW  
S55 N027 N028 Vread4 0 SW  
S57 N028 N029 Vread4 0 SW  
S59 N029 N030 Vread4 0 SW  
S61 N030 N031 Vread4 0 SW  
S63 N031 N032 Vread4 0 SW  
S65 Vr N033 Vread5 0 SW  
S67 N033 N034 Vread5 0 SW  
S69 N034 N035 Vread5 0 SW  
S71 N035 N036 Vread5 0 SW  
S73 N036 N037 Vread5 0 SW  
S75 N037 N038 Vread5 0 SW  
S77 N038 N039 Vread5 0 SW  
S79 N039 N040 Vread5 0 SW  
S81 Vr N041 Vread6 0 SW  
S83 N041 N042 Vread6 0 SW  
S85 N042 N043 Vread6 0 SW  
S87 N043 N044 Vread6 0 SW  
S89 N044 N045 Vread6 0 SW  
S91 N045 N046 Vread6 0 SW  
S93 N046 N047 Vread6 0 SW  
S95 N047 N048 Vread6 0 SW  
S97 Vr N049 Vread7 0 SW  
S99 N049 N050 Vread7 0 SW  
S101 N050 N051 Vread7 0 SW  
S103 N051 N052 Vread7 0 SW  
S105 N052 N053 Vread7 0 SW  
S107 N053 N054 Vread7 0 SW  
S109 N054 N055 Vread7 0 SW  
S111 N055 N056 Vread7 0 SW  
S113 Vr N057 Vread8 0 SW  
S115 N057 N058 Vread8 0 SW  
S117 N058 N059 Vread8 0 SW  
S119 N059 N060 Vread8 0 SW  
S121 N060 N061 Vread8 0 SW  
S123 N061 N062 Vread8 0 SW  
S125 N062 N063 Vread8 0 SW  
S127 N063 N064 Vread8 0 SW  
S2 Vp N001 Vwrite 0 SW  
S4 Vp N002 Vwrite 0 SW  
S6 Vp N003 Vwrite 0 SW  
S8 Vp N004 Vwrite 0 SW  
S10 Vp N005 Vwrite 0 SW  
S12 Vp N006 Vwrite 0 SW  
S14 Vp N007 Vwrite 0 SW  
S16 Vp N008 Vwrite 0 SW  
S18 Vp N009 Vwrite 0 SW  
S20 Vp N010 Vwrite 0 SW  
S22 Vp N011 Vwrite 0 SW  
S24 Vp N012 Vwrite 0 SW  
S26 Vp N013 Vwrite 0 SW  
S28 Vp N014 Vwrite 0 SW  
S30 Vp N015 Vwrite 0 SW  
S32 Vp N016 Vwrite 0 SW  
S34 Vp N017 Vwrite 0 SW  
S36 Vp N018 Vwrite 0 SW  
S38 Vp N019 Vwrite 0 SW  
S40 Vp N020 Vwrite 0 SW  
S42 Vp N021 Vwrite 0 SW  
S44 Vp N022 Vwrite 0 SW  
S46 Vn N023 Vwrite 0 SW  
S48 Vp N024 Vwrite 0 SW  
S50 Vp N025 Vwrite 0 SW

```

S52 Vp N026 Vwrite 0 SW
S54 Vp N027 Vwrite 0 SW
S56 Vp N028 Vwrite 0 SW
S58 Vp N029 Vwrite 0 SW
S60 Vn N030 Vwrite 0 SW
S62 Vn N031 Vwrite 0 SW
S64 Vn N032 Vwrite 0 SW
S66 Vp N033 Vwrite 0 SW
S68 Vp N034 Vwrite 0 SW
S70 Vp N035 Vwrite 0 SW
S72 Vp N036 Vwrite 0 SW
S74 Vp N037 Vwrite 0 SW
S76 Vp N038 Vwrite 0 SW
S78 Vn N039 Vwrite 0 SW
S80 Vp N040 Vwrite 0 SW
S82 Vp N041 Vwrite 0 SW
S84 Vp N042 Vwrite 0 SW
S86 Vp N043 Vwrite 0 SW
S88 Vp N044 Vwrite 0 SW
S90 Vp N045 Vwrite 0 SW
S92 Vp N046 Vwrite 0 SW
S94 Vp N047 Vwrite 0 SW
S96 Vp N048 Vwrite 0 SW
S98 Vp N049 Vwrite 0 SW
S100 Vp N050 Vwrite 0 SW
S102 Vp N051 Vwrite 0 SW
S104 Vp N052 Vwrite 0 SW
S106 Vp N053 Vwrite 0 SW
S108 Vp N054 Vwrite 0 SW
S110 Vp N055 Vwrite 0 SW
S112 Vp N056 Vwrite 0 SW
S114 Vp N057 Vwrite 0 SW
S116 Vp N058 Vwrite 0 SW
S118 Vp N059 Vwrite 0 SW
S120 Vp N060 Vwrite 0 SW
S122 Vp N061 Vwrite 0 SW
S124 Vp N062 Vwrite 0 SW
S126 Vp N063 Vwrite 0 SW
S128 Vp N064 Vwrite 0 SW
S129 0 N065 Vwrite 0 SW
S130 0 N066 Vwrite 0 SW
S131 0 N067 Vwrite 0 SW
S132 0 N068 Vwrite 0 SW
S133 0 N069 Vwrite 0 SW
S134 0 N070 Vwrite 0 SW
S135 0 N071 Vwrite 0 SW
S136 0 N072 Vwrite 0 SW
XU1 N065 N001 MScammodel MScammodel
XU2 N066 N002 MScammodel MScammodel
XU3 N067 N003 MScammodel MScammodel
XU4 N068 N004 MScammodel MScammodel
XU5 N069 N005 MScammodel MScammodel
XU6 N070 N006 MScammodel MScammodel
XU7 N071 N007 MScammodel MScammodel
XU8 N072 N008 MScammodel MScammodel
XU9 N065 N009 MScammodel MScammodel
XU10 N066 N010 MScammodel MScammodel
XU11 N067 N011 MScammodel MScammodel
XU12 N068 N012 MScammodel MScammodel
XU13 N069 N013 MScammodel MScammodel
XU14 N070 N014 MScammodel MScammodel
XU15 N071 N015 MScammodel MScammodel
XU16 N072 N016 MScammodel MScammodel
XU17 N065 N017 MScammodel MScammodel
XU18 N066 N018 MScammodel MScammodel
XU19 N067 N019 MScammodel MScammodel
XU20 N068 N020 MScammodel MScammodel
XU21 N069 N021 MScammodel MScammodel
XU22 N070 N022 MScammodel MScammodel
XU23 N071 N023 MScammodel MScammodel
XU24 N072 N024 MScammodel MScammodel
XU25 N065 N025 MScammodel MScammodel
XU26 N066 N026 MScammodel MScammodel
XU27 N067 N027 MScammodel MScammodel
XU28 N068 N028 MScammodel MScammodel
XU29 N069 N029 MScammodel MScammodel
XU30 N070 N030 MScammodel MScammodel
XU31 N071 N031 MScammodel MScammodel
XU32 N072 N032 MScammodel MScammodel
XU33 N065 N033 MScammodel MScammodel
XU34 N066 N034 MScammodel MScammodel
XU35 N067 N035 MScammodel MScammodel
XU36 N068 N036 MScammodel MScammodel
XU37 N069 N037 MScammodel MScammodel

```

```

XU38 N070 N038 MScammodel MScammodel
XU39 N071 N039 MScammodel MScammodel
XU40 N072 N040 MScammodel MScammodel
XU41 N065 N041 MScammodel MScammodel
XU42 N066 N042 MScammodel MScammodel
XU43 N067 N043 MScammodel MScammodel
XU44 N068 N044 MScammodel MScammodel
XU45 N069 N045 MScammodel MScammodel
XU46 N070 N046 MScammodel MScammodel
XU47 N071 N047 MScammodel MScammodel
XU48 N072 N048 MScammodel MScammodel
XU49 N065 N049 MScammodel MScammodel
XU50 N066 N050 MScammodel MScammodel
XU51 N067 N051 MScammodel MScammodel
XU52 N068 N052 MScammodel MScammodel
XU53 N069 N053 MScammodel MScammodel
XU54 N070 N054 MScammodel MScammodel
XU55 N071 N055 MScammodel MScammodel
XU56 N072 N056 MScammodel MScammodel
XU57 N065 N057 MScammodel MScammodel
XU58 N066 N058 MScammodel MScammodel
XU59 N067 N059 MScammodel MScammodel
XU60 N068 N060 MScammodel MScammodel
XU61 N069 N061 MScammodel MScammodel
XU62 N070 N062 MScammodel MScammodel
XU63 N071 N063 MScammodel MScammodel
XU64 N072 N064 MScammodel MScammodel
S137 N065 N073 Vreadcol1 0 SW
S138 N066 N074 Vreadcol2 0 SW
S139 N067 N075 Vreadcol3 0 SW
S140 N068 N076 Vreadcol4 0 SW
S141 N069 N077 Vreadcol5 0 SW
S142 N070 N078 Vreadcol6 0 SW
S143 N071 N079 Vreadcol7 0 SW
S144 N072 N080 Vreadcol8 0 SW
R1 N073 0 57k
R2 N074 0 57k
R3 N075 0 57k
R4 N076 0 57k
R5 N077 0 57k
R6 N078 0 57k
R7 N079 0 57k
R8 N080 0 57k
XU65 N073 Vrefcross Vcccomp Vnncomp Voutread11 ua741
XU66 N074 Vrefcross Vcccomp Vnncomp Voutread12 ua741
XU67 N075 Vrefcross Vcccomp Vnncomp Voutread13 ua741
XU68 N076 Vrefcross Vcccomp Vnncomp Voutread14 ua741
XU69 N077 Vrefcross Vcccomp Vnncomp Voutread15 ua741
XU70 N078 Vrefcross Vcccomp Vnncomp Voutread16 ua741
XU71 N079 Vrefcross Vcccomp Vnncomp Voutread17 ua741
XU72 N080 Vrefcross Vcccomp Vnncomp Voutread18 ua741
A11 Voutread11 Voutread51 0 0 0 0 Vxored11 0 XOR td=0.27u
A12 Voutread12 Voutread52 0 0 0 0 Vxored12 0 XOR td=0.27u
A13 Voutread13 Voutread53 0 0 0 0 Vxored13 0 XOR td=0.27u
A14 Voutread14 Voutread54 0 0 0 0 Vxored14 0 XOR td=0.27u
A15 Voutread15 Voutread55 0 0 0 0 Vxored15 0 XOR td=0.27u
A16 Voutread16 Voutread56 0 0 0 0 Vxored16 0 XOR td=0.27u
A17 Voutread17 Voutread57 0 0 0 0 Vxored17 0 XOR td=0.27u
A18 Voutread18 Voutread58 0 0 0 0 Vxored18 0 XOR td=0.27u
Rin11 Vxored11 Vininput11 2k
Rfeed11 Vininput11 Vsum11 1k
XU865 0 Vininput11 Vccsum Vnnsum Vsum11 ua741
Rinvin11 Vsum11 Vininputphase11 10k
Rfeedphase11 Vininputphase11 Vinvsum11 10k
XU881 0 Vininputphase11 Vcccomp Vnncomp Vinvsum11 ua741
XU889 Vinvsum11 Vrefthresh Vcccomp Vnncomp Vtotal11 ua741
M11 Vdd Vtotal11 Vinvtotal11 Vdd CMOS l=250n w=2500n
M19 Vinvtotal11 Vtotal11 0 0 CMOS l=250n w=2500n
Rin12 Vxored12 Vininput12 2k
Rfeed12 Vininput12 Vsum12 1k
XU866 0 Vininput12 Vccsum Vnnsum Vsum12 ua741
Rinvin12 Vsum12 Vininputphase12 10k
Rfeedphase12 Vininputphase12 Vinvsum12 10k
XU882 0 Vininputphase12 Vcccomp Vnncomp Vinvsum12 ua741
XU890 Vinvsum12 Vrefthresh Vcccomp Vnncomp Vtotal12 ua741
M12 Vdd Vtotal12 Vinvtotal12 Vdd CMOS l=250n w=2500n
M110 Vinvtotal12 Vtotal12 0 0 CMOS l=250n w=2500n
Rin13 Vxored13 Vininput13 2k
Rfeed13 Vininput13 Vsum13 1k
XU867 0 Vininput13 Vccsum Vnnsum Vsum13 ua741
Rinvin13 Vsum13 Vininputphase13 10k
Rfeedphase13 Vininputphase13 Vinvsum13 10k
XU883 0 Vininputphase13 Vcccomp Vnncomp Vinvsum13 ua741

```

```

XU891 Vinvsu13 Vrefthresh Vcccomp Vnncomp Vtotal13 ua741
M13 Vdd Vtotal13 Vinvtotal13 Vdd CMOSP l=250n w=2500n
M111 Vinvtotal13 Vtotal13 0 0 CMOSN l=250n w=2500n
Rin14 Vxored14 Vinput14 2k
Rfeed14 Vinput14 Vsum14 1k
XU868 0 Vinput14 Vccsum Vnnsum Vsum14 ua741
Rinvin14 Vsum14 Vinputphase14 10k
Rfeedphase14 Vinputphase14 Vinvsu14 10k
XU884 0 Vinputphase14 Vcccomp Vnncomp Vinvsu14 ua741
XU892 Vinvsu14 Vrefthresh Vcccomp Vnncomp Vtotal14 ua741
M14 Vdd Vtotal14 Vinvtotal14 Vdd CMOSP l=250n w=2500n
M112 Vinvtotal14 Vtotal14 0 0 CMOSN l=250n w=2500n
Rin15 Vxored15 Vinput15 2k
Rfeed15 Vinput15 Vsum15 1k
XU869 0 Vinput15 Vccsum Vnnsum Vsum15 ua741
Rinvin15 Vsum15 Vinputphase15 10k
Rfeedphase15 Vinputphase15 Vinvsu15 10k
XU885 0 Vinputphase15 Vcccomp Vnncomp Vinvsu15 ua741
XU893 Vinvsu15 Vrefthresh Vcccomp Vnncomp Vtotal15 ua741
M15 Vdd Vtotal15 Vinvtotal15 Vdd CMOSP l=250n w=2500n
M113 Vinvtotal15 Vtotal15 0 0 CMOSN l=250n w=2500n
Rin16 Vxored16 Vinput16 2k
Rfeed16 Vinput16 Vsum16 1k
XU870 0 Vinput16 Vccsum Vnnsum Vsum16 ua741
Rinvin16 Vsum16 Vinputphase16 10k
Rfeedphase16 Vinputphase16 Vinvsu16 10k
XU886 0 Vinputphase16 Vcccomp Vnncomp Vinvsu16 ua741
XU894 Vinvsu16 Vrefthresh Vcccomp Vnncomp Vtotal16 ua741
M16 Vdd Vtotal16 Vinvtotal16 Vdd CMOSP l=250n w=2500n
M114 Vinvtotal16 Vtotal16 0 0 CMOSN l=250n w=2500n
Rin17 Vxored17 Vinput17 2k
Rfeed17 Vinput17 Vsum17 1k
XU871 0 Vinput17 Vccsum Vnnsum Vsum17 ua741
Rinvin17 Vsum17 Vinputphase17 10k
Rfeedphase17 Vinputphase17 Vinvsu17 10k
XU887 0 Vinputphase17 Vcccomp Vnncomp Vinvsu17 ua741
XU895 Vinvsu17 Vrefthresh Vcccomp Vnncomp Vtotal17 ua741
M17 Vdd Vtotal17 Vinvtotal17 Vdd CMOSP l=250n w=2500n
M115 Vinvtotal17 Vtotal17 0 0 CMOSN l=250n w=2500n
Rin18 Vxored18 Vinput18 2k
Rfeed18 Vinput18 Vsum18 1k
XU872 0 Vinput18 Vccsum Vnnsum Vsum18 ua741
Rinvin18 Vsum18 Vinputphase18 10k
Rfeedphase18 Vinputphase18 Vinvsu18 10k
XU888 0 Vinputphase18 Vcccomp Vnncomp Vinvsu18 ua741
XU896 Vinvsu18 Vrefthresh Vcccomp Vnncomp Vtotal18 ua741
M18 Vdd Vtotal18 Vinvtotal18 Vdd CMOSP l=250n w=2500n
M116 Vinvtotal18 Vtotal18 0 0 CMOSN l=250n w=2500n
S145 Vr N081 Vread1 0 SW
S147 N081 N082 Vread1 0 SW
S149 N082 N083 Vread1 0 SW
S151 N083 N084 Vread1 0 SW
S153 N084 N085 Vread1 0 SW
S155 N085 N086 Vread1 0 SW
S157 N086 N087 Vread1 0 SW
S159 N087 N088 Vread1 0 SW
S161 Vr N089 Vread2 0 SW
S163 N089 N090 Vread2 0 SW
S165 N090 N091 Vread2 0 SW
S167 N091 N092 Vread2 0 SW
S169 N092 N093 Vread2 0 SW
S171 N093 N094 Vread2 0 SW
S173 N094 N095 Vread2 0 SW
S175 N095 N096 Vread2 0 SW
S177 Vr N097 Vread3 0 SW
S179 N097 N098 Vread3 0 SW
S181 N098 N099 Vread3 0 SW
S183 N099 N100 Vread3 0 SW
S185 N100 N101 Vread3 0 SW
S187 N101 N102 Vread3 0 SW
S189 N102 N103 Vread3 0 SW
S191 N103 N104 Vread3 0 SW
S193 Vr N105 Vread4 0 SW
S195 N105 N106 Vread4 0 SW
S197 N106 N107 Vread4 0 SW
S199 N107 N108 Vread4 0 SW
S201 N108 N109 Vread4 0 SW
S203 N109 N110 Vread4 0 SW
S205 N110 N111 Vread4 0 SW
S207 N111 N112 Vread4 0 SW
S209 Vr N113 Vread5 0 SW
S211 N113 N114 Vread5 0 SW
S213 N114 N115 Vread5 0 SW

```

S215 N115 N116 Vread5 0 SW  
S217 N116 N117 Vread5 0 SW  
S219 N117 N118 Vread5 0 SW  
S221 N118 N119 Vread5 0 SW  
S223 N119 N120 Vread5 0 SW  
S225 Vr N121 Vread6 0 SW  
S227 N121 N122 Vread6 0 SW  
S229 N122 N123 Vread6 0 SW  
S231 N123 N124 Vread6 0 SW  
S233 N124 N125 Vread6 0 SW  
S235 N125 N126 Vread6 0 SW  
S237 N126 N127 Vread6 0 SW  
S239 N127 N128 Vread6 0 SW  
S241 Vr N129 Vread7 0 SW  
S243 N129 N130 Vread7 0 SW  
S245 N130 N131 Vread7 0 SW  
S247 N131 N132 Vread7 0 SW  
S249 N132 N133 Vread7 0 SW  
S251 N133 N134 Vread7 0 SW  
S253 N134 N135 Vread7 0 SW  
S255 N135 N136 Vread7 0 SW  
S257 Vr N137 Vread8 0 SW  
S259 N137 N138 Vread8 0 SW  
S261 N138 N139 Vread8 0 SW  
S263 N139 N140 Vread8 0 SW  
S265 N140 N141 Vread8 0 SW  
S267 N141 N142 Vread8 0 SW  
S269 N142 N143 Vread8 0 SW  
S271 N143 N144 Vread8 0 SW  
S146 Vn N081 Vwrite 0 SW  
S148 Vn N082 Vwrite 0 SW  
S150 Vn N083 Vwrite 0 SW  
S152 Vn N084 Vwrite 0 SW  
S154 Vn N085 Vwrite 0 SW  
S156 Vn N086 Vwrite 0 SW  
S158 Vn N087 Vwrite 0 SW  
S160 Vn N088 Vwrite 0 SW  
S162 Vn N089 Vwrite 0 SW  
S164 Vn N090 Vwrite 0 SW  
S166 Vn N091 Vwrite 0 SW  
S168 Vn N092 Vwrite 0 SW  
S170 Vn N093 Vwrite 0 SW  
S172 Vn N094 Vwrite 0 SW  
S174 Vn N095 Vwrite 0 SW  
S176 Vn N096 Vwrite 0 SW  
S178 Vn N097 Vwrite 0 SW  
S180 Vn N098 Vwrite 0 SW  
S182 Vn N099 Vwrite 0 SW  
S184 Vn N100 Vwrite 0 SW  
S186 Vn N101 Vwrite 0 SW  
S188 Vp N102 Vwrite 0 SW  
S190 Vn N103 Vwrite 0 SW  
S192 Vp N104 Vwrite 0 SW  
S194 Vn N105 Vwrite 0 SW  
S196 Vn N106 Vwrite 0 SW  
S198 Vn N107 Vwrite 0 SW  
S200 Vn N108 Vwrite 0 SW  
S202 Vn N109 Vwrite 0 SW  
S204 Vn N110 Vwrite 0 SW  
S206 Vn N111 Vwrite 0 SW  
S208 Vp N112 Vwrite 0 SW  
S210 Vn N113 Vwrite 0 SW  
S212 Vn N114 Vwrite 0 SW  
S214 Vn N115 Vwrite 0 SW  
S216 Vn N116 Vwrite 0 SW  
S218 Vn N117 Vwrite 0 SW  
S220 Vp N118 Vwrite 0 SW  
S222 Vp N119 Vwrite 0 SW  
S224 Vp N120 Vwrite 0 SW  
S226 Vn N121 Vwrite 0 SW  
S228 Vn N122 Vwrite 0 SW  
S230 Vn N123 Vwrite 0 SW  
S232 Vn N124 Vwrite 0 SW  
S234 Vn N125 Vwrite 0 SW  
S236 Vn N126 Vwrite 0 SW  
S238 Vn N127 Vwrite 0 SW  
S240 Vn N128 Vwrite 0 SW  
S242 Vn N129 Vwrite 0 SW  
S244 Vn N130 Vwrite 0 SW  
S246 Vn N131 Vwrite 0 SW  
S248 Vn N132 Vwrite 0 SW  
S250 Vn N133 Vwrite 0 SW  
S252 Vn N134 Vwrite 0 SW  
S254 Vn N135 Vwrite 0 SW

S256 Vn N136 Vwrite 0 SW  
S258 Vn N137 Vwrite 0 SW  
S260 Vn N138 Vwrite 0 SW  
S262 Vn N139 Vwrite 0 SW  
S264 Vn N140 Vwrite 0 SW  
S266 Vn N141 Vwrite 0 SW  
S268 Vn N142 Vwrite 0 SW  
S270 Vn N143 Vwrite 0 SW  
S272 Vn N144 Vwrite 0 SW  
S273 0 N145 Vwrite 0 SW  
S274 0 N146 Vwrite 0 SW  
S275 0 N147 Vwrite 0 SW  
S276 0 N148 Vwrite 0 SW  
S277 0 N149 Vwrite 0 SW  
S278 0 N150 Vwrite 0 SW  
S279 0 N151 Vwrite 0 SW  
S280 0 N152 Vwrite 0 SW  
XU73 N145 N081 MScammodel MScammodel  
XU74 N146 N082 MScammodel MScammodel  
XU75 N147 N083 MScammodel MScammodel  
XU76 N148 N084 MScammodel MScammodel  
XU77 N149 N085 MScammodel MScammodel  
XU78 N150 N086 MScammodel MScammodel  
XU79 N151 N087 MScammodel MScammodel  
XU80 N152 N088 MScammodel MScammodel  
XU81 N145 N089 MScammodel MScammodel  
XU82 N146 N090 MScammodel MScammodel  
XU83 N147 N091 MScammodel MScammodel  
XU84 N148 N092 MScammodel MScammodel  
XU85 N149 N093 MScammodel MScammodel  
XU86 N150 N094 MScammodel MScammodel  
XU87 N151 N095 MScammodel MScammodel  
XU88 N152 N096 MScammodel MScammodel  
XU89 N145 N097 MScammodel MScammodel  
XU90 N146 N098 MScammodel MScammodel  
XU91 N147 N099 MScammodel MScammodel  
XU92 N148 N100 MScammodel MScammodel  
XU93 N149 N101 MScammodel MScammodel  
XU94 N150 N102 MScammodel MScammodel  
XU95 N151 N103 MScammodel MScammodel  
XU96 N152 N104 MScammodel MScammodel  
XU97 N145 N105 MScammodel MScammodel  
XU98 N146 N106 MScammodel MScammodel  
XU99 N147 N107 MScammodel MScammodel  
XU100 N148 N108 MScammodel MScammodel  
XU101 N149 N109 MScammodel MScammodel  
XU102 N150 N110 MScammodel MScammodel  
XU103 N151 N111 MScammodel MScammodel  
XU104 N152 N112 MScammodel MScammodel  
XU105 N145 N113 MScammodel MScammodel  
XU106 N146 N114 MScammodel MScammodel  
XU107 N147 N115 MScammodel MScammodel  
XU108 N148 N116 MScammodel MScammodel  
XU109 N149 N117 MScammodel MScammodel  
XU110 N150 N118 MScammodel MScammodel  
XU111 N151 N119 MScammodel MScammodel  
XU112 N152 N120 MScammodel MScammodel  
XU113 N145 N121 MScammodel MScammodel  
XU114 N146 N122 MScammodel MScammodel  
XU115 N147 N123 MScammodel MScammodel  
XU116 N148 N124 MScammodel MScammodel  
XU117 N149 N125 MScammodel MScammodel  
XU118 N150 N126 MScammodel MScammodel  
XU119 N151 N127 MScammodel MScammodel  
XU120 N152 N128 MScammodel MScammodel  
XU121 N145 N129 MScammodel MScammodel  
XU122 N146 N130 MScammodel MScammodel  
XU123 N147 N131 MScammodel MScammodel  
XU124 N148 N132 MScammodel MScammodel  
XU125 N149 N133 MScammodel MScammodel  
XU126 N150 N134 MScammodel MScammodel  
XU127 N151 N135 MScammodel MScammodel  
XU128 N152 N136 MScammodel MScammodel  
XU129 N145 N137 MScammodel MScammodel  
XU130 N146 N138 MScammodel MScammodel  
XU131 N147 N139 MScammodel MScammodel  
XU132 N148 N140 MScammodel MScammodel  
XU133 N149 N141 MScammodel MScammodel  
XU134 N150 N142 MScammodel MScammodel  
XU135 N151 N143 MScammodel MScammodel  
XU136 N152 N144 MScammodel MScammodel  
S281 N145 N153 Vreadcol1 0 SW  
S282 N146 N154 Vreadcol2 0 SW  
S283 N147 N155 Vreadcol3 0 SW

```

S284 N148 N156 Vreadcol4 0 SW
S285 N149 N157 Vreadcol5 0 SW
S286 N150 N158 Vreadcol6 0 SW
S287 N151 N159 Vreadcol7 0 SW
S288 N152 N160 Vreadcol8 0 SW
R9 N153 0 57k
R10 N154 0 57k
R11 N155 0 57k
R12 N156 0 57k
R13 N157 0 57k
R14 N158 0 57k
R15 N159 0 57k
R16 N160 0 57k
XU137 N153 Vrefcross Vcccomp Vnncomp Voutread21 ua741
XU138 N154 Vrefcross Vcccomp Vnncomp Voutread22 ua741
XU139 N155 Vrefcross Vcccomp Vnncomp Voutread23 ua741
XU140 N156 Vrefcross Vcccomp Vnncomp Voutread24 ua741
XU141 N157 Vrefcross Vcccomp Vnncomp Voutread25 ua741
XU142 N158 Vrefcross Vcccomp Vnncomp Voutread26 ua741
XU143 N159 Vrefcross Vcccomp Vnncomp Voutread27 ua741
XU144 N160 Vrefcross Vcccomp Vnncomp Voutread28 ua741
A21 Voutread21 Voutread61 0 0 0 0 Vxored21 0 XOR td=0.27u
A22 Voutread22 Voutread62 0 0 0 0 Vxored22 0 XOR td=0.27u
A23 Voutread23 Voutread63 0 0 0 0 Vxored23 0 XOR td=0.27u
A24 Voutread24 Voutread64 0 0 0 0 Vxored24 0 XOR td=0.27u
A25 Voutread25 Voutread65 0 0 0 0 Vxored25 0 XOR td=0.27u
A26 Voutread26 Voutread66 0 0 0 0 Vxored26 0 XOR td=0.27u
A27 Voutread27 Voutread67 0 0 0 0 Vxored27 0 XOR td=0.27u
A28 Voutread28 Voutread68 0 0 0 0 Vxored28 0 XOR td=0.27u
Rin21 Vxored21 Vinput11 4k
Rin22 Vxored22 Vinput12 4k
Rin23 Vxored23 Vinput13 4k
Rin24 Vxored24 Vinput14 4k
Rin25 Vxored25 Vinput15 4k
Rin26 Vxored26 Vinput16 4k
Rin27 Vxored27 Vinput17 4k
Rin28 Vxored28 Vinput18 4k
S289 Vr N161 Vread1 0 SW
S291 N161 N162 Vread1 0 SW
S293 N162 N163 Vread1 0 SW
S295 N163 N164 Vread1 0 SW
S297 N164 N165 Vread1 0 SW
S299 N165 N166 Vread1 0 SW
S301 N166 N167 Vread1 0 SW
S303 N167 N168 Vread1 0 SW
S305 Vr N169 Vread2 0 SW
S307 N169 N170 Vread2 0 SW
S309 N170 N171 Vread2 0 SW
S311 N171 N172 Vread2 0 SW
S313 N172 N173 Vread2 0 SW
S315 N173 N174 Vread2 0 SW
S317 N174 N175 Vread2 0 SW
S319 N175 N176 Vread2 0 SW
S321 Vr N177 Vread3 0 SW
S323 N177 N178 Vread3 0 SW
S325 N178 N179 Vread3 0 SW
S327 N179 N180 Vread3 0 SW
S329 N180 N181 Vread3 0 SW
S331 N181 N182 Vread3 0 SW
S333 N182 N183 Vread3 0 SW
S335 N183 N184 Vread3 0 SW
S337 Vr N185 Vread4 0 SW
S339 N185 N186 Vread4 0 SW
S341 N186 N187 Vread4 0 SW
S343 N187 N188 Vread4 0 SW
S345 N188 N189 Vread4 0 SW
S347 N189 N190 Vread4 0 SW
S349 N190 N191 Vread4 0 SW
S351 N191 N192 Vread4 0 SW
S353 Vr N193 Vread5 0 SW
S355 N193 N194 Vread5 0 SW
S357 N194 N195 Vread5 0 SW
S359 N195 N196 Vread5 0 SW
S361 N196 N197 Vread5 0 SW
S363 N197 N198 Vread5 0 SW
S365 N198 N199 Vread5 0 SW
S367 N199 N200 Vread5 0 SW
S369 Vr N201 Vread6 0 SW
S371 N201 N202 Vread6 0 SW
S373 N202 N203 Vread6 0 SW
S375 N203 N204 Vread6 0 SW
S377 N204 N205 Vread6 0 SW
S379 N205 N206 Vread6 0 SW
S381 N206 N207 Vread6 0 SW

```

S383 N207 N208 Vread6 0 SW  
S385 Vr N209 Vread7 0 SW  
S387 N209 N210 Vread7 0 SW  
S389 N210 N211 Vread7 0 SW  
S391 N211 N212 Vread7 0 SW  
S393 N212 N213 Vread7 0 SW  
S395 N213 N214 Vread7 0 SW  
S397 N214 N215 Vread7 0 SW  
S399 N215 N216 Vread7 0 SW  
S401 Vr N217 Vread8 0 SW  
S403 N217 N218 Vread8 0 SW  
S405 N218 N219 Vread8 0 SW  
S407 N219 N220 Vread8 0 SW  
S409 N220 N221 Vread8 0 SW  
S411 N221 N222 Vread8 0 SW  
S413 N222 N223 Vread8 0 SW  
S415 N223 N224 Vread8 0 SW  
S290 Vn N161 Vwrite 0 SW  
S292 Vn N162 Vwrite 0 SW  
S294 Vn N163 Vwrite 0 SW  
S296 Vn N164 Vwrite 0 SW  
S298 Vn N165 Vwrite 0 SW  
S300 Vn N166 Vwrite 0 SW  
S302 Vn N167 Vwrite 0 SW  
S304 Vn N168 Vwrite 0 SW  
S306 Vn N169 Vwrite 0 SW  
S308 Vn N170 Vwrite 0 SW  
S310 Vn N171 Vwrite 0 SW  
S312 Vn N172 Vwrite 0 SW  
S314 Vn N173 Vwrite 0 SW  
S316 Vn N174 Vwrite 0 SW  
S318 Vn N175 Vwrite 0 SW  
S320 Vn N176 Vwrite 0 SW  
S322 Vn N177 Vwrite 0 SW  
S324 Vn N178 Vwrite 0 SW  
S326 Vn N179 Vwrite 0 SW  
S328 Vn N180 Vwrite 0 SW  
S330 Vn N181 Vwrite 0 SW  
S332 Vn N182 Vwrite 0 SW  
S334 Vp N183 Vwrite 0 SW  
S336 Vn N184 Vwrite 0 SW  
S338 Vn N185 Vwrite 0 SW  
S340 Vn N186 Vwrite 0 SW  
S342 Vn N187 Vwrite 0 SW  
S344 Vn N188 Vwrite 0 SW  
S346 Vn N189 Vwrite 0 SW  
S348 Vp N190 Vwrite 0 SW  
S350 Vn N191 Vwrite 0 SW  
S352 Vp N192 Vwrite 0 SW  
S354 Vn N193 Vwrite 0 SW  
S356 Vn N194 Vwrite 0 SW  
S358 Vn N195 Vwrite 0 SW  
S360 Vn N196 Vwrite 0 SW  
S362 Vn N197 Vwrite 0 SW  
S364 Vp N198 Vwrite 0 SW  
S366 Vp N199 Vwrite 0 SW  
S368 Vp N200 Vwrite 0 SW  
S370 Vn N201 Vwrite 0 SW  
S372 Vn N202 Vwrite 0 SW  
S374 Vn N203 Vwrite 0 SW  
S376 Vn N204 Vwrite 0 SW  
S378 Vn N205 Vwrite 0 SW  
S380 Vn N206 Vwrite 0 SW  
S382 Vn N207 Vwrite 0 SW  
S384 Vp N208 Vwrite 0 SW  
S386 Vn N209 Vwrite 0 SW  
S388 Vn N210 Vwrite 0 SW  
S390 Vn N211 Vwrite 0 SW  
S392 Vn N212 Vwrite 0 SW  
S394 Vn N213 Vwrite 0 SW  
S396 Vn N214 Vwrite 0 SW  
S398 Vn N215 Vwrite 0 SW  
S400 Vn N216 Vwrite 0 SW  
S402 Vn N217 Vwrite 0 SW  
S404 Vn N218 Vwrite 0 SW  
S406 Vn N219 Vwrite 0 SW  
S408 Vn N220 Vwrite 0 SW  
S410 Vn N221 Vwrite 0 SW  
S412 Vn N222 Vwrite 0 SW  
S414 Vn N223 Vwrite 0 SW  
S416 Vn N224 Vwrite 0 SW  
S417 0 N225 Vwrite 0 SW  
S418 0 N226 Vwrite 0 SW  
S419 0 N227 Vwrite 0 SW

```

S420 0 N228 Vwrite 0 SW
S421 0 N229 Vwrite 0 SW
S422 0 N230 Vwrite 0 SW
S423 0 N231 Vwrite 0 SW
S424 0 N232 Vwrite 0 SW
XU145 N225 N161 MScammodel MScammodel
XU146 N226 N162 MScammodel MScammodel
XU147 N227 N163 MScammodel MScammodel
XU148 N228 N164 MScammodel MScammodel
XU149 N229 N165 MScammodel MScammodel
XU150 N230 N166 MScammodel MScammodel
XU151 N231 N167 MScammodel MScammodel
XU152 N232 N168 MScammodel MScammodel
XU153 N225 N169 MScammodel MScammodel
XU154 N226 N170 MScammodel MScammodel
XU155 N227 N171 MScammodel MScammodel
XU156 N228 N172 MScammodel MScammodel
XU157 N229 N173 MScammodel MScammodel
XU158 N230 N174 MScammodel MScammodel
XU159 N231 N175 MScammodel MScammodel
XU160 N232 N176 MScammodel MScammodel
XU161 N225 N177 MScammodel MScammodel
XU162 N226 N178 MScammodel MScammodel
XU163 N227 N179 MScammodel MScammodel
XU164 N228 N180 MScammodel MScammodel
XU165 N229 N181 MScammodel MScammodel
XU166 N230 N182 MScammodel MScammodel
XU167 N231 N183 MScammodel MScammodel
XU168 N232 N184 MScammodel MScammodel
XU169 N225 N185 MScammodel MScammodel
XU170 N226 N186 MScammodel MScammodel
XU171 N227 N187 MScammodel MScammodel
XU172 N228 N188 MScammodel MScammodel
XU173 N229 N189 MScammodel MScammodel
XU174 N230 N190 MScammodel MScammodel
XU175 N231 N191 MScammodel MScammodel
XU176 N232 N192 MScammodel MScammodel
XU177 N225 N193 MScammodel MScammodel
XU178 N226 N194 MScammodel MScammodel
XU179 N227 N195 MScammodel MScammodel
XU180 N228 N196 MScammodel MScammodel
XU181 N229 N197 MScammodel MScammodel
XU182 N230 N198 MScammodel MScammodel
XU183 N231 N199 MScammodel MScammodel
XU184 N232 N200 MScammodel MScammodel
XU185 N225 N201 MScammodel MScammodel
XU186 N226 N202 MScammodel MScammodel
XU187 N227 N203 MScammodel MScammodel
XU188 N228 N204 MScammodel MScammodel
XU189 N229 N205 MScammodel MScammodel
XU190 N230 N206 MScammodel MScammodel
XU191 N231 N207 MScammodel MScammodel
XU192 N232 N208 MScammodel MScammodel
XU193 N225 N209 MScammodel MScammodel
XU194 N226 N210 MScammodel MScammodel
XU195 N227 N211 MScammodel MScammodel
XU196 N228 N212 MScammodel MScammodel
XU197 N229 N213 MScammodel MScammodel
XU198 N230 N214 MScammodel MScammodel
XU199 N231 N215 MScammodel MScammodel
XU200 N232 N216 MScammodel MScammodel
XU201 N225 N217 MScammodel MScammodel
XU202 N226 N218 MScammodel MScammodel
XU203 N227 N219 MScammodel MScammodel
XU204 N228 N220 MScammodel MScammodel
XU205 N229 N221 MScammodel MScammodel
XU206 N230 N222 MScammodel MScammodel
XU207 N231 N223 MScammodel MScammodel
XU208 N232 N224 MScammodel MScammodel
S425 N225 N233 Vreadcol1 0 SW
S426 N226 N234 Vreadcol2 0 SW
S427 N227 N235 Vreadcol3 0 SW
S428 N228 N236 Vreadcol4 0 SW
S429 N229 N237 Vreadcol5 0 SW
S430 N230 N238 Vreadcol6 0 SW
S431 N231 N239 Vreadcol7 0 SW
S432 N232 N240 Vreadcol8 0 SW
R17 N233 0 57k
R18 N234 0 57k
R19 N235 0 57k
R20 N236 0 57k
R21 N237 0 57k
R22 N238 0 57k
R23 N239 0 57k

```

```

R24 N240 0 57k
XU209 N233 Vrefcross Vcccomp Vnncomp Voutread31 ua741
XU210 N234 Vrefcross Vcccomp Vnncomp Voutread32 ua741
XU211 N235 Vrefcross Vcccomp Vnncomp Voutread33 ua741
XU212 N236 Vrefcross Vcccomp Vnncomp Voutread34 ua741
XU213 N237 Vrefcross Vcccomp Vnncomp Voutread35 ua741
XU214 N238 Vrefcross Vcccomp Vnncomp Voutread36 ua741
XU215 N239 Vrefcross Vcccomp Vnncomp Voutread37 ua741
XU216 N240 Vrefcross Vcccomp Vnncomp Voutread38 ua741
A31 Voutread31 Voutread71 0 0 0 0 Vxored31 0 XOR td=0.27u
A32 Voutread32 Voutread72 0 0 0 0 Vxored32 0 XOR td=0.27u
A33 Voutread33 Voutread73 0 0 0 0 Vxored33 0 XOR td=0.27u
A34 Voutread34 Voutread74 0 0 0 0 Vxored34 0 XOR td=0.27u
A35 Voutread35 Voutread75 0 0 0 0 Vxored35 0 XOR td=0.27u
A36 Voutread36 Voutread76 0 0 0 0 Vxored36 0 XOR td=0.27u
A37 Voutread37 Voutread77 0 0 0 0 Vxored37 0 XOR td=0.27u
A38 Voutread38 Voutread78 0 0 0 0 Vxored38 0 XOR td=0.27u
Rin31 Vxored31 Vinput11 8k
Rin32 Vxored32 Vinput12 8k
Rin33 Vxored33 Vinput13 8k
Rin34 Vxored34 Vinput14 8k
Rin35 Vxored35 Vinput15 8k
Rin36 Vxored36 Vinput16 8k
Rin37 Vxored37 Vinput17 8k
Rin38 Vxored38 Vinput18 8k
S433 Vr N241 Vread1 0 SW
S435 N241 N242 Vread1 0 SW
S437 N242 N243 Vread1 0 SW
S439 N243 N244 Vread1 0 SW
S441 N244 N245 Vread1 0 SW
S443 N245 N246 Vread1 0 SW
S445 N246 N247 Vread1 0 SW
S447 N247 N248 Vread1 0 SW
S449 Vr N249 Vread2 0 SW
S451 N249 N250 Vread2 0 SW
S453 N250 N251 Vread2 0 SW
S455 N251 N252 Vread2 0 SW
S457 N252 N253 Vread2 0 SW
S459 N253 N254 Vread2 0 SW
S461 N254 N255 Vread2 0 SW
S463 N255 N256 Vread2 0 SW
S465 Vr N257 Vread3 0 SW
S467 N257 N258 Vread3 0 SW
S469 N258 N259 Vread3 0 SW
S471 N259 N260 Vread3 0 SW
S473 N260 N261 Vread3 0 SW
S475 N261 N262 Vread3 0 SW
S477 N262 N263 Vread3 0 SW
S479 N263 N264 Vread3 0 SW
S481 Vr N265 Vread4 0 SW
S483 N265 N266 Vread4 0 SW
S485 N266 N267 Vread4 0 SW
S487 N267 N268 Vread4 0 SW
S489 N268 N269 Vread4 0 SW
S491 N269 N270 Vread4 0 SW
S493 N270 N271 Vread4 0 SW
S495 N271 N272 Vread4 0 SW
S497 Vr N273 Vread5 0 SW
S499 N273 N274 Vread5 0 SW
S501 N274 N275 Vread5 0 SW
S503 N275 N276 Vread5 0 SW
S505 N276 N277 Vread5 0 SW
S507 N277 N278 Vread5 0 SW
S509 N278 N279 Vread5 0 SW
S511 N279 N280 Vread5 0 SW
S513 Vr N281 Vread6 0 SW
S515 N281 N282 Vread6 0 SW
S517 N282 N283 Vread6 0 SW
S519 N283 N284 Vread6 0 SW
S521 N284 N285 Vread6 0 SW
S523 N285 N286 Vread6 0 SW
S525 N286 N287 Vread6 0 SW
S527 N287 N288 Vread6 0 SW
S529 Vr N289 Vread7 0 SW
S531 N289 N290 Vread7 0 SW
S533 N290 N291 Vread7 0 SW
S535 N291 N292 Vread7 0 SW
S537 N292 N293 Vread7 0 SW
S539 N293 N294 Vread7 0 SW
S541 N294 N295 Vread7 0 SW
S543 N295 N296 Vread7 0 SW
S545 Vr N297 Vread8 0 SW
S547 N297 N298 Vread8 0 SW
S549 N298 N299 Vread8 0 SW

```

```

S551 N299 N300 Vread8 0 SW
S553 N300 N301 Vread8 0 SW
S555 N301 N302 Vread8 0 SW
S557 N302 N303 Vread8 0 SW
S559 N303 N304 Vread8 0 SW
S434 Vp N241 Vwrite 0 SW
S436 Vp N242 Vwrite 0 SW
S438 Vp N243 Vwrite 0 SW
S440 Vp N244 Vwrite 0 SW
S442 Vp N245 Vwrite 0 SW
S444 Vp N246 Vwrite 0 SW
S446 Vp N247 Vwrite 0 SW
S448 Vp N248 Vwrite 0 SW
S450 Vp N249 Vwrite 0 SW
S452 Vp N250 Vwrite 0 SW
S454 Vp N251 Vwrite 0 SW
S456 Vp N252 Vwrite 0 SW
S458 Vp N253 Vwrite 0 SW
S460 Vp N254 Vwrite 0 SW
S462 Vn N255 Vwrite 0 SW
S464 Vp N256 Vwrite 0 SW
S466 Vp N257 Vwrite 0 SW
S468 Vp N258 Vwrite 0 SW
S470 Vp N259 Vwrite 0 SW
S472 Vp N260 Vwrite 0 SW
S474 Vp N261 Vwrite 0 SW
S476 Vp N262 Vwrite 0 SW
S478 Vn N263 Vwrite 0 SW
S480 Vp N264 Vwrite 0 SW
S482 Vp N265 Vwrite 0 SW
S484 Vp N266 Vwrite 0 SW
S486 Vp N267 Vwrite 0 SW
S488 Vp N268 Vwrite 0 SW
S490 Vn N269 Vwrite 0 SW
S492 Vn N270 Vwrite 0 SW
S494 Vp N271 Vwrite 0 SW
S496 Vn N272 Vwrite 0 SW
S498 Vp N273 Vwrite 0 SW
S500 Vp N274 Vwrite 0 SW
S502 Vp N275 Vwrite 0 SW
S504 Vp N276 Vwrite 0 SW
S506 Vp N277 Vwrite 0 SW
S508 Vp N278 Vwrite 0 SW
S510 Vn N279 Vwrite 0 SW
S512 Vp N280 Vwrite 0 SW
S514 Vp N281 Vwrite 0 SW
S516 Vp N282 Vwrite 0 SW
S518 Vp N283 Vwrite 0 SW
S520 Vp N284 Vwrite 0 SW
S522 Vp N285 Vwrite 0 SW
S524 Vp N286 Vwrite 0 SW
S526 Vp N287 Vwrite 0 SW
S528 Vp N288 Vwrite 0 SW
S530 Vp N289 Vwrite 0 SW
S532 Vp N290 Vwrite 0 SW
S534 Vp N291 Vwrite 0 SW
S536 Vp N292 Vwrite 0 SW
S538 Vp N293 Vwrite 0 SW
S540 Vp N294 Vwrite 0 SW
S542 Vp N295 Vwrite 0 SW
S544 Vp N296 Vwrite 0 SW
S546 Vp N297 Vwrite 0 SW
S548 Vp N298 Vwrite 0 SW
S550 Vp N299 Vwrite 0 SW
S552 Vp N300 Vwrite 0 SW
S554 Vp N301 Vwrite 0 SW
S556 Vp N302 Vwrite 0 SW
S558 Vp N303 Vwrite 0 SW
S560 Vp N304 Vwrite 0 SW
S561 0 N305 Vwrite 0 SW
S562 0 N306 Vwrite 0 SW
S563 0 N307 Vwrite 0 SW
S564 0 N308 Vwrite 0 SW
S565 0 N309 Vwrite 0 SW
S566 0 N310 Vwrite 0 SW
S567 0 N311 Vwrite 0 SW
S568 0 N312 Vwrite 0 SW
XU217 N305 N241 MScammodel MScammodel
XU218 N306 N242 MScammodel MScammodel
XU219 N307 N243 MScammodel MScammodel
XU220 N308 N244 MScammodel MScammodel
XU221 N309 N245 MScammodel MScammodel
XU222 N310 N246 MScammodel MScammodel
XU223 N311 N247 MScammodel MScammodel

```

```

XU224 N312 N248 MScammodel MScammodel
XU225 N305 N249 MScammodel MScammodel
XU226 N306 N250 MScammodel MScammodel
XU227 N307 N251 MScammodel MScammodel
XU228 N308 N252 MScammodel MScammodel
XU229 N309 N253 MScammodel MScammodel
XU230 N310 N254 MScammodel MScammodel
XU231 N311 N255 MScammodel MScammodel
XU232 N312 N256 MScammodel MScammodel
XU233 N305 N257 MScammodel MScammodel
XU234 N306 N258 MScammodel MScammodel
XU235 N307 N259 MScammodel MScammodel
XU236 N308 N260 MScammodel MScammodel
XU237 N309 N261 MScammodel MScammodel
XU238 N310 N262 MScammodel MScammodel
XU239 N311 N263 MScammodel MScammodel
XU240 N312 N264 MScammodel MScammodel
XU241 N305 N265 MScammodel MScammodel
XU242 N306 N266 MScammodel MScammodel
XU243 N307 N267 MScammodel MScammodel
XU244 N308 N268 MScammodel MScammodel
XU245 N309 N269 MScammodel MScammodel
XU246 N310 N270 MScammodel MScammodel
XU247 N311 N271 MScammodel MScammodel
XU248 N312 N272 MScammodel MScammodel
XU249 N305 N273 MScammodel MScammodel
XU250 N306 N274 MScammodel MScammodel
XU251 N307 N275 MScammodel MScammodel
XU252 N308 N276 MScammodel MScammodel
XU253 N309 N277 MScammodel MScammodel
XU254 N310 N278 MScammodel MScammodel
XU255 N311 N279 MScammodel MScammodel
XU256 N312 N280 MScammodel MScammodel
XU257 N305 N281 MScammodel MScammodel
XU258 N306 N282 MScammodel MScammodel
XU259 N307 N283 MScammodel MScammodel
XU260 N308 N284 MScammodel MScammodel
XU261 N309 N285 MScammodel MScammodel
XU262 N310 N286 MScammodel MScammodel
XU263 N311 N287 MScammodel MScammodel
XU264 N312 N288 MScammodel MScammodel
XU265 N305 N289 MScammodel MScammodel
XU266 N306 N290 MScammodel MScammodel
XU267 N307 N291 MScammodel MScammodel
XU268 N308 N292 MScammodel MScammodel
XU269 N309 N293 MScammodel MScammodel
XU270 N310 N294 MScammodel MScammodel
XU271 N311 N295 MScammodel MScammodel
XU272 N312 N296 MScammodel MScammodel
XU273 N305 N297 MScammodel MScammodel
XU274 N306 N298 MScammodel MScammodel
XU275 N307 N299 MScammodel MScammodel
XU276 N308 N300 MScammodel MScammodel
XU277 N309 N301 MScammodel MScammodel
XU278 N310 N302 MScammodel MScammodel
XU279 N311 N303 MScammodel MScammodel
XU280 N312 N304 MScammodel MScammodel
S569 N305 N313 Vreadcol1 0 SW
S570 N306 N314 Vreadcol2 0 SW
S571 N307 N315 Vreadcol3 0 SW
S572 N308 N316 Vreadcol4 0 SW
S573 N309 N317 Vreadcol5 0 SW
S574 N310 N318 Vreadcol6 0 SW
S575 N311 N319 Vreadcol7 0 SW
S576 N312 N320 Vreadcol8 0 SW
R25 N313 0 57k
R26 N314 0 57k
R27 N315 0 57k
R28 N316 0 57k
R29 N317 0 57k
R30 N318 0 57k
R31 N319 0 57k
R32 N320 0 57k
XU281 N313 Vrefcross Vcccomp Vnncomp Voutread41 ua741
XU282 N314 Vrefcross Vcccomp Vnncomp Voutread42 ua741
XU283 N315 Vrefcross Vcccomp Vnncomp Voutread43 ua741
XU284 N316 Vrefcross Vcccomp Vnncomp Voutread44 ua741
XU285 N317 Vrefcross Vcccomp Vnncomp Voutread45 ua741
XU286 N318 Vrefcross Vcccomp Vnncomp Voutread46 ua741
XU287 N319 Vrefcross Vcccomp Vnncomp Voutread47 ua741
XU288 N320 Vrefcross Vcccomp Vnncomp Voutread48 ua741
A41 Voutread41 Voutread81 0 0 0 0 Vxored41 0 XOR td=0.27u
A42 Voutread42 Voutread82 0 0 0 0 Vxored42 0 XOR td=0.27u
A43 Voutread43 Voutread83 0 0 0 0 Vxored43 0 XOR td=0.27u

```

```

A44 Voutread44 Voutread84 0 0 0 0 Vxored44 0 XOR td=0.27u
A45 Voutread45 Voutread85 0 0 0 0 Vxored45 0 XOR td=0.27u
A46 Voutread46 Voutread86 0 0 0 0 Vxored46 0 XOR td=0.27u
A47 Voutread47 Voutread87 0 0 0 0 Vxored47 0 XOR td=0.27u
A48 Voutread48 Voutread88 0 0 0 0 Vxored48 0 XOR td=0.27u
Rin41 Vxored41 Vinput11 16k
Rin42 Vxored42 Vinput12 16k
Rin43 Vxored43 Vinput13 16k
Rin44 Vxored44 Vinput14 16k
Rin45 Vxored45 Vinput15 16k
Rin46 Vxored46 Vinput16 16k
Rin47 Vxored47 Vinput17 16k
Rin48 Vxored48 Vinput18 16k
S577 Vr N321 Vread1 0 SW
S579 N321 N322 Vread1 0 SW
S581 N322 N323 Vread1 0 SW
S583 N323 N324 Vread1 0 SW
S585 N324 N325 Vread1 0 SW
S587 N325 N326 Vread1 0 SW
S589 N326 N327 Vread1 0 SW
S591 N327 N328 Vread1 0 SW
S593 Vr N329 Vread2 0 SW
S595 N329 N330 Vread2 0 SW
S597 N330 N331 Vread2 0 SW
S599 N331 N332 Vread2 0 SW
S601 N332 N333 Vread2 0 SW
S603 N333 N334 Vread2 0 SW
S605 N334 N335 Vread2 0 SW
S607 N335 N336 Vread2 0 SW
S609 Vr N337 Vread3 0 SW
S611 N337 N338 Vread3 0 SW
S613 N338 N339 Vread3 0 SW
S615 N339 N340 Vread3 0 SW
S617 N340 N341 Vread3 0 SW
S619 N341 N342 Vread3 0 SW
S621 N342 N343 Vread3 0 SW
S623 N343 N344 Vread3 0 SW
S625 Vr N345 Vread4 0 SW
S627 N345 N346 Vread4 0 SW
S629 N346 N347 Vread4 0 SW
S631 N347 N348 Vread4 0 SW
S633 N348 N349 Vread4 0 SW
S635 N349 N350 Vread4 0 SW
S637 N350 N351 Vread4 0 SW
S639 N351 N352 Vread4 0 SW
S641 Vr N353 Vread5 0 SW
S643 N353 N354 Vread5 0 SW
S645 N354 N355 Vread5 0 SW
S647 N355 N356 Vread5 0 SW
S649 N356 N357 Vread5 0 SW
S651 N357 N358 Vread5 0 SW
S653 N358 N359 Vread5 0 SW
S655 N359 N360 Vread5 0 SW
S657 Vr N361 Vread6 0 SW
S659 N361 N362 Vread6 0 SW
S661 N362 N363 Vread6 0 SW
S663 N363 N364 Vread6 0 SW
S665 N364 N365 Vread6 0 SW
S667 N365 N366 Vread6 0 SW
S669 N366 N367 Vread6 0 SW
S671 N367 N368 Vread6 0 SW
S673 Vr N369 Vread7 0 SW
S675 N369 N370 Vread7 0 SW
S677 N370 N371 Vread7 0 SW
S679 N371 N372 Vread7 0 SW
S681 N372 N373 Vread7 0 SW
S683 N373 N374 Vread7 0 SW
S685 N374 N375 Vread7 0 SW
S687 N375 N376 Vread7 0 SW
S689 Vr N377 Vread8 0 SW
S691 N377 N378 Vread8 0 SW
S693 N378 N379 Vread8 0 SW
S695 N379 N380 Vread8 0 SW
S697 N380 N381 Vread8 0 SW
S699 N381 N382 Vread8 0 SW
S701 N382 N383 Vread8 0 SW
S703 N383 N384 Vread8 0 SW
S578 Vp N321 Vwrite 0 SW
S580 Vp N322 Vwrite 0 SW
S582 Vp N323 Vwrite 0 SW
S584 Vp N324 Vwrite 0 SW
S586 Vp N325 Vwrite 0 SW
S588 Vp N326 Vwrite 0 SW
S590 Vp N327 Vwrite 0 SW

```

S592 Vp N328 Vwrite 0 SW  
S594 Vp N329 Vwrite 0 SW  
S596 Vp N330 Vwrite 0 SW  
S598 Vp N331 Vwrite 0 SW  
S600 Vp N332 Vwrite 0 SW  
S602 Vp N333 Vwrite 0 SW  
S604 Vp N334 Vwrite 0 SW  
S606 Vp N335 Vwrite 0 SW  
S608 Vp N336 Vwrite 0 SW  
S610 Vp N337 Vwrite 0 SW  
S612 Vp N338 Vwrite 0 SW  
S614 Vp N339 Vwrite 0 SW  
S616 Vp N340 Vwrite 0 SW  
S618 Vp N341 Vwrite 0 SW  
S620 Vp N342 Vwrite 0 SW  
S622 Vp N343 Vwrite 0 SW  
S624 Vp N344 Vwrite 0 SW  
S626 Vp N345 Vwrite 0 SW  
S628 Vp N346 Vwrite 0 SW  
S630 Vp N347 Vwrite 0 SW  
S632 Vp N348 Vwrite 0 SW  
S634 Vp N349 Vwrite 0 SW  
S636 Vn N350 Vwrite 0 SW  
S638 Vp N351 Vwrite 0 SW  
S640 Vp N352 Vwrite 0 SW  
S642 Vp N353 Vwrite 0 SW  
S644 Vp N354 Vwrite 0 SW  
S646 Vp N355 Vwrite 0 SW  
S648 Vp N356 Vwrite 0 SW  
S650 Vn N357 Vwrite 0 SW  
S652 Vn N358 Vwrite 0 SW  
S654 Vn N359 Vwrite 0 SW  
S656 Vp N360 Vwrite 0 SW  
S658 Vp N361 Vwrite 0 SW  
S660 Vp N362 Vwrite 0 SW  
S662 Vp N363 Vwrite 0 SW  
S664 Vp N364 Vwrite 0 SW  
S666 Vp N365 Vwrite 0 SW  
S668 Vn N366 Vwrite 0 SW  
S670 Vp N367 Vwrite 0 SW  
S672 Vp N368 Vwrite 0 SW  
S674 Vp N369 Vwrite 0 SW  
S676 Vp N370 Vwrite 0 SW  
S678 Vp N371 Vwrite 0 SW  
S680 Vp N372 Vwrite 0 SW  
S682 Vp N373 Vwrite 0 SW  
S684 Vp N374 Vwrite 0 SW  
S686 Vp N375 Vwrite 0 SW  
S688 Vp N376 Vwrite 0 SW  
S690 Vp N377 Vwrite 0 SW  
S692 Vp N378 Vwrite 0 SW  
S694 Vp N379 Vwrite 0 SW  
S696 Vp N380 Vwrite 0 SW  
S698 Vp N381 Vwrite 0 SW  
S700 Vp N382 Vwrite 0 SW  
S702 Vp N383 Vwrite 0 SW  
S704 Vp N384 Vwrite 0 SW  
S705 0 N385 Vwrite 0 SW  
S706 0 N386 Vwrite 0 SW  
S707 0 N387 Vwrite 0 SW  
S708 0 N388 Vwrite 0 SW  
S709 0 N389 Vwrite 0 SW  
S710 0 N390 Vwrite 0 SW  
S711 0 N391 Vwrite 0 SW  
S712 0 N392 Vwrite 0 SW  
XU289 N385 N321 MScammodel MScammodel  
XU290 N386 N322 MScammodel MScammodel  
XU291 N387 N323 MScammodel MScammodel  
XU292 N388 N324 MScammodel MScammodel  
XU293 N389 N325 MScammodel MScammodel  
XU294 N390 N326 MScammodel MScammodel  
XU295 N391 N327 MScammodel MScammodel  
XU296 N392 N328 MScammodel MScammodel  
XU297 N385 N329 MScammodel MScammodel  
XU298 N386 N330 MScammodel MScammodel  
XU299 N387 N331 MScammodel MScammodel  
XU300 N388 N332 MScammodel MScammodel  
XU301 N389 N333 MScammodel MScammodel  
XU302 N390 N334 MScammodel MScammodel  
XU303 N391 N335 MScammodel MScammodel  
XU304 N392 N336 MScammodel MScammodel  
XU305 N385 N337 MScammodel MScammodel  
XU306 N386 N338 MScammodel MScammodel  
XU307 N387 N339 MScammodel MScammodel

```

XU308 N388 N340 MScammodel MScammodel
XU309 N389 N341 MScammodel MScammodel
XU310 N390 N342 MScammodel MScammodel
XU311 N391 N343 MScammodel MScammodel
XU312 N392 N344 MScammodel MScammodel
XU313 N385 N345 MScammodel MScammodel
XU314 N386 N346 MScammodel MScammodel
XU315 N387 N347 MScammodel MScammodel
XU316 N388 N348 MScammodel MScammodel
XU317 N389 N349 MScammodel MScammodel
XU318 N390 N350 MScammodel MScammodel
XU319 N391 N351 MScammodel MScammodel
XU320 N392 N352 MScammodel MScammodel
XU321 N385 N353 MScammodel MScammodel
XU322 N386 N354 MScammodel MScammodel
XU323 N387 N355 MScammodel MScammodel
XU324 N388 N356 MScammodel MScammodel
XU325 N389 N357 MScammodel MScammodel
XU326 N390 N358 MScammodel MScammodel
XU327 N391 N359 MScammodel MScammodel
XU328 N392 N360 MScammodel MScammodel
XU329 N385 N361 MScammodel MScammodel
XU330 N386 N362 MScammodel MScammodel
XU331 N387 N363 MScammodel MScammodel
XU332 N388 N364 MScammodel MScammodel
XU333 N389 N365 MScammodel MScammodel
XU334 N390 N366 MScammodel MScammodel
XU335 N391 N367 MScammodel MScammodel
XU336 N392 N368 MScammodel MScammodel
XU337 N385 N369 MScammodel MScammodel
XU338 N386 N370 MScammodel MScammodel
XU339 N387 N371 MScammodel MScammodel
XU340 N388 N372 MScammodel MScammodel
XU341 N389 N373 MScammodel MScammodel
XU342 N390 N374 MScammodel MScammodel
XU343 N391 N375 MScammodel MScammodel
XU344 N392 N376 MScammodel MScammodel
XU345 N385 N377 MScammodel MScammodel
XU346 N386 N378 MScammodel MScammodel
XU347 N387 N379 MScammodel MScammodel
XU348 N388 N380 MScammodel MScammodel
XU349 N389 N381 MScammodel MScammodel
XU350 N390 N382 MScammodel MScammodel
XU351 N391 N383 MScammodel MScammodel
XU352 N392 N384 MScammodel MScammodel
S713 N385 N393 Vreadcol1 0 SW
S714 N386 N394 Vreadcol2 0 SW
S715 N387 N395 Vreadcol3 0 SW
S716 N388 N396 Vreadcol4 0 SW
S717 N389 N397 Vreadcol5 0 SW
S718 N390 N398 Vreadcol6 0 SW
S719 N391 N399 Vreadcol7 0 SW
S720 N392 N400 Vreadcol8 0 SW
R33 N393 0 57k
R34 N394 0 57k
R35 N395 0 57k
R36 N396 0 57k
R37 N397 0 57k
R38 N398 0 57k
R39 N399 0 57k
R40 N400 0 57k
XU353 N393 Vrefcross Vcccomp Vnncomp Voutread51 ua741
XU354 N394 Vrefcross Vcccomp Vnncomp Voutread52 ua741
XU355 N395 Vrefcross Vcccomp Vnncomp Voutread53 ua741
XU356 N396 Vrefcross Vcccomp Vnncomp Voutread54 ua741
XU357 N397 Vrefcross Vcccomp Vnncomp Voutread55 ua741
XU358 N398 Vrefcross Vcccomp Vnncomp Voutread56 ua741
XU359 N399 Vrefcross Vcccomp Vnncomp Voutread57 ua741
XU360 N400 Vrefcross Vcccomp Vnncomp Voutread58 ua741
A51 Voutread51 Voutread91 0 0 0 0 Vxored51 0 XOR td=0.27u
A52 Voutread52 Voutread92 0 0 0 0 Vxored52 0 XOR td=0.27u
A53 Voutread53 Voutread93 0 0 0 0 Vxored53 0 XOR td=0.27u
A54 Voutread54 Voutread94 0 0 0 0 Vxored54 0 XOR td=0.27u
A55 Voutread55 Voutread95 0 0 0 0 Vxored55 0 XOR td=0.27u
A56 Voutread56 Voutread96 0 0 0 0 Vxored56 0 XOR td=0.27u
A57 Voutread57 Voutread97 0 0 0 0 Vxored57 0 XOR td=0.27u
A58 Voutread58 Voutread98 0 0 0 0 Vxored58 0 XOR td=0.27u
Rin51 Vxored51 Vininput21 2k
Rfeed21 Vininput21 Vsum21 1k
XU873 0 Vininput21 Vccsum Vnnsum Vsum21 ua741
Rinvin21 Vsum21 Vininputphase21 10k
Rfeedphase21 Vininputphase21 Vinvsum21 10k
XU897 0 Vininputphase21 Vcccomp Vnncomp Vinvsum21 ua741
XU905 Vinvsum21 Vrefthresh Vcccomp Vnncomp Vtotal21 ua741

```

```

M21 Vdd Vtotal21 Vinvtotal21 Vdd CMOS l=250n w=2500n
M29 Vinvtotal21 Vtotal21 0 0 CMOSN l=250n w=2500n
Rin52 Vxored52 Vinut22 2k
Rfeed22 Vinut22 Vsum22 1k
XU874 0 Vinut22 Vccsum Vnnsum Vsum22 ua741
Rinvin22 Vsum22 Vinutphase22 10k
Rfeedphase22 Vinutphase22 Vinvsum22 10k
XU898 0 Vinutphase22 Vcccomp Vnncomp Vinvsum22 ua741
XU906 Vinvsum22 Vrefthresh Vcccomp Vnncomp Vtotal22 ua741
M22 Vdd Vtotal22 Vinvtotal22 Vdd CMOS l=250n w=2500n
M210 Vinvtotal22 Vtotal22 0 0 CMOSN l=250n w=2500n
Rin53 Vxored53 Vinut23 2k
Rfeed23 Vinut23 Vsum23 1k
XU875 0 Vinut23 Vccsum Vnnsum Vsum23 ua741
Rinvin23 Vsum23 Vinutphase23 10k
Rfeedphase23 Vinutphase23 Vinvsum23 10k
XU899 0 Vinutphase23 Vcccomp Vnncomp Vinvsum23 ua741
XU907 Vinvsum23 Vrefthresh Vcccomp Vnncomp Vtotal23 ua741
M23 Vdd Vtotal23 Vinvtotal23 Vdd CMOS l=250n w=2500n
M211 Vinvtotal23 Vtotal23 0 0 CMOSN l=250n w=2500n
Rin54 Vxored54 Vinut24 2k
Rfeed24 Vinut24 Vsum24 1k
XU876 0 Vinut24 Vccsum Vnnsum Vsum24 ua741
Rinvin24 Vsum24 Vinutphase24 10k
Rfeedphase24 Vinutphase24 Vinvsum24 10k
XU900 0 Vinutphase24 Vcccomp Vnncomp Vinvsum24 ua741
XU908 Vinvsum24 Vrefthresh Vcccomp Vnncomp Vtotal24 ua741
M24 Vdd Vtotal24 Vinvtotal24 Vdd CMOS l=250n w=2500n
M212 Vinvtotal24 Vtotal24 0 0 CMOSN l=250n w=2500n
Rin55 Vxored55 Vinut25 2k
Rfeed25 Vinut25 Vsum25 1k
XU877 0 Vinut25 Vccsum Vnnsum Vsum25 ua741
Rinvin25 Vsum25 Vinutphase25 10k
Rfeedphase25 Vinutphase25 Vinvsum25 10k
XU901 0 Vinutphase25 Vcccomp Vnncomp Vinvsum25 ua741
XU909 Vinvsum25 Vrefthresh Vcccomp Vnncomp Vtotal25 ua741
M25 Vdd Vtotal25 Vinvtotal25 Vdd CMOS l=250n w=2500n
M213 Vinvtotal25 Vtotal25 0 0 CMOSN l=250n w=2500n
Rin56 Vxored56 Vinut26 2k
Rfeed26 Vinut26 Vsum26 1k
XU878 0 Vinut26 Vccsum Vnnsum Vsum26 ua741
Rinvin26 Vsum26 Vinutphase26 10k
Rfeedphase26 Vinutphase26 Vinvsum26 10k
XU902 0 Vinutphase26 Vcccomp Vnncomp Vinvsum26 ua741
XU910 Vinvsum26 Vrefthresh Vcccomp Vnncomp Vtotal26 ua741
M26 Vdd Vtotal26 Vinvtotal26 Vdd CMOS l=250n w=2500n
M214 Vinvtotal26 Vtotal26 0 0 CMOSN l=250n w=2500n
Rin57 Vxored57 Vinut27 2k
Rfeed27 Vinut27 Vsum27 1k
XU879 0 Vinut27 Vccsum Vnnsum Vsum27 ua741
Rinvin27 Vsum27 Vinutphase27 10k
Rfeedphase27 Vinutphase27 Vinvsum27 10k
XU903 0 Vinutphase27 Vcccomp Vnncomp Vinvsum27 ua741
XU911 Vinvsum27 Vrefthresh Vcccomp Vnncomp Vtotal27 ua741
M27 Vdd Vtotal27 Vinvtotal27 Vdd CMOS l=250n w=2500n
M215 Vinvtotal27 Vtotal27 0 0 CMOSN l=250n w=2500n
Rin58 Vxored58 Vinut28 2k
Rfeed28 Vinut28 Vsum28 1k
XU880 0 Vinut28 Vccsum Vnnsum Vsum28 ua741
Rinvin28 Vsum28 Vinutphase28 10k
Rfeedphase28 Vinutphase28 Vinvsum28 10k
XU904 0 Vinutphase28 Vcccomp Vnncomp Vinvsum28 ua741
XU912 Vinvsum28 Vrefthresh Vcccomp Vnncomp Vtotal28 ua741
M28 Vdd Vtotal28 Vinvtotal28 Vdd CMOS l=250n w=2500n
M216 Vinvtotal28 Vtotal28 0 0 CMOSN l=250n w=2500n
S721 Vr N401 Vread1 0 SW
S723 N401 N402 Vread1 0 SW
S725 N402 N403 Vread1 0 SW
S727 N403 N404 Vread1 0 SW
S729 N404 N405 Vread1 0 SW
S731 N405 N406 Vread1 0 SW
S733 N406 N407 Vread1 0 SW
S735 N407 N408 Vread1 0 SW
S737 Vr N409 Vread2 0 SW
S739 N409 N410 Vread2 0 SW
S741 N410 N411 Vread2 0 SW
S743 N411 N412 Vread2 0 SW
S745 N412 N413 Vread2 0 SW
S747 N413 N414 Vread2 0 SW
S749 N414 N415 Vread2 0 SW
S751 N415 N416 Vread2 0 SW
S753 Vr N417 Vread3 0 SW
S755 N417 N418 Vread3 0 SW

```

S757 N418 N419 Vread3 0 SW  
S759 N419 N420 Vread3 0 SW  
S761 N420 N421 Vread3 0 SW  
S763 N421 N422 Vread3 0 SW  
S765 N422 N423 Vread3 0 SW  
S767 N423 N424 Vread3 0 SW  
S769 Vr N425 Vread4 0 SW  
S771 N425 N426 Vread4 0 SW  
S773 N426 N427 Vread4 0 SW  
S775 N427 N428 Vread4 0 SW  
S777 N428 N429 Vread4 0 SW  
S779 N429 N430 Vread4 0 SW  
S781 N430 N431 Vread4 0 SW  
S783 N431 N432 Vread4 0 SW  
S785 Vr N433 Vread5 0 SW  
S787 N433 N434 Vread5 0 SW  
S789 N434 N435 Vread5 0 SW  
S791 N435 N436 Vread5 0 SW  
S793 N436 N437 Vread5 0 SW  
S795 N437 N438 Vread5 0 SW  
S797 N438 N439 Vread5 0 SW  
S799 N439 N440 Vread5 0 SW  
S801 Vr N441 Vread6 0 SW  
S803 N441 N442 Vread6 0 SW  
S805 N442 N443 Vread6 0 SW  
S807 N443 N444 Vread6 0 SW  
S809 N444 N445 Vread6 0 SW  
S811 N445 N446 Vread6 0 SW  
S813 N446 N447 Vread6 0 SW  
S815 N447 N448 Vread6 0 SW  
S817 Vr N449 Vread7 0 SW  
S819 N449 N450 Vread7 0 SW  
S821 N450 N451 Vread7 0 SW  
S823 N451 N452 Vread7 0 SW  
S825 N452 N453 Vread7 0 SW  
S827 N453 N454 Vread7 0 SW  
S829 N454 N455 Vread7 0 SW  
S831 N455 N456 Vread7 0 SW  
S833 Vr N457 Vread8 0 SW  
S835 N457 N458 Vread8 0 SW  
S837 N458 N459 Vread8 0 SW  
S839 N459 N460 Vread8 0 SW  
S841 N460 N461 Vread8 0 SW  
S843 N461 N462 Vread8 0 SW  
S845 N462 N463 Vread8 0 SW  
S847 N463 N464 Vread8 0 SW  
S722 Vn N401 Vwrite 0 SW  
S724 Vn N402 Vwrite 0 SW  
S726 Vn N403 Vwrite 0 SW  
S728 Vn N404 Vwrite 0 SW  
S730 Vn N405 Vwrite 0 SW  
S732 Vn N406 Vwrite 0 SW  
S734 Vn N407 Vwrite 0 SW  
S736 Vn N408 Vwrite 0 SW  
S738 Vn N409 Vwrite 0 SW  
S740 Vn N410 Vwrite 0 SW  
S742 Vn N411 Vwrite 0 SW  
S744 Vn N412 Vwrite 0 SW  
S746 Vn N413 Vwrite 0 SW  
S748 Vn N414 Vwrite 0 SW  
S750 Vn N415 Vwrite 0 SW  
S752 Vn N416 Vwrite 0 SW  
S754 Vn N417 Vwrite 0 SW  
S756 Vn N418 Vwrite 0 SW  
S758 Vn N419 Vwrite 0 SW  
S760 Vn N420 Vwrite 0 SW  
S762 Vn N421 Vwrite 0 SW  
S764 Vn N422 Vwrite 0 SW  
S766 Vn N423 Vwrite 0 SW  
S768 Vn N424 Vwrite 0 SW  
S770 Vn N425 Vwrite 0 SW  
S772 Vn N426 Vwrite 0 SW  
S774 Vn N427 Vwrite 0 SW  
S776 Vn N428 Vwrite 0 SW  
S778 Vp N429 Vwrite 0 SW  
S780 Vn N430 Vwrite 0 SW  
S782 Vp N431 Vwrite 0 SW  
S784 Vn N432 Vwrite 0 SW  
S786 Vn N433 Vwrite 0 SW  
S788 Vn N434 Vwrite 0 SW  
S790 Vn N435 Vwrite 0 SW  
S792 Vn N436 Vwrite 0 SW  
S794 Vn N437 Vwrite 0 SW  
S796 Vn N438 Vwrite 0 SW

S798 Vp N439 Vwrite 0 SW  
S800 Vn N440 Vwrite 0 SW  
S802 Vn N441 Vwrite 0 SW  
S804 Vn N442 Vwrite 0 SW  
S806 Vn N443 Vwrite 0 SW  
S808 Vn N444 Vwrite 0 SW  
S810 Vp N445 Vwrite 0 SW  
S812 Vn N446 Vwrite 0 SW  
S814 Vp N447 Vwrite 0 SW  
S816 Vn N448 Vwrite 0 SW  
S818 Vn N449 Vwrite 0 SW  
S820 Vn N450 Vwrite 0 SW  
S822 Vn N451 Vwrite 0 SW  
S824 Vn N452 Vwrite 0 SW  
S826 Vn N453 Vwrite 0 SW  
S828 Vn N454 Vwrite 0 SW  
S830 Vn N455 Vwrite 0 SW  
S832 Vn N456 Vwrite 0 SW  
S834 Vn N457 Vwrite 0 SW  
S836 Vn N458 Vwrite 0 SW  
S838 Vn N459 Vwrite 0 SW  
S840 Vn N460 Vwrite 0 SW  
S842 Vn N461 Vwrite 0 SW  
S844 Vn N462 Vwrite 0 SW  
S846 Vn N463 Vwrite 0 SW  
S848 Vn N464 Vwrite 0 SW  
S849 0 N465 Vwrite 0 SW  
S850 0 N466 Vwrite 0 SW  
S851 0 N467 Vwrite 0 SW  
S852 0 N468 Vwrite 0 SW  
S853 0 N469 Vwrite 0 SW  
S854 0 N470 Vwrite 0 SW  
S855 0 N471 Vwrite 0 SW  
S856 0 N472 Vwrite 0 SW  
XU361 N465 N401 MScammodel MScammodel  
XU362 N466 N402 MScammodel MScammodel  
XU363 N467 N403 MScammodel MScammodel  
XU364 N468 N404 MScammodel MScammodel  
XU365 N469 N405 MScammodel MScammodel  
XU366 N470 N406 MScammodel MScammodel  
XU367 N471 N407 MScammodel MScammodel  
XU368 N472 N408 MScammodel MScammodel  
XU369 N465 N409 MScammodel MScammodel  
XU370 N466 N410 MScammodel MScammodel  
XU371 N467 N411 MScammodel MScammodel  
XU372 N468 N412 MScammodel MScammodel  
XU373 N469 N413 MScammodel MScammodel  
XU374 N470 N414 MScammodel MScammodel  
XU375 N471 N415 MScammodel MScammodel  
XU376 N472 N416 MScammodel MScammodel  
XU377 N465 N417 MScammodel MScammodel  
XU378 N466 N418 MScammodel MScammodel  
XU379 N467 N419 MScammodel MScammodel  
XU380 N468 N420 MScammodel MScammodel  
XU381 N469 N421 MScammodel MScammodel  
XU382 N470 N422 MScammodel MScammodel  
XU383 N471 N423 MScammodel MScammodel  
XU384 N472 N424 MScammodel MScammodel  
XU385 N465 N425 MScammodel MScammodel  
XU386 N466 N426 MScammodel MScammodel  
XU387 N467 N427 MScammodel MScammodel  
XU388 N468 N428 MScammodel MScammodel  
XU389 N469 N429 MScammodel MScammodel  
XU390 N470 N430 MScammodel MScammodel  
XU391 N471 N431 MScammodel MScammodel  
XU392 N472 N432 MScammodel MScammodel  
XU393 N465 N433 MScammodel MScammodel  
XU394 N466 N434 MScammodel MScammodel  
XU395 N467 N435 MScammodel MScammodel  
XU396 N468 N436 MScammodel MScammodel  
XU397 N469 N437 MScammodel MScammodel  
XU398 N470 N438 MScammodel MScammodel  
XU399 N471 N439 MScammodel MScammodel  
XU400 N472 N440 MScammodel MScammodel  
XU401 N465 N441 MScammodel MScammodel  
XU402 N466 N442 MScammodel MScammodel  
XU403 N467 N443 MScammodel MScammodel  
XU404 N468 N444 MScammodel MScammodel  
XU405 N469 N445 MScammodel MScammodel  
XU406 N470 N446 MScammodel MScammodel  
XU407 N471 N447 MScammodel MScammodel  
XU408 N472 N448 MScammodel MScammodel  
XU409 N465 N449 MScammodel MScammodel  
XU410 N466 N450 MScammodel MScammodel

```

XU411 N467 N451 MScammodel MScammodel
XU412 N468 N452 MScammodel MScammodel
XU413 N469 N453 MScammodel MScammodel
XU414 N470 N454 MScammodel MScammodel
XU415 N471 N455 MScammodel MScammodel
XU416 N472 N456 MScammodel MScammodel
XU417 N465 N457 MScammodel MScammodel
XU418 N466 N458 MScammodel MScammodel
XU419 N467 N459 MScammodel MScammodel
XU420 N468 N460 MScammodel MScammodel
XU421 N469 N461 MScammodel MScammodel
XU422 N470 N462 MScammodel MScammodel
XU423 N471 N463 MScammodel MScammodel
XU424 N472 N464 MScammodel MScammodel
S857 N465 N473 Vreadcol1 0 SW
S858 N466 N474 Vreadcol2 0 SW
S859 N467 N475 Vreadcol3 0 SW
S860 N468 N476 Vreadcol4 0 SW
S861 N469 N477 Vreadcol5 0 SW
S862 N470 N478 Vreadcol6 0 SW
S863 N471 N479 Vreadcol7 0 SW
S864 N472 N480 Vreadcol8 0 SW
R41 N473 0 57k
R42 N474 0 57k
R43 N475 0 57k
R44 N476 0 57k
R45 N477 0 57k
R46 N478 0 57k
R47 N479 0 57k
R48 N480 0 57k
XU425 N473 Vrefcross Vcccomp Vnncomp Voutread61 ua741
XU426 N474 Vrefcross Vcccomp Vnncomp Voutread62 ua741
XU427 N475 Vrefcross Vcccomp Vnncomp Voutread63 ua741
XU428 N476 Vrefcross Vcccomp Vnncomp Voutread64 ua741
XU429 N477 Vrefcross Vcccomp Vnncomp Voutread65 ua741
XU430 N478 Vrefcross Vcccomp Vnncomp Voutread66 ua741
XU431 N479 Vrefcross Vcccomp Vnncomp Voutread67 ua741
XU432 N480 Vrefcross Vcccomp Vnncomp Voutread68 ua741
A61 Voutread61 Voutread101 0 0 0 0 Vxored61 0 XOR td=0.27u
A62 Voutread62 Voutread102 0 0 0 0 Vxored62 0 XOR td=0.27u
A63 Voutread63 Voutread103 0 0 0 0 Vxored63 0 XOR td=0.27u
A64 Voutread64 Voutread104 0 0 0 0 Vxored64 0 XOR td=0.27u
A65 Voutread65 Voutread105 0 0 0 0 Vxored65 0 XOR td=0.27u
A66 Voutread66 Voutread106 0 0 0 0 Vxored66 0 XOR td=0.27u
A67 Voutread67 Voutread107 0 0 0 0 Vxored67 0 XOR td=0.27u
A68 Voutread68 Voutread108 0 0 0 0 Vxored68 0 XOR td=0.27u
Rin61 Vxored61 Vinput21 4k
Rin62 Vxored62 Vinput22 4k
Rin63 Vxored63 Vinput23 4k
Rin64 Vxored64 Vinput24 4k
Rin65 Vxored65 Vinput25 4k
Rin66 Vxored66 Vinput26 4k
Rin67 Vxored67 Vinput27 4k
Rin68 Vxored68 Vinput28 4k
S865 Vr N481 Vread1 0 SW
S867 N481 N482 Vread1 0 SW
S869 N482 N483 Vread1 0 SW
S871 N483 N484 Vread1 0 SW
S873 N484 N485 Vread1 0 SW
S875 N485 N486 Vread1 0 SW
S877 N486 N487 Vread1 0 SW
S879 N487 N488 Vread1 0 SW
S881 Vr N489 Vread2 0 SW
S883 N489 N490 Vread2 0 SW
S885 N490 N491 Vread2 0 SW
S887 N491 N492 Vread2 0 SW
S889 N492 N493 Vread2 0 SW
S891 N493 N494 Vread2 0 SW
S893 N494 N495 Vread2 0 SW
S895 N495 N496 Vread2 0 SW
S897 Vr N497 Vread3 0 SW
S899 N497 N498 Vread3 0 SW
S901 N498 N499 Vread3 0 SW
S903 N499 N500 Vread3 0 SW
S905 N500 N501 Vread3 0 SW
S907 N501 N502 Vread3 0 SW
S909 N502 N503 Vread3 0 SW
S911 N503 N504 Vread3 0 SW
S913 Vr N505 Vread4 0 SW
S915 N505 N506 Vread4 0 SW
S917 N506 N507 Vread4 0 SW
S919 N507 N508 Vread4 0 SW
S921 N508 N509 Vread4 0 SW
S923 N509 N510 Vread4 0 SW

```

S925 N510 N511 Vread4 0 SW  
S927 N511 N512 Vread4 0 SW  
S929 Vr N513 Vread5 0 SW  
S931 N513 N514 Vread5 0 SW  
S933 N514 N515 Vread5 0 SW  
S935 N515 N516 Vread5 0 SW  
S937 N516 N517 Vread5 0 SW  
S939 N517 N518 Vread5 0 SW  
S941 N518 N519 Vread5 0 SW  
S943 N519 N520 Vread5 0 SW  
S945 Vr N521 Vread6 0 SW  
S947 N521 N522 Vread6 0 SW  
S949 N522 N523 Vread6 0 SW  
S951 N523 N524 Vread6 0 SW  
S953 N524 N525 Vread6 0 SW  
S955 N525 N526 Vread6 0 SW  
S957 N526 N527 Vread6 0 SW  
S959 N527 N528 Vread6 0 SW  
S961 Vr N529 Vread7 0 SW  
S963 N529 N530 Vread7 0 SW  
S965 N530 N531 Vread7 0 SW  
S967 N531 N532 Vread7 0 SW  
S969 N532 N533 Vread7 0 SW  
S971 N533 N534 Vread7 0 SW  
S973 N534 N535 Vread7 0 SW  
S975 N535 N536 Vread7 0 SW  
S977 Vr N537 Vread8 0 SW  
S979 N537 N538 Vread8 0 SW  
S981 N538 N539 Vread8 0 SW  
S983 N539 N540 Vread8 0 SW  
S985 N540 N541 Vread8 0 SW  
S987 N541 N542 Vread8 0 SW  
S989 N542 N543 Vread8 0 SW  
S991 N543 N544 Vread8 0 SW  
S866 Vn N481 Vwrite 0 SW  
S868 Vn N482 Vwrite 0 SW  
S870 Vn N483 Vwrite 0 SW  
S872 Vn N484 Vwrite 0 SW  
S874 Vn N485 Vwrite 0 SW  
S876 Vn N486 Vwrite 0 SW  
S878 Vn N487 Vwrite 0 SW  
S880 Vn N488 Vwrite 0 SW  
S882 Vn N489 Vwrite 0 SW  
S884 Vn N490 Vwrite 0 SW  
S886 Vn N491 Vwrite 0 SW  
S888 Vn N492 Vwrite 0 SW  
S890 Vn N493 Vwrite 0 SW  
S892 Vn N494 Vwrite 0 SW  
S894 Vn N495 Vwrite 0 SW  
S896 Vn N496 Vwrite 0 SW  
S898 Vn N497 Vwrite 0 SW  
S900 Vn N498 Vwrite 0 SW  
S902 Vn N499 Vwrite 0 SW  
S904 Vn N500 Vwrite 0 SW  
S906 Vn N501 Vwrite 0 SW  
S908 Vn N502 Vwrite 0 SW  
S910 Vn N503 Vwrite 0 SW  
S912 Vn N504 Vwrite 0 SW  
S914 Vn N505 Vwrite 0 SW  
S916 Vn N506 Vwrite 0 SW  
S918 Vn N507 Vwrite 0 SW  
S920 Vn N508 Vwrite 0 SW  
S922 Vn N509 Vwrite 0 SW  
S924 Vp N510 Vwrite 0 SW  
S926 Vp N511 Vwrite 0 SW  
S928 Vp N512 Vwrite 0 SW  
S930 Vn N513 Vwrite 0 SW  
S932 Vn N514 Vwrite 0 SW  
S934 Vn N515 Vwrite 0 SW  
S936 Vn N516 Vwrite 0 SW  
S938 Vp N517 Vwrite 0 SW  
S940 Vn N518 Vwrite 0 SW  
S942 Vp N519 Vwrite 0 SW  
S944 Vn N520 Vwrite 0 SW  
S946 Vn N521 Vwrite 0 SW  
S948 Vn N522 Vwrite 0 SW  
S950 Vn N523 Vwrite 0 SW  
S952 Vn N524 Vwrite 0 SW  
S954 Vp N525 Vwrite 0 SW  
S956 Vp N526 Vwrite 0 SW  
S958 Vp N527 Vwrite 0 SW  
S960 Vp N528 Vwrite 0 SW  
S962 Vn N529 Vwrite 0 SW  
S964 Vn N530 Vwrite 0 SW

```

S966 Vn N531 Vwrite 0 SW
S968 Vn N532 Vwrite 0 SW
S970 Vn N533 Vwrite 0 SW
S972 Vn N534 Vwrite 0 SW
S974 Vn N535 Vwrite 0 SW
S976 Vn N536 Vwrite 0 SW
S978 Vn N537 Vwrite 0 SW
S980 Vn N538 Vwrite 0 SW
S982 Vn N539 Vwrite 0 SW
S984 Vn N540 Vwrite 0 SW
S986 Vn N541 Vwrite 0 SW
S988 Vn N542 Vwrite 0 SW
S990 Vn N543 Vwrite 0 SW
S992 Vn N544 Vwrite 0 SW
S993 0 N545 Vwrite 0 SW
S994 0 N546 Vwrite 0 SW
S995 0 N547 Vwrite 0 SW
S996 0 N548 Vwrite 0 SW
S997 0 N549 Vwrite 0 SW
S998 0 N550 Vwrite 0 SW
S999 0 N551 Vwrite 0 SW
S1000 0 N552 Vwrite 0 SW
XU433 N545 N481 MScammodel MScammodel
XU434 N546 N482 MScammodel MScammodel
XU435 N547 N483 MScammodel MScammodel
XU436 N548 N484 MScammodel MScammodel
XU437 N549 N485 MScammodel MScammodel
XU438 N550 N486 MScammodel MScammodel
XU439 N551 N487 MScammodel MScammodel
XU440 N552 N488 MScammodel MScammodel
XU441 N545 N489 MScammodel MScammodel
XU442 N546 N490 MScammodel MScammodel
XU443 N547 N491 MScammodel MScammodel
XU444 N548 N492 MScammodel MScammodel
XU445 N549 N493 MScammodel MScammodel
XU446 N550 N494 MScammodel MScammodel
XU447 N551 N495 MScammodel MScammodel
XU448 N552 N496 MScammodel MScammodel
XU449 N545 N497 MScammodel MScammodel
XU450 N546 N498 MScammodel MScammodel
XU451 N547 N499 MScammodel MScammodel
XU452 N548 N500 MScammodel MScammodel
XU453 N549 N501 MScammodel MScammodel
XU454 N550 N502 MScammodel MScammodel
XU455 N551 N503 MScammodel MScammodel
XU456 N552 N504 MScammodel MScammodel
XU457 N545 N505 MScammodel MScammodel
XU458 N546 N506 MScammodel MScammodel
XU459 N547 N507 MScammodel MScammodel
XU460 N548 N508 MScammodel MScammodel
XU461 N549 N509 MScammodel MScammodel
XU462 N550 N510 MScammodel MScammodel
XU463 N551 N511 MScammodel MScammodel
XU464 N552 N512 MScammodel MScammodel
XU465 N545 N513 MScammodel MScammodel
XU466 N546 N514 MScammodel MScammodel
XU467 N547 N515 MScammodel MScammodel
XU468 N548 N516 MScammodel MScammodel
XU469 N549 N517 MScammodel MScammodel
XU470 N550 N518 MScammodel MScammodel
XU471 N551 N519 MScammodel MScammodel
XU472 N552 N520 MScammodel MScammodel
XU473 N545 N521 MScammodel MScammodel
XU474 N546 N522 MScammodel MScammodel
XU475 N547 N523 MScammodel MScammodel
XU476 N548 N524 MScammodel MScammodel
XU477 N549 N525 MScammodel MScammodel
XU478 N550 N526 MScammodel MScammodel
XU479 N551 N527 MScammodel MScammodel
XU480 N552 N528 MScammodel MScammodel
XU481 N545 N529 MScammodel MScammodel
XU482 N546 N530 MScammodel MScammodel
XU483 N547 N531 MScammodel MScammodel
XU484 N548 N532 MScammodel MScammodel
XU485 N549 N533 MScammodel MScammodel
XU486 N550 N534 MScammodel MScammodel
XU487 N551 N535 MScammodel MScammodel
XU488 N552 N536 MScammodel MScammodel
XU489 N545 N537 MScammodel MScammodel
XU490 N546 N538 MScammodel MScammodel
XU491 N547 N539 MScammodel MScammodel
XU492 N548 N540 MScammodel MScammodel
XU493 N549 N541 MScammodel MScammodel
XU494 N550 N542 MScammodel MScammodel

```

```

XU495 N551 N543 MScammodel MScammodel
XU496 N552 N544 MScammodel MScammodel
S1001 N545 N553 Vreadcol1 0 SW
S1002 N546 N554 Vreadcol2 0 SW
S1003 N547 N555 Vreadcol3 0 SW
S1004 N548 N556 Vreadcol4 0 SW
S1005 N549 N557 Vreadcol5 0 SW
S1006 N550 N558 Vreadcol6 0 SW
S1007 N551 N559 Vreadcol7 0 SW
S1008 N552 N560 Vreadcol8 0 SW
R49 N553 0 57k
R50 N554 0 57k
R51 N555 0 57k
R52 N556 0 57k
R53 N557 0 57k
R54 N558 0 57k
R55 N559 0 57k
R56 N560 0 57k
XU497 N553 Vrefcross Vcccomp Vnncomp Voutread71 ua741
XU498 N554 Vrefcross Vcccomp Vnncomp Voutread72 ua741
XU499 N555 Vrefcross Vcccomp Vnncomp Voutread73 ua741
XU500 N556 Vrefcross Vcccomp Vnncomp Voutread74 ua741
XU501 N557 Vrefcross Vcccomp Vnncomp Voutread75 ua741
XU502 N558 Vrefcross Vcccomp Vnncomp Voutread76 ua741
XU503 N559 Vrefcross Vcccomp Vnncomp Voutread77 ua741
XU504 N560 Vrefcross Vcccomp Vnncomp Voutread78 ua741
A71 Voutread71 Voutread111 0 0 0 0 Vxored71 0 XOR td=0.27u
A72 Voutread72 Voutread112 0 0 0 0 Vxored72 0 XOR td=0.27u
A73 Voutread73 Voutread113 0 0 0 0 Vxored73 0 XOR td=0.27u
A74 Voutread74 Voutread114 0 0 0 0 Vxored74 0 XOR td=0.27u
A75 Voutread75 Voutread115 0 0 0 0 Vxored75 0 XOR td=0.27u
A76 Voutread76 Voutread116 0 0 0 0 Vxored76 0 XOR td=0.27u
A77 Voutread77 Voutread117 0 0 0 0 Vxored77 0 XOR td=0.27u
A78 Voutread78 Voutread118 0 0 0 0 Vxored78 0 XOR td=0.27u
Rin71 Vxored71 Vinput21 8k
Rin72 Vxored72 Vinput22 8k
Rin73 Vxored73 Vinput23 8k
Rin74 Vxored74 Vinput24 8k
Rin75 Vxored75 Vinput25 8k
Rin76 Vxored76 Vinput26 8k
Rin77 Vxored77 Vinput27 8k
Rin78 Vxored78 Vinput28 8k
S1009 Vr N561 Vread1 0 SW
S1011 N561 N562 Vread1 0 SW
S1013 N562 N563 Vread1 0 SW
S1015 N563 N564 Vread1 0 SW
S1017 N564 N565 Vread1 0 SW
S1019 N565 N566 Vread1 0 SW
S1021 N566 N567 Vread1 0 SW
S1023 N567 N568 Vread1 0 SW
S1025 Vr N569 Vread2 0 SW
S1027 N569 N570 Vread2 0 SW
S1029 N570 N571 Vread2 0 SW
S1031 N571 N572 Vread2 0 SW
S1033 N572 N573 Vread2 0 SW
S1035 N573 N574 Vread2 0 SW
S1037 N574 N575 Vread2 0 SW
S1039 N575 N576 Vread2 0 SW
S1041 Vr N577 Vread3 0 SW
S1043 N577 N578 Vread3 0 SW
S1045 N578 N579 Vread3 0 SW
S1047 N579 N580 Vread3 0 SW
S1049 N580 N581 Vread3 0 SW
S1051 N581 N582 Vread3 0 SW
S1053 N582 N583 Vread3 0 SW
S1055 N583 N584 Vread3 0 SW
S1057 Vr N585 Vread4 0 SW
S1059 N585 N586 Vread4 0 SW
S1061 N586 N587 Vread4 0 SW
S1063 N587 N588 Vread4 0 SW
S1065 N588 N589 Vread4 0 SW
S1067 N589 N590 Vread4 0 SW
S1069 N590 N591 Vread4 0 SW
S1071 N591 N592 Vread4 0 SW
S1073 Vr N593 Vread5 0 SW
S1075 N593 N594 Vread5 0 SW
S1077 N594 N595 Vread5 0 SW
S1079 N595 N596 Vread5 0 SW
S1081 N596 N597 Vread5 0 SW
S1083 N597 N598 Vread5 0 SW
S1085 N598 N599 Vread5 0 SW
S1087 N599 N600 Vread5 0 SW
S1089 Vr N601 Vread6 0 SW
S1091 N601 N602 Vread6 0 SW

```

S1093 N602 N603 Vread6 0 SW  
S1095 N603 N604 Vread6 0 SW  
S1097 N604 N605 Vread6 0 SW  
S1099 N605 N606 Vread6 0 SW  
S1101 N606 N607 Vread6 0 SW  
S1103 N607 N608 Vread6 0 SW  
S1105 Vr N609 Vread7 0 SW  
S1107 N609 N610 Vread7 0 SW  
S1109 N610 N611 Vread7 0 SW  
S1111 N611 N612 Vread7 0 SW  
S1113 N612 N613 Vread7 0 SW  
S1115 N613 N614 Vread7 0 SW  
S1117 N614 N615 Vread7 0 SW  
S1119 N615 N616 Vread7 0 SW  
S1121 Vr N617 Vread8 0 SW  
S1123 N617 N618 Vread8 0 SW  
S1125 N618 N619 Vread8 0 SW  
S1127 N619 N620 Vread8 0 SW  
S1129 N620 N621 Vread8 0 SW  
S1131 N621 N622 Vread8 0 SW  
S1133 N622 N623 Vread8 0 SW  
S1135 N623 N624 Vread8 0 SW  
S1010 Vp N561 Vwrite 0 SW  
S1012 Vp N562 Vwrite 0 SW  
S1014 Vp N563 Vwrite 0 SW  
S1016 Vp N564 Vwrite 0 SW  
S1018 Vp N565 Vwrite 0 SW  
S1020 Vp N566 Vwrite 0 SW  
S1022 Vp N567 Vwrite 0 SW  
S1024 Vp N568 Vwrite 0 SW  
S1026 Vp N569 Vwrite 0 SW  
S1028 Vp N570 Vwrite 0 SW  
S1030 Vp N571 Vwrite 0 SW  
S1032 Vp N572 Vwrite 0 SW  
S1034 Vp N573 Vwrite 0 SW  
S1036 Vp N574 Vwrite 0 SW  
S1038 Vp N575 Vwrite 0 SW  
S1040 Vp N576 Vwrite 0 SW  
S1042 Vp N577 Vwrite 0 SW  
S1044 Vp N578 Vwrite 0 SW  
S1046 Vp N579 Vwrite 0 SW  
S1048 Vp N580 Vwrite 0 SW  
S1050 Vp N581 Vwrite 0 SW  
S1052 Vn N582 Vwrite 0 SW  
S1054 Vp N583 Vwrite 0 SW  
S1056 Vp N584 Vwrite 0 SW  
S1058 Vp N585 Vwrite 0 SW  
S1060 Vp N586 Vwrite 0 SW  
S1062 Vp N587 Vwrite 0 SW  
S1064 Vp N588 Vwrite 0 SW  
S1066 Vp N589 Vwrite 0 SW  
S1068 Vn N590 Vwrite 0 SW  
S1070 Vp N591 Vwrite 0 SW  
S1072 Vp N592 Vwrite 0 SW  
S1074 Vp N593 Vwrite 0 SW  
S1076 Vp N594 Vwrite 0 SW  
S1078 Vp N595 Vwrite 0 SW  
S1080 Vn N596 Vwrite 0 SW  
S1082 Vn N597 Vwrite 0 SW  
S1084 Vp N598 Vwrite 0 SW  
S1086 Vn N599 Vwrite 0 SW  
S1088 Vp N600 Vwrite 0 SW  
S1090 Vp N601 Vwrite 0 SW  
S1092 Vp N602 Vwrite 0 SW  
S1094 Vp N603 Vwrite 0 SW  
S1096 Vp N604 Vwrite 0 SW  
S1098 Vp N605 Vwrite 0 SW  
S1100 Vn N606 Vwrite 0 SW  
S1102 Vp N607 Vwrite 0 SW  
S1104 Vp N608 Vwrite 0 SW  
S1106 Vp N609 Vwrite 0 SW  
S1108 Vp N610 Vwrite 0 SW  
S1110 Vp N611 Vwrite 0 SW  
S1112 Vp N612 Vwrite 0 SW  
S1114 Vp N613 Vwrite 0 SW  
S1116 Vn N614 Vwrite 0 SW  
S1118 Vp N615 Vwrite 0 SW  
S1120 Vp N616 Vwrite 0 SW  
S1122 Vp N617 Vwrite 0 SW  
S1124 Vp N618 Vwrite 0 SW  
S1126 Vp N619 Vwrite 0 SW  
S1128 Vp N620 Vwrite 0 SW  
S1130 Vp N621 Vwrite 0 SW  
S1132 Vp N622 Vwrite 0 SW

S1134 Vp N623 Vwrite 0 SW  
S1136 Vp N624 Vwrite 0 SW  
S1137 0 N625 Vwrite 0 SW  
S1138 0 N626 Vwrite 0 SW  
S1139 0 N627 Vwrite 0 SW  
S1140 0 N628 Vwrite 0 SW  
S1141 0 N629 Vwrite 0 SW  
S1142 0 N630 Vwrite 0 SW  
S1143 0 N631 Vwrite 0 SW  
S1144 0 N632 Vwrite 0 SW  
XU505 N625 N561 MScammodel MScammodel  
XU506 N626 N562 MScammodel MScammodel  
XU507 N627 N563 MScammodel MScammodel  
XU508 N628 N564 MScammodel MScammodel  
XU509 N629 N565 MScammodel MScammodel  
XU510 N630 N566 MScammodel MScammodel  
XU511 N631 N567 MScammodel MScammodel  
XU512 N632 N568 MScammodel MScammodel  
XU513 N625 N569 MScammodel MScammodel  
XU514 N626 N570 MScammodel MScammodel  
XU515 N627 N571 MScammodel MScammodel  
XU516 N628 N572 MScammodel MScammodel  
XU517 N629 N573 MScammodel MScammodel  
XU518 N630 N574 MScammodel MScammodel  
XU519 N631 N575 MScammodel MScammodel  
XU520 N632 N576 MScammodel MScammodel  
XU521 N625 N577 MScammodel MScammodel  
XU522 N626 N578 MScammodel MScammodel  
XU523 N627 N579 MScammodel MScammodel  
XU524 N628 N580 MScammodel MScammodel  
XU525 N629 N581 MScammodel MScammodel  
XU526 N630 N582 MScammodel MScammodel  
XU527 N631 N583 MScammodel MScammodel  
XU528 N632 N584 MScammodel MScammodel  
XU529 N625 N585 MScammodel MScammodel  
XU530 N626 N586 MScammodel MScammodel  
XU531 N627 N587 MScammodel MScammodel  
XU532 N628 N588 MScammodel MScammodel  
XU533 N629 N589 MScammodel MScammodel  
XU534 N630 N590 MScammodel MScammodel  
XU535 N631 N591 MScammodel MScammodel  
XU536 N632 N592 MScammodel MScammodel  
XU537 N625 N593 MScammodel MScammodel  
XU538 N626 N594 MScammodel MScammodel  
XU539 N627 N595 MScammodel MScammodel  
XU540 N628 N596 MScammodel MScammodel  
XU541 N629 N597 MScammodel MScammodel  
XU542 N630 N598 MScammodel MScammodel  
XU543 N631 N599 MScammodel MScammodel  
XU544 N632 N600 MScammodel MScammodel  
XU545 N625 N601 MScammodel MScammodel  
XU546 N626 N602 MScammodel MScammodel  
XU547 N627 N603 MScammodel MScammodel  
XU548 N628 N604 MScammodel MScammodel  
XU549 N629 N605 MScammodel MScammodel  
XU550 N630 N606 MScammodel MScammodel  
XU551 N631 N607 MScammodel MScammodel  
XU552 N632 N608 MScammodel MScammodel  
XU553 N625 N609 MScammodel MScammodel  
XU554 N626 N610 MScammodel MScammodel  
XU555 N627 N611 MScammodel MScammodel  
XU556 N628 N612 MScammodel MScammodel  
XU557 N629 N613 MScammodel MScammodel  
XU558 N630 N614 MScammodel MScammodel  
XU559 N631 N615 MScammodel MScammodel  
XU560 N632 N616 MScammodel MScammodel  
XU561 N625 N617 MScammodel MScammodel  
XU562 N626 N618 MScammodel MScammodel  
XU563 N627 N619 MScammodel MScammodel  
XU564 N628 N620 MScammodel MScammodel  
XU565 N629 N621 MScammodel MScammodel  
XU566 N630 N622 MScammodel MScammodel  
XU567 N631 N623 MScammodel MScammodel  
XU568 N632 N624 MScammodel MScammodel  
S1145 N625 N633 Vreadcol1 0 SW  
S1146 N626 N634 Vreadcol2 0 SW  
S1147 N627 N635 Vreadcol3 0 SW  
S1148 N628 N636 Vreadcol4 0 SW  
S1149 N629 N637 Vreadcol5 0 SW  
S1150 N630 N638 Vreadcol6 0 SW  
S1151 N631 N639 Vreadcol7 0 SW  
S1152 N632 N640 Vreadcol8 0 SW  
R57 N633 0 57k  
R58 N634 0 57k

```

R59 N635 0 57k
R60 N636 0 57k
R61 N637 0 57k
R62 N638 0 57k
R63 N639 0 57k
R64 N640 0 57k
XU569 N633 Vrefcross Vcccomp Vnncomp Voutread81 ua741
XU570 N634 Vrefcross Vcccomp Vnncomp Voutread82 ua741
XU571 N635 Vrefcross Vcccomp Vnncomp Voutread83 ua741
XU572 N636 Vrefcross Vcccomp Vnncomp Voutread84 ua741
XU573 N637 Vrefcross Vcccomp Vnncomp Voutread85 ua741
XU574 N638 Vrefcross Vcccomp Vnncomp Voutread86 ua741
XU575 N639 Vrefcross Vcccomp Vnncomp Voutread87 ua741
XU576 N640 Vrefcross Vcccomp Vnncomp Voutread88 ua741
A81 Voutread81 Voutread121 0 0 0 0 Vxored81 0 XOR td=0.27u
A82 Voutread82 Voutread122 0 0 0 0 Vxored82 0 XOR td=0.27u
A83 Voutread83 Voutread123 0 0 0 0 Vxored83 0 XOR td=0.27u
A84 Voutread84 Voutread124 0 0 0 0 Vxored84 0 XOR td=0.27u
A85 Voutread85 Voutread125 0 0 0 0 Vxored85 0 XOR td=0.27u
A86 Voutread86 Voutread126 0 0 0 0 Vxored86 0 XOR td=0.27u
A87 Voutread87 Voutread127 0 0 0 0 Vxored87 0 XOR td=0.27u
A88 Voutread88 Voutread128 0 0 0 0 Vxored88 0 XOR td=0.27u
Rin81 Vxored81 Vinput21 16k
Rin82 Vxored82 Vinput22 16k
Rin83 Vxored83 Vinput23 16k
Rin84 Vxored84 Vinput24 16k
Rin85 Vxored85 Vinput25 16k
Rin86 Vxored86 Vinput26 16k
Rin87 Vxored87 Vinput27 16k
Rin88 Vxored88 Vinput28 16k
S1153 Vr N641 Vread1 0 SW
S1155 N641 N642 Vread1 0 SW
S1157 N642 N643 Vread1 0 SW
S1159 N643 N644 Vread1 0 SW
S1161 N644 N645 Vread1 0 SW
S1163 N645 N646 Vread1 0 SW
S1165 N646 N647 Vread1 0 SW
S1167 N647 N648 Vread1 0 SW
S1169 Vr N649 Vread2 0 SW
S1171 N649 N650 Vread2 0 SW
S1173 N650 N651 Vread2 0 SW
S1175 N651 N652 Vread2 0 SW
S1177 N652 N653 Vread2 0 SW
S1179 N653 N654 Vread2 0 SW
S1181 N654 N655 Vread2 0 SW
S1183 N655 N656 Vread2 0 SW
S1185 Vr N657 Vread3 0 SW
S1187 N657 N658 Vread3 0 SW
S1189 N658 N659 Vread3 0 SW
S1191 N659 N660 Vread3 0 SW
S1193 N660 N661 Vread3 0 SW
S1195 N661 N662 Vread3 0 SW
S1197 N662 N663 Vread3 0 SW
S1199 N663 N664 Vread3 0 SW
S1201 Vr N665 Vread4 0 SW
S1203 N665 N666 Vread4 0 SW
S1205 N666 N667 Vread4 0 SW
S1207 N667 N668 Vread4 0 SW
S1209 N668 N669 Vread4 0 SW
S1211 N669 N670 Vread4 0 SW
S1213 N670 N671 Vread4 0 SW
S1215 N671 N672 Vread4 0 SW
S1217 Vr N673 Vread5 0 SW
S1219 N673 N674 Vread5 0 SW
S1221 N674 N675 Vread5 0 SW
S1223 N675 N676 Vread5 0 SW
S1225 N676 N677 Vread5 0 SW
S1227 N677 N678 Vread5 0 SW
S1229 N678 N679 Vread5 0 SW
S1231 N679 N680 Vread5 0 SW
S1233 Vr N681 Vread6 0 SW
S1235 N681 N682 Vread6 0 SW
S1237 N682 N683 Vread6 0 SW
S1239 N683 N684 Vread6 0 SW
S1241 N684 N685 Vread6 0 SW
S1243 N685 N686 Vread6 0 SW
S1245 N686 N687 Vread6 0 SW
S1247 N687 N688 Vread6 0 SW
S1249 Vr N689 Vread7 0 SW
S1251 N689 N690 Vread7 0 SW
S1253 N690 N691 Vread7 0 SW
S1255 N691 N692 Vread7 0 SW
S1257 N692 N693 Vread7 0 SW
S1259 N693 N694 Vread7 0 SW

```

```

S1261 N694 N695 Vread7 0 SW
S1263 N695 N696 Vread7 0 SW
S1265 Vr N697 Vread8 0 SW
S1267 N697 N698 Vread8 0 SW
S1269 N698 N699 Vread8 0 SW
S1271 N699 N700 Vread8 0 SW
S1273 N700 N701 Vread8 0 SW
S1275 N701 N702 Vread8 0 SW
S1277 N702 N703 Vread8 0 SW
S1279 N703 N704 Vread8 0 SW
S1154 Vp N641 Vwrite 0 SW
S1156 Vp N642 Vwrite 0 SW
S1158 Vp N643 Vwrite 0 SW
S1160 Vp N644 Vwrite 0 SW
S1162 Vp N645 Vwrite 0 SW
S1164 Vp N646 Vwrite 0 SW
S1166 Vp N647 Vwrite 0 SW
S1168 Vp N648 Vwrite 0 SW
S1170 Vp N649 Vwrite 0 SW
S1172 Vp N650 Vwrite 0 SW
S1174 Vp N651 Vwrite 0 SW
S1176 Vp N652 Vwrite 0 SW
S1178 Vp N653 Vwrite 0 SW
S1180 Vp N654 Vwrite 0 SW
S1182 Vp N655 Vwrite 0 SW
S1184 Vp N656 Vwrite 0 SW
S1186 Vp N657 Vwrite 0 SW
S1188 Vp N658 Vwrite 0 SW
S1190 Vp N659 Vwrite 0 SW
S1192 Vp N660 Vwrite 0 SW
S1194 Vp N661 Vwrite 0 SW
S1196 Vp N662 Vwrite 0 SW
S1198 Vp N663 Vwrite 0 SW
S1200 Vp N664 Vwrite 0 SW
S1202 Vp N665 Vwrite 0 SW
S1204 Vp N666 Vwrite 0 SW
S1206 Vp N667 Vwrite 0 SW
S1208 Vn N668 Vwrite 0 SW
S1210 Vn N669 Vwrite 0 SW
S1212 Vn N670 Vwrite 0 SW
S1214 Vp N671 Vwrite 0 SW
S1216 Vp N672 Vwrite 0 SW
S1218 Vp N673 Vwrite 0 SW
S1220 Vp N674 Vwrite 0 SW
S1222 Vn N675 Vwrite 0 SW
S1224 Vn N676 Vwrite 0 SW
S1226 Vn N677 Vwrite 0 SW
S1228 Vn N678 Vwrite 0 SW
S1230 Vn N679 Vwrite 0 SW
S1232 Vp N680 Vwrite 0 SW
S1234 Vp N681 Vwrite 0 SW
S1236 Vp N682 Vwrite 0 SW
S1238 Vn N683 Vwrite 0 SW
S1240 Vn N684 Vwrite 0 SW
S1242 Vn N685 Vwrite 0 SW
S1244 Vn N686 Vwrite 0 SW
S1246 Vn N687 Vwrite 0 SW
S1248 Vp N688 Vwrite 0 SW
S1250 Vp N689 Vwrite 0 SW
S1252 Vp N690 Vwrite 0 SW
S1254 Vn N691 Vwrite 0 SW
S1256 Vn N692 Vwrite 0 SW
S1258 Vn N693 Vwrite 0 SW
S1260 Vn N694 Vwrite 0 SW
S1262 Vn N695 Vwrite 0 SW
S1264 Vp N696 Vwrite 0 SW
S1266 Vp N697 Vwrite 0 SW
S1268 Vp N698 Vwrite 0 SW
S1270 Vp N699 Vwrite 0 SW
S1272 Vn N700 Vwrite 0 SW
S1274 Vn N701 Vwrite 0 SW
S1276 Vn N702 Vwrite 0 SW
S1278 Vp N703 Vwrite 0 SW
S1280 Vp N704 Vwrite 0 SW
S1281 0 N705 Vwrite 0 SW
S1282 0 N706 Vwrite 0 SW
S1283 0 N707 Vwrite 0 SW
S1284 0 N708 Vwrite 0 SW
S1285 0 N709 Vwrite 0 SW
S1286 0 N710 Vwrite 0 SW
S1287 0 N711 Vwrite 0 SW
S1288 0 N712 Vwrite 0 SW
XU577 N705 N641 MScammodel MScammodel
XU578 N706 N642 MScammodel MScammodel

```

XU579	N707	N643	MScammodel	MScammodel
XU580	N708	N644	MScammodel	MScammodel
XU581	N709	N645	MScammodel	MScammodel
XU582	N710	N646	MScammodel	MScammodel
XU583	N711	N647	MScammodel	MScammodel
XU584	N712	N648	MScammodel	MScammodel
XU585	N705	N649	MScammodel	MScammodel
XU586	N706	N650	MScammodel	MScammodel
XU587	N707	N651	MScammodel	MScammodel
XU588	N708	N652	MScammodel	MScammodel
XU589	N709	N653	MScammodel	MScammodel
XU590	N710	N654	MScammodel	MScammodel
XU591	N711	N655	MScammodel	MScammodel
XU592	N712	N656	MScammodel	MScammodel
XU593	N705	N657	MScammodel	MScammodel
XU594	N706	N658	MScammodel	MScammodel
XU595	N707	N659	MScammodel	MScammodel
XU596	N708	N660	MScammodel	MScammodel
XU597	N709	N661	MScammodel	MScammodel
XU598	N710	N662	MScammodel	MScammodel
XU599	N711	N663	MScammodel	MScammodel
XU600	N712	N664	MScammodel	MScammodel
XU601	N705	N665	MScammodel	MScammodel
XU602	N706	N666	MScammodel	MScammodel
XU603	N707	N667	MScammodel	MScammodel
XU604	N708	N668	MScammodel	MScammodel
XU605	N709	N669	MScammodel	MScammodel
XU606	N710	N670	MScammodel	MScammodel
XU607	N711	N671	MScammodel	MScammodel
XU608	N712	N672	MScammodel	MScammodel
XU609	N705	N673	MScammodel	MScammodel
XU610	N706	N674	MScammodel	MScammodel
XU611	N707	N675	MScammodel	MScammodel
XU612	N708	N676	MScammodel	MScammodel
XU613	N709	N677	MScammodel	MScammodel
XU614	N710	N678	MScammodel	MScammodel
XU615	N711	N679	MScammodel	MScammodel
XU616	N712	N680	MScammodel	MScammodel
XU617	N705	N681	MScammodel	MScammodel
XU618	N706	N682	MScammodel	MScammodel
XU619	N707	N683	MScammodel	MScammodel
XU620	N708	N684	MScammodel	MScammodel
XU621	N709	N685	MScammodel	MScammodel
XU622	N710	N686	MScammodel	MScammodel
XU623	N711	N687	MScammodel	MScammodel
XU624	N712	N688	MScammodel	MScammodel
XU625	N705	N689	MScammodel	MScammodel
XU626	N706	N690	MScammodel	MScammodel
XU627	N707	N691	MScammodel	MScammodel
XU628	N708	N692	MScammodel	MScammodel
XU629	N709	N693	MScammodel	MScammodel
XU630	N710	N694	MScammodel	MScammodel
XU631	N711	N695	MScammodel	MScammodel
XU632	N712	N696	MScammodel	MScammodel
XU633	N705	N697	MScammodel	MScammodel
XU634	N706	N698	MScammodel	MScammodel
XU635	N707	N699	MScammodel	MScammodel
XU636	N708	N700	MScammodel	MScammodel
XU637	N709	N701	MScammodel	MScammodel
XU638	N710	N702	MScammodel	MScammodel
XU639	N711	N703	MScammodel	MScammodel
XU640	N712	N704	MScammodel	MScammodel
S1289	N705	N713	Vreadcol1	0 SW
S1290	N706	N714	Vreadcol2	0 SW
S1291	N707	N715	Vreadcol3	0 SW
S1292	N708	N716	Vreadcol4	0 SW
S1293	N709	N717	Vreadcol5	0 SW
S1294	N710	N718	Vreadcol6	0 SW
S1295	N711	N719	Vreadcol7	0 SW
S1296	N712	N720	Vreadcol8	0 SW
R65	N713	0	57k	
R66	N714	0	57k	
R67	N715	0	57k	
R68	N716	0	57k	
R69	N717	0	57k	
R70	N718	0	57k	
R71	N719	0	57k	
R72	N720	0	57k	
XU641	N713	Vrefcross	Vcccomp	Vnncomp Voutread91 ua741
XU642	N714	Vrefcross	Vcccomp	Vnncomp Voutread92 ua741
XU643	N715	Vrefcross	Vcccomp	Vnncomp Voutread93 ua741
XU644	N716	Vrefcross	Vcccomp	Vnncomp Voutread94 ua741
XU645	N717	Vrefcross	Vcccomp	Vnncomp Voutread95 ua741
XU646	N718	Vrefcross	Vcccomp	Vnncomp Voutread96 ua741

```

XU647 N719 Vrefcross Vcccomp Vnncomp Voutread97 ua741
XU648 N720 Vrefcross Vcccomp Vnncomp Voutread98 ua741
S1297 Vr N721 Vread1 0 SW
S1299 N721 N722 Vread1 0 SW
S1301 N722 N723 Vread1 0 SW
S1303 N723 N724 Vread1 0 SW
S1305 N724 N725 Vread1 0 SW
S1307 N725 N726 Vread1 0 SW
S1309 N726 N727 Vread1 0 SW
S1311 N727 N728 Vread1 0 SW
S1313 Vr N729 Vread2 0 SW
S1315 N729 N730 Vread2 0 SW
S1317 N730 N731 Vread2 0 SW
S1319 N731 N732 Vread2 0 SW
S1321 N732 N733 Vread2 0 SW
S1323 N733 N734 Vread2 0 SW
S1325 N734 N735 Vread2 0 SW
S1327 N735 N736 Vread2 0 SW
S1329 Vr N737 Vread3 0 SW
S1331 N737 N738 Vread3 0 SW
S1333 N738 N739 Vread3 0 SW
S1335 N739 N740 Vread3 0 SW
S1337 N740 N741 Vread3 0 SW
S1339 N741 N742 Vread3 0 SW
S1341 N742 N743 Vread3 0 SW
S1343 N743 N744 Vread3 0 SW
S1345 Vr N745 Vread4 0 SW
S1347 N745 N746 Vread4 0 SW
S1349 N746 N747 Vread4 0 SW
S1351 N747 N748 Vread4 0 SW
S1353 N748 N749 Vread4 0 SW
S1355 N749 N750 Vread4 0 SW
S1357 N750 N751 Vread4 0 SW
S1359 N751 N752 Vread4 0 SW
S1361 Vr N753 Vread5 0 SW
S1363 N753 N754 Vread5 0 SW
S1365 N754 N755 Vread5 0 SW
S1367 N755 N756 Vread5 0 SW
S1369 N756 N757 Vread5 0 SW
S1371 N757 N758 Vread5 0 SW
S1373 N758 N759 Vread5 0 SW
S1375 N759 N760 Vread5 0 SW
S1377 Vr N761 Vread6 0 SW
S1379 N761 N762 Vread6 0 SW
S1381 N762 N763 Vread6 0 SW
S1383 N763 N764 Vread6 0 SW
S1385 N764 N765 Vread6 0 SW
S1387 N765 N766 Vread6 0 SW
S1389 N766 N767 Vread6 0 SW
S1391 N767 N768 Vread6 0 SW
S1393 Vr N769 Vread7 0 SW
S1395 N769 N770 Vread7 0 SW
S1397 N770 N771 Vread7 0 SW
S1399 N771 N772 Vread7 0 SW
S1401 N772 N773 Vread7 0 SW
S1403 N773 N774 Vread7 0 SW
S1405 N774 N775 Vread7 0 SW
S1407 N775 N776 Vread7 0 SW
S1409 Vr N777 Vread8 0 SW
S1411 N777 N778 Vread8 0 SW
S1413 N778 N779 Vread8 0 SW
S1415 N779 N780 Vread8 0 SW
S1417 N780 N781 Vread8 0 SW
S1419 N781 N782 Vread8 0 SW
S1421 N782 N783 Vread8 0 SW
S1423 N783 N784 Vread8 0 SW
S1298 Vn N721 Vwrite 0 SW
S1300 Vn N722 Vwrite 0 SW
S1302 Vn N723 Vwrite 0 SW
S1304 Vn N724 Vwrite 0 SW
S1306 Vn N725 Vwrite 0 SW
S1308 Vn N726 Vwrite 0 SW
S1310 Vn N727 Vwrite 0 SW
S1312 Vn N728 Vwrite 0 SW
S1314 Vn N729 Vwrite 0 SW
S1316 Vn N730 Vwrite 0 SW
S1318 Vn N731 Vwrite 0 SW
S1320 Vn N732 Vwrite 0 SW
S1322 Vn N733 Vwrite 0 SW
S1324 Vn N734 Vwrite 0 SW
S1326 Vn N735 Vwrite 0 SW
S1328 Vn N736 Vwrite 0 SW
S1330 Vn N737 Vwrite 0 SW
S1332 Vn N738 Vwrite 0 SW

```

S1334 Vn N739 Vwrite 0 SW  
S1336 Vn N740 Vwrite 0 SW  
S1338 Vn N741 Vwrite 0 SW  
S1340 Vn N742 Vwrite 0 SW  
S1342 Vn N743 Vwrite 0 SW  
S1344 Vn N744 Vwrite 0 SW  
S1346 Vn N745 Vwrite 0 SW  
S1348 Vn N746 Vwrite 0 SW  
S1350 Vn N747 Vwrite 0 SW  
S1352 Vp N748 Vwrite 0 SW  
S1354 Vp N749 Vwrite 0 SW  
S1356 Vp N750 Vwrite 0 SW  
S1358 Vn N751 Vwrite 0 SW  
S1360 Vn N752 Vwrite 0 SW  
S1362 Vn N753 Vwrite 0 SW  
S1364 Vn N754 Vwrite 0 SW  
S1366 Vp N755 Vwrite 0 SW  
S1368 Vn N756 Vwrite 0 SW  
S1370 Vn N757 Vwrite 0 SW  
S1372 Vn N758 Vwrite 0 SW  
S1374 Vp N759 Vwrite 0 SW  
S1376 Vn N760 Vwrite 0 SW  
S1378 Vn N761 Vwrite 0 SW  
S1380 Vn N762 Vwrite 0 SW  
S1382 Vp N763 Vwrite 0 SW  
S1384 Vn N764 Vwrite 0 SW  
S1386 Vn N765 Vwrite 0 SW  
S1388 Vn N766 Vwrite 0 SW  
S1390 Vp N767 Vwrite 0 SW  
S1392 Vn N768 Vwrite 0 SW  
S1394 Vn N769 Vwrite 0 SW  
S1396 Vn N770 Vwrite 0 SW  
S1398 Vp N771 Vwrite 0 SW  
S1400 Vn N772 Vwrite 0 SW  
S1402 Vn N773 Vwrite 0 SW  
S1404 Vn N774 Vwrite 0 SW  
S1406 Vp N775 Vwrite 0 SW  
S1408 Vn N776 Vwrite 0 SW  
S1410 Vn N777 Vwrite 0 SW  
S1412 Vn N778 Vwrite 0 SW  
S1414 Vn N779 Vwrite 0 SW  
S1416 Vp N780 Vwrite 0 SW  
S1418 Vp N781 Vwrite 0 SW  
S1420 Vp N782 Vwrite 0 SW  
S1422 Vn N783 Vwrite 0 SW  
S1424 Vn N784 Vwrite 0 SW  
S1425 0 N785 Vwrite 0 SW  
S1426 0 N786 Vwrite 0 SW  
S1427 0 N787 Vwrite 0 SW  
S1428 0 N788 Vwrite 0 SW  
S1429 0 N789 Vwrite 0 SW  
S1430 0 N790 Vwrite 0 SW  
S1431 0 N791 Vwrite 0 SW  
S1432 0 N792 Vwrite 0 SW  
XU649 N785 N721 MScammodel MScammodel  
XU650 N786 N722 MScammodel MScammodel  
XU651 N787 N723 MScammodel MScammodel  
XU652 N788 N724 MScammodel MScammodel  
XU653 N789 N725 MScammodel MScammodel  
XU654 N790 N726 MScammodel MScammodel  
XU655 N791 N727 MScammodel MScammodel  
XU656 N792 N728 MScammodel MScammodel  
XU657 N785 N729 MScammodel MScammodel  
XU658 N786 N730 MScammodel MScammodel  
XU659 N787 N731 MScammodel MScammodel  
XU660 N788 N732 MScammodel MScammodel  
XU661 N789 N733 MScammodel MScammodel  
XU662 N790 N734 MScammodel MScammodel  
XU663 N791 N735 MScammodel MScammodel  
XU664 N792 N736 MScammodel MScammodel  
XU665 N785 N737 MScammodel MScammodel  
XU666 N786 N738 MScammodel MScammodel  
XU667 N787 N739 MScammodel MScammodel  
XU668 N788 N740 MScammodel MScammodel  
XU669 N789 N741 MScammodel MScammodel  
XU670 N790 N742 MScammodel MScammodel  
XU671 N791 N743 MScammodel MScammodel  
XU672 N792 N744 MScammodel MScammodel  
XU673 N785 N745 MScammodel MScammodel  
XU674 N786 N746 MScammodel MScammodel  
XU675 N787 N747 MScammodel MScammodel  
XU676 N788 N748 MScammodel MScammodel  
XU677 N789 N749 MScammodel MScammodel  
XU678 N790 N750 MScammodel MScammodel

XU679 N791 N751 MScammodel MScammodel  
XU680 N792 N752 MScammodel MScammodel  
XU681 N785 N753 MScammodel MScammodel  
XU682 N786 N754 MScammodel MScammodel  
XU683 N787 N755 MScammodel MScammodel  
XU684 N788 N756 MScammodel MScammodel  
XU685 N789 N757 MScammodel MScammodel  
XU686 N790 N758 MScammodel MScammodel  
XU687 N791 N759 MScammodel MScammodel  
XU688 N792 N760 MScammodel MScammodel  
XU689 N785 N761 MScammodel MScammodel  
XU690 N786 N762 MScammodel MScammodel  
XU691 N787 N763 MScammodel MScammodel  
XU692 N788 N764 MScammodel MScammodel  
XU693 N789 N765 MScammodel MScammodel  
XU694 N790 N766 MScammodel MScammodel  
XU695 N791 N767 MScammodel MScammodel  
XU696 N792 N768 MScammodel MScammodel  
XU697 N785 N769 MScammodel MScammodel  
XU698 N786 N770 MScammodel MScammodel  
XU699 N787 N771 MScammodel MScammodel  
XU700 N788 N772 MScammodel MScammodel  
XU701 N789 N773 MScammodel MScammodel  
XU702 N790 N774 MScammodel MScammodel  
XU703 N791 N775 MScammodel MScammodel  
XU704 N792 N776 MScammodel MScammodel  
XU705 N785 N777 MScammodel MScammodel  
XU706 N786 N778 MScammodel MScammodel  
XU707 N787 N779 MScammodel MScammodel  
XU708 N788 N780 MScammodel MScammodel  
XU709 N789 N781 MScammodel MScammodel  
XU710 N790 N782 MScammodel MScammodel  
XU711 N791 N783 MScammodel MScammodel  
XU712 N792 N784 MScammodel MScammodel  
S1433 N785 N793 Vreadcol1 0 SW  
S1434 N786 N794 Vreadcol2 0 SW  
S1435 N787 N795 Vreadcol3 0 SW  
S1436 N788 N796 Vreadcol4 0 SW  
S1437 N789 N797 Vreadcol5 0 SW  
S1438 N790 N798 Vreadcol6 0 SW  
S1439 N791 N799 Vreadcol7 0 SW  
S1440 N792 N800 Vreadcol8 0 SW  
R73 N793 0 57k  
R74 N794 0 57k  
R75 N795 0 57k  
R76 N796 0 57k  
R77 N797 0 57k  
R78 N798 0 57k  
R79 N799 0 57k  
R80 N800 0 57k  
XU713 N793 Vrefcross Vcccomp Vnncomp Voutread101 ua741  
XU714 N794 Vrefcross Vcccomp Vnncomp Voutread102 ua741  
XU715 N795 Vrefcross Vcccomp Vnncomp Voutread103 ua741  
XU716 N796 Vrefcross Vcccomp Vnncomp Voutread104 ua741  
XU717 N797 Vrefcross Vcccomp Vnncomp Voutread105 ua741  
XU718 N798 Vrefcross Vcccomp Vnncomp Voutread106 ua741  
XU719 N799 Vrefcross Vcccomp Vnncomp Voutread107 ua741  
XU720 N800 Vrefcross Vcccomp Vnncomp Voutread108 ua741  
S1441 Vr N801 Vread1 0 SW  
S1443 N801 N802 Vread1 0 SW  
S1445 N802 N803 Vread1 0 SW  
S1447 N803 N804 Vread1 0 SW  
S1449 N804 N805 Vread1 0 SW  
S1451 N805 N806 Vread1 0 SW  
S1453 N806 N807 Vread1 0 SW  
S1455 N807 N808 Vread1 0 SW  
S1457 Vr N809 Vread2 0 SW  
S1459 N809 N810 Vread2 0 SW  
S1461 N810 N811 Vread2 0 SW  
S1463 N811 N812 Vread2 0 SW  
S1465 N812 N813 Vread2 0 SW  
S1467 N813 N814 Vread2 0 SW  
S1469 N814 N815 Vread2 0 SW  
S1471 N815 N816 Vread2 0 SW  
S1473 Vr N817 Vread3 0 SW  
S1475 N817 N818 Vread3 0 SW  
S1477 N818 N819 Vread3 0 SW  
S1479 N819 N820 Vread3 0 SW  
S1481 N820 N821 Vread3 0 SW  
S1483 N821 N822 Vread3 0 SW  
S1485 N822 N823 Vread3 0 SW  
S1487 N823 N824 Vread3 0 SW  
S1489 Vr N825 Vread4 0 SW  
S1491 N825 N826 Vread4 0 SW

S1493 N826 N827 Vread4 0 SW  
S1495 N827 N828 Vread4 0 SW  
S1497 N828 N829 Vread4 0 SW  
S1499 N829 N830 Vread4 0 SW  
S1501 N830 N831 Vread4 0 SW  
S1503 N831 N832 Vread4 0 SW  
S1505 Vr N833 Vread5 0 SW  
S1507 N833 N834 Vread5 0 SW  
S1509 N834 N835 Vread5 0 SW  
S1511 N835 N836 Vread5 0 SW  
S1513 N836 N837 Vread5 0 SW  
S1515 N837 N838 Vread5 0 SW  
S1517 N838 N839 Vread5 0 SW  
S1519 N839 N840 Vread5 0 SW  
S1521 Vr N841 Vread6 0 SW  
S1523 N841 N842 Vread6 0 SW  
S1525 N842 N843 Vread6 0 SW  
S1527 N843 N844 Vread6 0 SW  
S1529 N844 N845 Vread6 0 SW  
S1531 N845 N846 Vread6 0 SW  
S1533 N846 N847 Vread6 0 SW  
S1535 N847 N848 Vread6 0 SW  
S1537 Vr N849 Vread7 0 SW  
S1539 N849 N850 Vread7 0 SW  
S1541 N850 N851 Vread7 0 SW  
S1543 N851 N852 Vread7 0 SW  
S1545 N852 N853 Vread7 0 SW  
S1547 N853 N854 Vread7 0 SW  
S1549 N854 N855 Vread7 0 SW  
S1551 N855 N856 Vread7 0 SW  
S1553 Vr N857 Vread8 0 SW  
S1555 N857 N858 Vread8 0 SW  
S1557 N858 N859 Vread8 0 SW  
S1559 N859 N860 Vread8 0 SW  
S1561 N860 N861 Vread8 0 SW  
S1563 N861 N862 Vread8 0 SW  
S1565 N862 N863 Vread8 0 SW  
S1567 N863 N864 Vread8 0 SW  
S1442 Vn N801 Vwrite 0 SW  
S1444 Vn N802 Vwrite 0 SW  
S1446 Vn N803 Vwrite 0 SW  
S1448 Vn N804 Vwrite 0 SW  
S1450 Vn N805 Vwrite 0 SW  
S1452 Vn N806 Vwrite 0 SW  
S1454 Vn N807 Vwrite 0 SW  
S1456 Vn N808 Vwrite 0 SW  
S1458 Vn N809 Vwrite 0 SW  
S1460 Vn N810 Vwrite 0 SW  
S1462 Vn N811 Vwrite 0 SW  
S1464 Vn N812 Vwrite 0 SW  
S1466 Vn N813 Vwrite 0 SW  
S1468 Vn N814 Vwrite 0 SW  
S1470 Vn N815 Vwrite 0 SW  
S1472 Vn N816 Vwrite 0 SW  
S1474 Vn N817 Vwrite 0 SW  
S1476 Vn N818 Vwrite 0 SW  
S1478 Vn N819 Vwrite 0 SW  
S1480 Vn N820 Vwrite 0 SW  
S1482 Vn N821 Vwrite 0 SW  
S1484 Vn N822 Vwrite 0 SW  
S1486 Vn N823 Vwrite 0 SW  
S1488 Vn N824 Vwrite 0 SW  
S1490 Vn N825 Vwrite 0 SW  
S1492 Vn N826 Vwrite 0 SW  
S1494 Vn N827 Vwrite 0 SW  
S1496 Vn N828 Vwrite 0 SW  
S1498 Vp N829 Vwrite 0 SW  
S1500 Vn N830 Vwrite 0 SW  
S1502 Vn N831 Vwrite 0 SW  
S1504 Vp N832 Vwrite 0 SW  
S1506 Vn N833 Vwrite 0 SW  
S1508 Vn N834 Vwrite 0 SW  
S1510 Vn N835 Vwrite 0 SW  
S1512 Vp N836 Vwrite 0 SW  
S1514 Vp N837 Vwrite 0 SW  
S1516 Vp N838 Vwrite 0 SW  
S1518 Vn N839 Vwrite 0 SW  
S1520 Vn N840 Vwrite 0 SW  
S1522 Vn N841 Vwrite 0 SW  
S1524 Vn N842 Vwrite 0 SW  
S1526 Vp N843 Vwrite 0 SW  
S1528 Vp N844 Vwrite 0 SW  
S1530 Vp N845 Vwrite 0 SW  
S1532 Vp N846 Vwrite 0 SW

S1534 Vp N847 Vwrite 0 SW  
S1536 Vn N848 Vwrite 0 SW  
S1538 Vn N849 Vwrite 0 SW  
S1540 Vn N850 Vwrite 0 SW  
S1542 Vn N851 Vwrite 0 SW  
S1544 Vp N852 Vwrite 0 SW  
S1546 Vp N853 Vwrite 0 SW  
S1548 Vp N854 Vwrite 0 SW  
S1550 Vn N855 Vwrite 0 SW  
S1552 Vn N856 Vwrite 0 SW  
S1554 Vn N857 Vwrite 0 SW  
S1556 Vp N858 Vwrite 0 SW  
S1558 Vn N859 Vwrite 0 SW  
S1560 Vn N860 Vwrite 0 SW  
S1562 Vp N861 Vwrite 0 SW  
S1564 Vn N862 Vwrite 0 SW  
S1566 Vn N863 Vwrite 0 SW  
S1568 Vp N864 Vwrite 0 SW  
S1569 0 N865 Vwrite 0 SW  
S1570 0 N866 Vwrite 0 SW  
S1571 0 N867 Vwrite 0 SW  
S1572 0 N868 Vwrite 0 SW  
S1573 0 N869 Vwrite 0 SW  
S1574 0 N870 Vwrite 0 SW  
S1575 0 N871 Vwrite 0 SW  
S1576 0 N872 Vwrite 0 SW  
XU721 N865 N801 MScammodel MScammodel  
XU722 N866 N802 MScammodel MScammodel  
XU723 N867 N803 MScammodel MScammodel  
XU724 N868 N804 MScammodel MScammodel  
XU725 N869 N805 MScammodel MScammodel  
XU726 N870 N806 MScammodel MScammodel  
XU727 N871 N807 MScammodel MScammodel  
XU728 N872 N808 MScammodel MScammodel  
XU729 N865 N809 MScammodel MScammodel  
XU730 N866 N810 MScammodel MScammodel  
XU731 N867 N811 MScammodel MScammodel  
XU732 N868 N812 MScammodel MScammodel  
XU733 N869 N813 MScammodel MScammodel  
XU734 N870 N814 MScammodel MScammodel  
XU735 N871 N815 MScammodel MScammodel  
XU736 N872 N816 MScammodel MScammodel  
XU737 N865 N817 MScammodel MScammodel  
XU738 N866 N818 MScammodel MScammodel  
XU739 N867 N819 MScammodel MScammodel  
XU740 N868 N820 MScammodel MScammodel  
XU741 N869 N821 MScammodel MScammodel  
XU742 N870 N822 MScammodel MScammodel  
XU743 N871 N823 MScammodel MScammodel  
XU744 N872 N824 MScammodel MScammodel  
XU745 N865 N825 MScammodel MScammodel  
XU746 N866 N826 MScammodel MScammodel  
XU747 N867 N827 MScammodel MScammodel  
XU748 N868 N828 MScammodel MScammodel  
XU749 N869 N829 MScammodel MScammodel  
XU750 N870 N830 MScammodel MScammodel  
XU751 N871 N831 MScammodel MScammodel  
XU752 N872 N832 MScammodel MScammodel  
XU753 N865 N833 MScammodel MScammodel  
XU754 N866 N834 MScammodel MScammodel  
XU755 N867 N835 MScammodel MScammodel  
XU756 N868 N836 MScammodel MScammodel  
XU757 N869 N837 MScammodel MScammodel  
XU758 N870 N838 MScammodel MScammodel  
XU759 N871 N839 MScammodel MScammodel  
XU760 N872 N840 MScammodel MScammodel  
XU761 N865 N841 MScammodel MScammodel  
XU762 N866 N842 MScammodel MScammodel  
XU763 N867 N843 MScammodel MScammodel  
XU764 N868 N844 MScammodel MScammodel  
XU765 N869 N845 MScammodel MScammodel  
XU766 N870 N846 MScammodel MScammodel  
XU767 N871 N847 MScammodel MScammodel  
XU768 N872 N848 MScammodel MScammodel  
XU769 N865 N849 MScammodel MScammodel  
XU770 N866 N850 MScammodel MScammodel  
XU771 N867 N851 MScammodel MScammodel  
XU772 N868 N852 MScammodel MScammodel  
XU773 N869 N853 MScammodel MScammodel  
XU774 N870 N854 MScammodel MScammodel  
XU775 N871 N855 MScammodel MScammodel  
XU776 N872 N856 MScammodel MScammodel  
XU777 N865 N857 MScammodel MScammodel  
XU778 N866 N858 MScammodel MScammodel

XU779 N867 N859 MScammodel MScammodel  
XU780 N868 N860 MScammodel MScammodel  
XU781 N869 N861 MScammodel MScammodel  
XU782 N870 N862 MScammodel MScammodel  
XU783 N871 N863 MScammodel MScammodel  
XU784 N872 N864 MScammodel MScammodel  
S1577 N865 N873 Vreadcol1 0 SW  
S1578 N866 N874 Vreadcol2 0 SW  
S1579 N867 N875 Vreadcol3 0 SW  
S1580 N868 N876 Vreadcol4 0 SW  
S1581 N869 N877 Vreadcol5 0 SW  
S1582 N870 N878 Vreadcol6 0 SW  
S1583 N871 N879 Vreadcol7 0 SW  
S1584 N872 N880 Vreadcol8 0 SW  
R81 N873 0 57k  
R82 N874 0 57k  
R83 N875 0 57k  
R84 N876 0 57k  
R85 N877 0 57k  
R86 N878 0 57k  
R87 N879 0 57k  
R88 N880 0 57k  
XU785 N873 Vrefcross Vcccomp Vnncomp Voutread111 ua741  
XU786 N874 Vrefcross Vcccomp Vnncomp Voutread112 ua741  
XU787 N875 Vrefcross Vcccomp Vnncomp Voutread113 ua741  
XU788 N876 Vrefcross Vcccomp Vnncomp Voutread114 ua741  
XU789 N877 Vrefcross Vcccomp Vnncomp Voutread115 ua741  
XU790 N878 Vrefcross Vcccomp Vnncomp Voutread116 ua741  
XU791 N879 Vrefcross Vcccomp Vnncomp Voutread117 ua741  
XU792 N880 Vrefcross Vcccomp Vnncomp Voutread118 ua741  
S1585 Vr N881 Vread1 0 SW  
S1587 N881 N882 Vread1 0 SW  
S1589 N882 N883 Vread1 0 SW  
S1591 N883 N884 Vread1 0 SW  
S1593 N884 N885 Vread1 0 SW  
S1595 N885 N886 Vread1 0 SW  
S1597 N886 N887 Vread1 0 SW  
S1599 N887 N888 Vread1 0 SW  
S1601 Vr N889 Vread2 0 SW  
S1603 N889 N890 Vread2 0 SW  
S1605 N890 N891 Vread2 0 SW  
S1607 N891 N892 Vread2 0 SW  
S1609 N892 N893 Vread2 0 SW  
S1611 N893 N894 Vread2 0 SW  
S1613 N894 N895 Vread2 0 SW  
S1615 N895 N896 Vread2 0 SW  
S1617 Vr N897 Vread3 0 SW  
S1619 N897 N898 Vread3 0 SW  
S1621 N898 N899 Vread3 0 SW  
S1623 N899 N900 Vread3 0 SW  
S1625 N900 N901 Vread3 0 SW  
S1627 N901 N902 Vread3 0 SW  
S1629 N902 N903 Vread3 0 SW  
S1631 N903 N904 Vread3 0 SW  
S1633 Vr N905 Vread4 0 SW  
S1635 N905 N906 Vread4 0 SW  
S1637 N906 N907 Vread4 0 SW  
S1639 N907 N908 Vread4 0 SW  
S1641 N908 N909 Vread4 0 SW  
S1643 N909 N910 Vread4 0 SW  
S1645 N910 N911 Vread4 0 SW  
S1647 N911 N912 Vread4 0 SW  
S1649 Vr N913 Vread5 0 SW  
S1651 N913 N914 Vread5 0 SW  
S1653 N914 N915 Vread5 0 SW  
S1655 N915 N916 Vread5 0 SW  
S1657 N916 N917 Vread5 0 SW  
S1659 N917 N918 Vread5 0 SW  
S1661 N918 N919 Vread5 0 SW  
S1663 N919 N920 Vread5 0 SW  
S1665 Vr N921 Vread6 0 SW  
S1667 N921 N922 Vread6 0 SW  
S1669 N922 N923 Vread6 0 SW  
S1671 N923 N924 Vread6 0 SW  
S1673 N924 N925 Vread6 0 SW  
S1675 N925 N926 Vread6 0 SW  
S1677 N926 N927 Vread6 0 SW  
S1679 N927 N928 Vread6 0 SW  
S1681 Vr N929 Vread7 0 SW  
S1683 N929 N930 Vread7 0 SW  
S1685 N930 N931 Vread7 0 SW  
S1687 N931 N932 Vread7 0 SW  
S1689 N932 N933 Vread7 0 SW  
S1691 N933 N934 Vread7 0 SW

S1693 N934 N935 Vread7 0 SW  
S1695 N935 N936 Vread7 0 SW  
S1697 Vr N937 Vread8 0 SW  
S1699 N937 N938 Vread8 0 SW  
S1701 N938 N939 Vread8 0 SW  
S1703 N939 N940 Vread8 0 SW  
S1705 N940 N941 Vread8 0 SW  
S1707 N941 N942 Vread8 0 SW  
S1709 N942 N943 Vread8 0 SW  
S1711 N943 N944 Vread8 0 SW  
S1586 Vp N881 Vwrite 0 SW  
S1588 Vp N882 Vwrite 0 SW  
S1590 Vp N883 Vwrite 0 SW  
S1592 Vp N884 Vwrite 0 SW  
S1594 Vp N885 Vwrite 0 SW  
S1596 Vp N886 Vwrite 0 SW  
S1598 Vp N887 Vwrite 0 SW  
S1600 Vp N888 Vwrite 0 SW  
S1602 Vp N889 Vwrite 0 SW  
S1604 Vp N890 Vwrite 0 SW  
S1606 Vp N891 Vwrite 0 SW  
S1608 Vp N892 Vwrite 0 SW  
S1610 Vp N893 Vwrite 0 SW  
S1612 Vp N894 Vwrite 0 SW  
S1614 Vp N895 Vwrite 0 SW  
S1616 Vp N896 Vwrite 0 SW  
S1618 Vp N897 Vwrite 0 SW  
S1620 Vp N898 Vwrite 0 SW  
S1622 Vp N899 Vwrite 0 SW  
S1624 Vp N900 Vwrite 0 SW  
S1626 Vn N901 Vwrite 0 SW  
S1628 Vp N902 Vwrite 0 SW  
S1630 Vp N903 Vwrite 0 SW  
S1632 Vp N904 Vwrite 0 SW  
S1634 Vp N905 Vwrite 0 SW  
S1636 Vp N906 Vwrite 0 SW  
S1638 Vn N907 Vwrite 0 SW  
S1640 Vn N908 Vwrite 0 SW  
S1642 Vn N909 Vwrite 0 SW  
S1644 Vn N910 Vwrite 0 SW  
S1646 Vn N911 Vwrite 0 SW  
S1648 Vp N912 Vwrite 0 SW  
S1650 Vp N913 Vwrite 0 SW  
S1652 Vp N914 Vwrite 0 SW  
S1654 Vn N915 Vwrite 0 SW  
S1656 Vp N916 Vwrite 0 SW  
S1658 Vp N917 Vwrite 0 SW  
S1660 Vp N918 Vwrite 0 SW  
S1662 Vp N919 Vwrite 0 SW  
S1664 Vp N920 Vwrite 0 SW  
S1666 Vp N921 Vwrite 0 SW  
S1668 Vn N922 Vwrite 0 SW  
S1670 Vn N923 Vwrite 0 SW  
S1672 Vp N924 Vwrite 0 SW  
S1674 Vp N925 Vwrite 0 SW  
S1676 Vp N926 Vwrite 0 SW  
S1678 Vn N927 Vwrite 0 SW  
S1680 Vn N928 Vwrite 0 SW  
S1682 Vp N929 Vwrite 0 SW  
S1684 Vp N930 Vwrite 0 SW  
S1686 Vn N931 Vwrite 0 SW  
S1688 Vp N932 Vwrite 0 SW  
S1690 Vp N933 Vwrite 0 SW  
S1692 Vp N934 Vwrite 0 SW  
S1694 Vn N935 Vwrite 0 SW  
S1696 Vp N936 Vwrite 0 SW  
S1698 Vp N937 Vwrite 0 SW  
S1700 Vp N938 Vwrite 0 SW  
S1702 Vn N939 Vwrite 0 SW  
S1704 Vn N940 Vwrite 0 SW  
S1706 Vn N941 Vwrite 0 SW  
S1708 Vn N942 Vwrite 0 SW  
S1710 Vn N943 Vwrite 0 SW  
S1712 Vp N944 Vwrite 0 SW  
S1713 0 N945 Vwrite 0 SW  
S1714 0 N946 Vwrite 0 SW  
S1715 0 N947 Vwrite 0 SW  
S1716 0 N948 Vwrite 0 SW  
S1717 0 N949 Vwrite 0 SW  
S1718 0 N950 Vwrite 0 SW  
S1719 0 N951 Vwrite 0 SW  
S1720 0 N952 Vwrite 0 SW  
XU793 N945 N881 MScammodel MScammodel  
XU794 N946 N882 MScammodel MScammodel

XU795	N947	N883	MScammodel	MScammodel
XU796	N948	N884	MScammodel	MScammodel
XU797	N949	N885	MScammodel	MScammodel
XU798	N950	N886	MScammodel	MScammodel
XU799	N951	N887	MScammodel	MScammodel
XU800	N952	N888	MScammodel	MScammodel
XU801	N945	N889	MScammodel	MScammodel
XU802	N946	N890	MScammodel	MScammodel
XU803	N947	N891	MScammodel	MScammodel
XU804	N948	N892	MScammodel	MScammodel
XU805	N949	N893	MScammodel	MScammodel
XU806	N950	N894	MScammodel	MScammodel
XU807	N951	N895	MScammodel	MScammodel
XU808	N952	N896	MScammodel	MScammodel
XU809	N945	N897	MScammodel	MScammodel
XU810	N946	N898	MScammodel	MScammodel
XU811	N947	N899	MScammodel	MScammodel
XU812	N948	N900	MScammodel	MScammodel
XU813	N949	N901	MScammodel	MScammodel
XU814	N950	N902	MScammodel	MScammodel
XU815	N951	N903	MScammodel	MScammodel
XU816	N952	N904	MScammodel	MScammodel
XU817	N945	N905	MScammodel	MScammodel
XU818	N946	N906	MScammodel	MScammodel
XU819	N947	N907	MScammodel	MScammodel
XU820	N948	N908	MScammodel	MScammodel
XU821	N949	N909	MScammodel	MScammodel
XU822	N950	N910	MScammodel	MScammodel
XU823	N951	N911	MScammodel	MScammodel
XU824	N952	N912	MScammodel	MScammodel
XU825	N945	N913	MScammodel	MScammodel
XU826	N946	N914	MScammodel	MScammodel
XU827	N947	N915	MScammodel	MScammodel
XU828	N948	N916	MScammodel	MScammodel
XU829	N949	N917	MScammodel	MScammodel
XU830	N950	N918	MScammodel	MScammodel
XU831	N951	N919	MScammodel	MScammodel
XU832	N952	N920	MScammodel	MScammodel
XU833	N945	N921	MScammodel	MScammodel
XU834	N946	N922	MScammodel	MScammodel
XU835	N947	N923	MScammodel	MScammodel
XU836	N948	N924	MScammodel	MScammodel
XU837	N949	N925	MScammodel	MScammodel
XU838	N950	N926	MScammodel	MScammodel
XU839	N951	N927	MScammodel	MScammodel
XU840	N952	N928	MScammodel	MScammodel
XU841	N945	N929	MScammodel	MScammodel
XU842	N946	N930	MScammodel	MScammodel
XU843	N947	N931	MScammodel	MScammodel
XU844	N948	N932	MScammodel	MScammodel
XU845	N949	N933	MScammodel	MScammodel
XU846	N950	N934	MScammodel	MScammodel
XU847	N951	N935	MScammodel	MScammodel
XU848	N952	N936	MScammodel	MScammodel
XU849	N945	N937	MScammodel	MScammodel
XU850	N946	N938	MScammodel	MScammodel
XU851	N947	N939	MScammodel	MScammodel
XU852	N948	N940	MScammodel	MScammodel
XU853	N949	N941	MScammodel	MScammodel
XU854	N950	N942	MScammodel	MScammodel
XU855	N951	N943	MScammodel	MScammodel
XU856	N952	N944	MScammodel	MScammodel
S1721	N945	N953	Vreadcol1	0 SW
S1722	N946	N954	Vreadcol2	0 SW
S1723	N947	N955	Vreadcol3	0 SW
S1724	N948	N956	Vreadcol4	0 SW
S1725	N949	N957	Vreadcol5	0 SW
S1726	N950	N958	Vreadcol6	0 SW
S1727	N951	N959	Vreadcol7	0 SW
S1728	N952	N960	Vreadcol8	0 SW
R89	N953	0	57k	
R90	N954	0	57k	
R91	N955	0	57k	
R92	N956	0	57k	
R93	N957	0	57k	
R94	N958	0	57k	
R95	N959	0	57k	
R96	N960	0	57k	
XU857	N953	Vrefcross	Vcccomp	Vnncomp Voutread121 ua741
XU858	N954	Vrefcross	Vcccomp	Vnncomp Voutread122 ua741
XU859	N955	Vrefcross	Vcccomp	Vnncomp Voutread123 ua741
XU860	N956	Vrefcross	Vcccomp	Vnncomp Voutread124 ua741
XU861	N957	Vrefcross	Vcccomp	Vnncomp Voutread125 ua741
XU862	N958	Vrefcross	Vcccomp	Vnncomp Voutread126 ua741

```
XU863 N959 Vrefcross Vcccomp Vnncomp Voutread127 ua741
XU864 N960 Vrefcross Vcccomp Vnncomp Voutread128 ua741
.tran 0 332u 10u uic
.backanno
.end
```

# Appendix E -SPICE netlist generation code (CAM array)

```
* This is a SPICE code generator for CAM
.model SW SW(Vt=0.5 Roff=1T)
.lib MS.sub
.include tsmc_model_250nm.txt
.lib C:\PROGRA~2\LTC\LTSPIC~1\lib\cmp\standard.mos
.model NMOS NMOS

.options gmin=1e-9
.options abstol=1e-9
.options reltol=0.003
.options cshunt=1e-16

Vcc Vcc 0 1
Vp Vp 0 1
Vn Vn 0 -1
Vwritecam Vwritecam 0 PULSE(0 1 0 1n 1n 3u 10u 1)
Vreadcam Vreadcam 0 PULSE(0 1 10u 1n 1n 3u 10u 1)

C1 Cap1 0 100p IC=0.65
C2 Cap2 0 100p IC=0.65
C3 Cap3 0 100p IC=0.65
C4 Cap4 0 100p IC=0.65
C5 Cap5 0 100p IC=0.65
C6 Cap6 0 100p IC=0.65
C7 Cap7 0 100p IC=0.65
C8 Cap8 0 100p IC=0.65
S11 Cap1 Memin11 Vreadcam 0 SW
S14 Memin11 Memin12 Vreadcam 0 SW
S13 Memout11 0 Vwritecam 0 SW
S16 Memout12 0 Vwritecam 0 SW
XU11 Memin11 Memout11 MSmodel MSmodel
XU12 Memin12 Memout12 MSmodel MSmodel
S12 Memin11 Vn Vwritecam 0 SW
S15 Memin12 Vp Vwritecam 0 SW
M11 Memout11 0 0 0 CMOSN l=250n w=2500n
M12 Memout12 Vreadcam 0 0 CMOSN l=250n w=2500n
S17 Memin12 Memin13 Vreadcam 0 SW
S110 Memin13 Memin14 Vreadcam 0 SW
S19 Memout13 0 Vwritecam 0 SW
S112 Memout14 0 Vwritecam 0 SW
XU13 Memin13 Memout13 MSmodel MSmodel
XU14 Memin14 Memout14 MSmodel MSmodel
S18 Memin13 Vp Vwritecam 0 SW
S111 Memin14 Vn Vwritecam 0 SW
M13 Memout13 0 0 0 CMOSN l=250n w=2500n
M14 Memout14 Vreadcam 0 0 CMOSN l=250n w=2500n
S113 Memin14 Memin15 Vreadcam 0 SW
S116 Memin15 Memin16 Vreadcam 0 SW
S115 Memout15 0 Vwritecam 0 SW
S118 Memout16 0 Vwritecam 0 SW
XU15 Memin15 Memout15 MSmodel MSmodel
XU16 Memin16 Memout16 MSmodel MSmodel
S114 Memin15 Vn Vwritecam 0 SW
S117 Memin16 Vp Vwritecam 0 SW
M15 Memout15 0 0 0 CMOSN l=250n w=2500n
M16 Memout16 Vreadcam 0 0 CMOSN l=250n w=2500n
S119 Memin16 Memin17 Vreadcam 0 SW
S122 Memin17 Memin18 Vreadcam 0 SW
S121 Memout17 0 Vwritecam 0 SW
S124 Memout18 0 Vwritecam 0 SW
XU17 Memin17 Memout17 MSmodel MSmodel
XU18 Memin18 Memout18 MSmodel MSmodel
S120 Memin17 Vn Vwritecam 0 SW
S123 Memin18 Vp Vwritecam 0 SW
M17 Memout17 0 0 0 CMOSN l=250n w=2500n
M18 Memout18 Vreadcam 0 0 CMOSN l=250n w=2500n
S125 Memin18 Memin19 Vreadcam 0 SW
S128 Memin19 Memin110 Vreadcam 0 SW
S127 Memout19 0 Vwritecam 0 SW
S130 Memout110 0 Vwritecam 0 SW
XU19 Memin19 Memout19 MSmodel MSmodel
XU110 Memin110 Memout110 MSmodel MSmodel
S126 Memin19 Vn Vwritecam 0 SW
```

```

S129 Memin110 Vp Vwritecam 0 SW
M19 Memout19 0 0 0 CMOSN l=250n w=2500n
M110 Memout110 Vreadcam 0 0 CMOSN l=250n w=2500n
S131 Memin110 Memin111 Vreadcam 0 SW
S134 Memin111 Memin112 Vreadcam 0 SW
S133 Memout111 0 Vwritecam 0 SW
S136 Memout112 0 Vwritecam 0 SW
XU111 Memin111 Memout111 MSmodel MSmodel
XU112 Memin112 Memout112 MSmodel MSmodel
S132 Memin111 Vn Vwritecam 0 SW
S135 Memin112 Vp Vwritecam 0 SW
M111 Memout111 0 0 0 CMOSN l=250n w=2500n
M112 Memout112 Vreadcam 0 0 CMOSN l=250n w=2500n
S137 Memin112 Memin113 Vreadcam 0 SW
S140 Memin113 Memin114 Vreadcam 0 SW
S139 Memout113 0 Vwritecam 0 SW
S142 Memout114 0 Vwritecam 0 SW
XU113 Memin113 Memout113 MSmodel MSmodel
XU114 Memin114 Memout114 MSmodel MSmodel
S138 Memin113 Vn Vwritecam 0 SW
S141 Memin114 Vp Vwritecam 0 SW
M113 Memout113 0 0 0 CMOSN l=250n w=2500n
M114 Memout114 Vreadcam 0 0 CMOSN l=250n w=2500n
S143 Memin114 Memin115 Vreadcam 0 SW
S146 Memin115 Memin116 Vreadcam 0 SW
S145 Memout115 0 Vwritecam 0 SW
S148 Memout116 0 Vwritecam 0 SW
XU115 Memin115 Memout115 MSmodel MSmodel
XU116 Memin116 Memout116 MSmodel MSmodel
S144 Memin115 Vn Vwritecam 0 SW
S147 Memin116 Vp Vwritecam 0 SW
M115 Memout115 0 0 0 CMOSN l=250n w=2500n
M116 Memout116 Vreadcam 0 0 CMOSN l=250n w=2500n
S21 Cap2 Memin21 Vreadcam 0 SW
S24 Memin21 Memin22 Vreadcam 0 SW
S23 Memout21 0 Vwritecam 0 SW
S26 Memout22 0 Vwritecam 0 SW
XU21 Memin21 Memout21 MSmodel MSmodel
XU22 Memin22 Memout22 MSmodel MSmodel
S22 Memin21 Vn Vwritecam 0 SW
S25 Memin22 Vp Vwritecam 0 SW
M21 Memout21 0 0 0 CMOSN l=250n w=2500n
M22 Memout22 Vreadcam 0 0 CMOSN l=250n w=2500n
S27 Memin22 Memin23 Vreadcam 0 SW
S210 Memin23 Memin24 Vreadcam 0 SW
S29 Memout23 0 Vwritecam 0 SW
S212 Memout24 0 Vwritecam 0 SW
XU23 Memin23 Memout23 MSmodel MSmodel
XU24 Memin24 Memout24 MSmodel MSmodel
S28 Memin23 Vn Vwritecam 0 SW
S211 Memin24 Vp Vwritecam 0 SW
M23 Memout23 0 0 0 CMOSN l=250n w=2500n
M24 Memout24 Vreadcam 0 0 CMOSN l=250n w=2500n
S213 Memin24 Memin25 Vreadcam 0 SW
S216 Memin25 Memin26 Vreadcam 0 SW
S215 Memout25 0 Vwritecam 0 SW
S218 Memout26 0 Vwritecam 0 SW
XU25 Memin25 Memout25 MSmodel MSmodel
XU26 Memin26 Memout26 MSmodel MSmodel
S214 Memin25 Vn Vwritecam 0 SW
S217 Memin26 Vp Vwritecam 0 SW
M25 Memout25 0 0 0 CMOSN l=250n w=2500n
M26 Memout26 Vreadcam 0 0 CMOSN l=250n w=2500n
S219 Memin26 Memin27 Vreadcam 0 SW
S222 Memin27 Memin28 Vreadcam 0 SW
S221 Memout27 0 Vwritecam 0 SW
S224 Memout28 0 Vwritecam 0 SW
XU27 Memin27 Memout27 MSmodel MSmodel
XU28 Memin28 Memout28 MSmodel MSmodel
S220 Memin27 Vn Vwritecam 0 SW
S223 Memin28 Vp Vwritecam 0 SW
M27 Memout27 0 0 0 CMOSN l=250n w=2500n
M28 Memout28 Vreadcam 0 0 CMOSN l=250n w=2500n
S225 Memin28 Memin29 Vreadcam 0 SW
S228 Memin29 Memin210 Vreadcam 0 SW
S227 Memout29 0 Vwritecam 0 SW
S230 Memout210 0 Vwritecam 0 SW
XU29 Memin29 Memout29 MSmodel MSmodel
XU210 Memin210 Memout210 MSmodel MSmodel
S226 Memin29 Vn Vwritecam 0 SW
S229 Memin210 Vp Vwritecam 0 SW
M29 Memout29 0 0 0 CMOSN l=250n w=2500n
M210 Memout210 Vreadcam 0 0 CMOSN l=250n w=2500n
S231 Memin210 Memin211 Vreadcam 0 SW

```

S234 Memin211 Memin212 Vreadcam 0 SW  
S233 Memout211 0 Vwritecam 0 SW  
S236 Memout212 0 Vwritecam 0 SW  
XU211 Memin211 Memout211 MSmodel MSmodel  
XU212 Memin212 Memout212 MSmodel MSmodel  
S232 Memin211 Vn Vwritecam 0 SW  
S235 Memin212 Vp Vwritecam 0 SW  
M211 Memout211 0 0 0 CMOSN l=250n w=2500n  
M212 Memout212 Vreadcam 0 0 CMOSN l=250n w=2500n  
S237 Memin212 Memin213 Vreadcam 0 SW  
S240 Memin213 Memin214 Vreadcam 0 SW  
S239 Memout213 0 Vwritecam 0 SW  
S242 Memout214 0 Vwritecam 0 SW  
XU213 Memin213 Memout213 MSmodel MSmodel  
XU214 Memin214 Memout214 MSmodel MSmodel  
S238 Memin213 Vn Vwritecam 0 SW  
S241 Memin214 Vp Vwritecam 0 SW  
M213 Memout213 0 0 0 CMOSN l=250n w=2500n  
M214 Memout214 Vreadcam 0 0 CMOSN l=250n w=2500n  
S243 Memin214 Memin215 Vreadcam 0 SW  
S246 Memin215 Memin216 Vreadcam 0 SW  
S245 Memout215 0 Vwritecam 0 SW  
S248 Memout216 0 Vwritecam 0 SW  
XU215 Memin215 Memout215 MSmodel MSmodel  
XU216 Memin216 Memout216 MSmodel MSmodel  
S244 Memin215 Vn Vwritecam 0 SW  
S247 Memin216 Vp Vwritecam 0 SW  
M215 Memout215 0 0 0 CMOSN l=250n w=2500n  
M216 Memout216 Vreadcam 0 0 CMOSN l=250n w=2500n  
S31 Cap3 Memin31 Vreadcam 0 SW  
S34 Memin31 Memin32 Vreadcam 0 SW  
S33 Memout31 0 Vwritecam 0 SW  
S36 Memout32 0 Vwritecam 0 SW  
XU31 Memin31 Memout31 MSmodel MSmodel  
XU32 Memin32 Memout32 MSmodel MSmodel  
S32 Memin31 Vn Vwritecam 0 SW  
S35 Memin32 Vp Vwritecam 0 SW  
M31 Memout31 Vreadcam 0 0 CMOSN l=250n w=2500n  
M32 Memout32 0 0 0 CMOSN l=250n w=2500n  
S37 Memin32 Memin33 Vreadcam 0 SW  
S310 Memin33 Memin34 Vreadcam 0 SW  
S39 Memout33 0 Vwritecam 0 SW  
S312 Memout34 0 Vwritecam 0 SW  
XU33 Memin33 Memout33 MSmodel MSmodel  
XU34 Memin34 Memout34 MSmodel MSmodel  
S38 Memin33 Vn Vwritecam 0 SW  
S311 Memin34 Vp Vwritecam 0 SW  
M33 Memout33 0 0 0 CMOSN l=250n w=2500n  
M34 Memout34 Vreadcam 0 0 CMOSN l=250n w=2500n  
S313 Memin34 Memin35 Vreadcam 0 SW  
S316 Memin35 Memin36 Vreadcam 0 SW  
S315 Memout35 0 Vwritecam 0 SW  
S318 Memout36 0 Vwritecam 0 SW  
XU35 Memin35 Memout35 MSmodel MSmodel  
XU36 Memin36 Memout36 MSmodel MSmodel  
S314 Memin35 Vn Vwritecam 0 SW  
S317 Memin36 Vp Vwritecam 0 SW  
M35 Memout35 0 0 0 CMOSN l=250n w=2500n  
M36 Memout36 Vreadcam 0 0 CMOSN l=250n w=2500n  
S319 Memin36 Memin37 Vreadcam 0 SW  
S322 Memin37 Memin38 Vreadcam 0 SW  
S321 Memout37 0 Vwritecam 0 SW  
S324 Memout38 0 Vwritecam 0 SW  
XU37 Memin37 Memout37 MSmodel MSmodel  
XU38 Memin38 Memout38 MSmodel MSmodel  
S320 Memin37 Vn Vwritecam 0 SW  
S323 Memin38 Vp Vwritecam 0 SW  
M37 Memout37 0 0 0 CMOSN l=250n w=2500n  
M38 Memout38 Vreadcam 0 0 CMOSN l=250n w=2500n  
S325 Memin38 Memin39 Vreadcam 0 SW  
S328 Memin39 Memin310 Vreadcam 0 SW  
S327 Memout39 0 Vwritecam 0 SW  
S330 Memout310 0 Vwritecam 0 SW  
XU39 Memin39 Memout39 MSmodel MSmodel  
XU310 Memin310 Memout310 MSmodel MSmodel  
S326 Memin39 Vn Vwritecam 0 SW  
S329 Memin310 Vp Vwritecam 0 SW  
M39 Memout39 0 0 0 CMOSN l=250n w=2500n  
M310 Memout310 Vreadcam 0 0 CMOSN l=250n w=2500n  
S331 Memin310 Memin311 Vreadcam 0 SW  
S334 Memin311 Memin312 Vreadcam 0 SW  
S333 Memout311 0 Vwritecam 0 SW  
S336 Memout312 0 Vwritecam 0 SW  
XU311 Memin311 Memout311 MSmodel MSmodel

XU312 Memin312 Memout312 MSmodel MSmodel  
S332 Memin311 Vn Vwritecam 0 SW  
S335 Memin312 Vp Vwritecam 0 SW  
M311 Memout311 0 0 0 CMOSN l=250n w=2500n  
M312 Memout312 Vreadcam 0 0 CMOSN l=250n w=2500n  
S337 Memin312 Memin313 Vreadcam 0 SW  
S340 Memin313 Memin314 Vreadcam 0 SW  
S339 Memout313 0 Vwritecam 0 SW  
S342 Memout314 0 Vwritecam 0 SW  
XU313 Memin313 Memout313 MSmodel MSmodel  
XU314 Memin314 Memout314 MSmodel MSmodel  
S338 Memin313 Vp Vwritecam 0 SW  
S341 Memin314 Vn Vwritecam 0 SW  
M313 Memout313 0 0 0 CMOSN l=250n w=2500n  
M314 Memout314 Vreadcam 0 0 CMOSN l=250n w=2500n  
S343 Memin314 Memin315 Vreadcam 0 SW  
S346 Memin315 Memin316 Vreadcam 0 SW  
S345 Memout315 0 Vwritecam 0 SW  
S348 Memout316 0 Vwritecam 0 SW  
XU315 Memin315 Memout315 MSmodel MSmodel  
XU316 Memin316 Memout316 MSmodel MSmodel  
S344 Memin315 Vn Vwritecam 0 SW  
S347 Memin316 Vp Vwritecam 0 SW  
M315 Memout315 0 0 0 CMOSN l=250n w=2500n  
M316 Memout316 Vreadcam 0 0 CMOSN l=250n w=2500n  
S41 Cap4 Memin41 Vreadcam 0 SW  
S44 Memin41 Memin42 Vreadcam 0 SW  
S43 Memout41 0 Vwritecam 0 SW  
S46 Memout42 0 Vwritecam 0 SW  
XU41 Memin41 Memout41 MSmodel MSmodel  
XU42 Memin42 Memout42 MSmodel MSmodel  
S42 Memin41 Vn Vwritecam 0 SW  
S45 Memin42 Vp Vwritecam 0 SW  
M41 Memout41 0 0 0 CMOSN l=250n w=2500n  
M42 Memout42 Vreadcam 0 0 CMOSN l=250n w=2500n  
S47 Memin42 Memin43 Vreadcam 0 SW  
S410 Memin43 Memin44 Vreadcam 0 SW  
S49 Memout43 0 Vwritecam 0 SW  
S412 Memout44 0 Vwritecam 0 SW  
XU43 Memin43 Memout43 MSmodel MSmodel  
XU44 Memin44 Memout44 MSmodel MSmodel  
S48 Memin43 Vn Vwritecam 0 SW  
S411 Memin44 Vp Vwritecam 0 SW  
M43 Memout43 0 0 0 CMOSN l=250n w=2500n  
M44 Memout44 Vreadcam 0 0 CMOSN l=250n w=2500n  
S413 Memin44 Memin45 Vreadcam 0 SW  
S416 Memin45 Memin46 Vreadcam 0 SW  
S415 Memout45 0 Vwritecam 0 SW  
S418 Memout46 0 Vwritecam 0 SW  
XU45 Memin45 Memout45 MSmodel MSmodel  
XU46 Memin46 Memout46 MSmodel MSmodel  
S414 Memin45 Vp Vwritecam 0 SW  
S417 Memin46 Vn Vwritecam 0 SW  
M45 Memout45 0 0 0 CMOSN l=250n w=2500n  
M46 Memout46 Vreadcam 0 0 CMOSN l=250n w=2500n  
S419 Memin46 Memin47 Vreadcam 0 SW  
S422 Memin47 Memin48 Vreadcam 0 SW  
S421 Memout47 0 Vwritecam 0 SW  
S424 Memout48 0 Vwritecam 0 SW  
XU47 Memin47 Memout47 MSmodel MSmodel  
XU48 Memin48 Memout48 MSmodel MSmodel  
S420 Memin47 Vn Vwritecam 0 SW  
S423 Memin48 Vp Vwritecam 0 SW  
M47 Memout47 Vreadcam 0 0 CMOSN l=250n w=2500n  
M48 Memout48 0 0 0 CMOSN l=250n w=2500n  
S425 Memin48 Memin49 Vreadcam 0 SW  
S428 Memin49 Memin410 Vreadcam 0 SW  
S427 Memout49 0 Vwritecam 0 SW  
S430 Memout410 0 Vwritecam 0 SW  
XU49 Memin49 Memout49 MSmodel MSmodel  
XU410 Memin410 Memout410 MSmodel MSmodel  
S426 Memin49 Vp Vwritecam 0 SW  
S429 Memin410 Vn Vwritecam 0 SW  
M49 Memout49 Vreadcam 0 0 CMOSN l=250n w=2500n  
M410 Memout410 0 0 0 CMOSN l=250n w=2500n  
S431 Memin410 Memin411 Vreadcam 0 SW  
S434 Memin411 Memin412 Vreadcam 0 SW  
S433 Memout411 0 Vwritecam 0 SW  
S436 Memout412 0 Vwritecam 0 SW  
XU411 Memin411 Memout411 MSmodel MSmodel  
XU412 Memin412 Memout412 MSmodel MSmodel  
S432 Memin411 Vn Vwritecam 0 SW  
S435 Memin412 Vp Vwritecam 0 SW  
M411 Memout411 Vreadcam 0 0 CMOSN l=250n w=2500n

M412 Memout412 0 0 0 CMOSN l=250n w=2500n  
S437 Memin412 Memin413 Vreadcam 0 SW  
S440 Memin413 Memin414 Vreadcam 0 SW  
S439 Memout413 0 Vwritecam 0 SW  
S442 Memout414 0 Vwritecam 0 SW  
XU413 Memin413 Memout413 MSmodel MSmodel  
XU414 Memin414 Memout414 MSmodel MSmodel  
S438 Memin413 Vp Vwritecam 0 SW  
S441 Memin414 Vn Vwritecam 0 SW  
M413 Memout413 0 0 0 CMOSN l=250n w=2500n  
M414 Memout414 Vreadcam 0 0 CMOSN l=250n w=2500n  
S443 Memin414 Memin415 Vreadcam 0 SW  
S446 Memin415 Memin416 Vreadcam 0 SW  
S445 Memout415 0 Vwritecam 0 SW  
S448 Memout416 0 Vwritecam 0 SW  
XU415 Memin415 Memout415 MSmodel MSmodel  
XU416 Memin416 Memout416 MSmodel MSmodel  
S444 Memin415 Vp Vwritecam 0 SW  
S447 Memin416 Vn Vwritecam 0 SW  
M415 Memout415 0 0 0 CMOSN l=250n w=2500n  
M416 Memout416 Vreadcam 0 0 CMOSN l=250n w=2500n  
S51 Cap5 Memin51 Vreadcam 0 SW  
S54 Memin51 Memin52 Vreadcam 0 SW  
S53 Memout51 0 Vwritecam 0 SW  
S56 Memout52 0 Vwritecam 0 SW  
XU51 Memin51 Memout51 MSmodel MSmodel  
XU52 Memin52 Memout52 MSmodel MSmodel  
S52 Memin51 Vn Vwritecam 0 SW  
S55 Memin52 Vp Vwritecam 0 SW  
M51 Memout51 0 0 0 CMOSN l=250n w=2500n  
M52 Memout52 Vreadcam 0 0 CMOSN l=250n w=2500n  
S57 Memin52 Memin53 Vreadcam 0 SW  
S510 Memin53 Memin54 Vreadcam 0 SW  
S59 Memout53 0 Vwritecam 0 SW  
S512 Memout54 0 Vwritecam 0 SW  
XU53 Memin53 Memout53 MSmodel MSmodel  
XU54 Memin54 Memout54 MSmodel MSmodel  
S58 Memin53 Vn Vwritecam 0 SW  
S511 Memin54 Vp Vwritecam 0 SW  
M53 Memout53 0 0 0 CMOSN l=250n w=2500n  
M54 Memout54 Vreadcam 0 0 CMOSN l=250n w=2500n  
S513 Memin54 Memin55 Vreadcam 0 SW  
S516 Memin55 Memin56 Vreadcam 0 SW  
S515 Memout55 0 Vwritecam 0 SW  
S518 Memout56 0 Vwritecam 0 SW  
XU55 Memin55 Memout55 MSmodel MSmodel  
XU56 Memin56 Memout56 MSmodel MSmodel  
S514 Memin55 Vn Vwritecam 0 SW  
S517 Memin56 Vp Vwritecam 0 SW  
M55 Memout55 Vreadcam 0 0 CMOSN l=250n w=2500n  
M56 Memout56 0 0 0 CMOSN l=250n w=2500n  
S519 Memin56 Memin57 Vreadcam 0 SW  
S522 Memin57 Memin58 Vreadcam 0 SW  
S521 Memout57 0 Vwritecam 0 SW  
S524 Memout58 0 Vwritecam 0 SW  
XU57 Memin57 Memout57 MSmodel MSmodel  
XU58 Memin58 Memout58 MSmodel MSmodel  
S520 Memin57 Vn Vwritecam 0 SW  
S523 Memin58 Vp Vwritecam 0 SW  
M57 Memout57 Vreadcam 0 0 CMOSN l=250n w=2500n  
M58 Memout58 0 0 0 CMOSN l=250n w=2500n  
S525 Memin58 Memin59 Vreadcam 0 SW  
S528 Memin59 Memin510 Vreadcam 0 SW  
S527 Memout59 0 Vwritecam 0 SW  
S530 Memout510 0 Vwritecam 0 SW  
XU59 Memin59 Memout59 MSmodel MSmodel  
XU510 Memin510 Memout510 MSmodel MSmodel  
S526 Memin59 Vp Vwritecam 0 SW  
S529 Memin510 Vn Vwritecam 0 SW  
M59 Memout59 0 0 0 CMOSN l=250n w=2500n  
M510 Memout510 Vreadcam 0 0 CMOSN l=250n w=2500n  
S531 Memin510 Memin511 Vreadcam 0 SW  
S534 Memin511 Memin512 Vreadcam 0 SW  
S533 Memout511 0 Vwritecam 0 SW  
S536 Memout512 0 Vwritecam 0 SW  
XU511 Memin511 Memout511 MSmodel MSmodel  
XU512 Memin512 Memout512 MSmodel MSmodel  
S532 Memin511 Vp Vwritecam 0 SW  
S535 Memin512 Vn Vwritecam 0 SW  
M511 Memout511 0 0 0 CMOSN l=250n w=2500n  
M512 Memout512 Vreadcam 0 0 CMOSN l=250n w=2500n  
S537 Memin512 Memin513 Vreadcam 0 SW  
S540 Memin513 Memin514 Vreadcam 0 SW  
S539 Memout513 0 Vwritecam 0 SW

S542 Memout514 0 Vwritecam 0 SW  
XU513 Memin513 Memout513 MSmodel MSmodel  
XU514 Memin514 Memout514 MSmodel MSmodel  
S538 Memin513 Vn Vwritecam 0 SW  
S541 Memin514 Vp Vwritecam 0 SW  
M513 Memout513 Vreadcam 0 0 CMOSN l=250n w=2500n  
M514 Memout514 0 0 0 CMOSN l=250n w=2500n  
S543 Memin514 Memin515 Vreadcam 0 SW  
S546 Memin515 Memin516 Vreadcam 0 SW  
S545 Memout515 0 Vwritecam 0 SW  
S548 Memout516 0 Vwritecam 0 SW  
XU515 Memin515 Memout515 MSmodel MSmodel  
XU516 Memin516 Memout516 MSmodel MSmodel  
S544 Memin515 Vp Vwritecam 0 SW  
S547 Memin516 Vn Vwritecam 0 SW  
M515 Memout515 0 0 0 CMOSN l=250n w=2500n  
M516 Memout516 Vreadcam 0 0 CMOSN l=250n w=2500n  
S61 Cap6 Memin61 Vreadcam 0 SW  
S64 Memin61 Memin62 Vreadcam 0 SW  
S63 Memout61 0 Vwritecam 0 SW  
S66 Memout62 0 Vwritecam 0 SW  
XU61 Memin61 Memout61 MSmodel MSmodel  
XU62 Memin62 Memout62 MSmodel MSmodel  
S62 Memin61 Vn Vwritecam 0 SW  
S65 Memin62 Vp Vwritecam 0 SW  
M61 Memout61 0 0 0 CMOSN l=250n w=2500n  
M62 Memout62 Vreadcam 0 0 CMOSN l=250n w=2500n  
S67 Memin62 Memin63 Vreadcam 0 SW  
S610 Memin63 Memin64 Vreadcam 0 SW  
S69 Memout63 0 Vwritecam 0 SW  
S612 Memout64 0 Vwritecam 0 SW  
XU63 Memin63 Memout63 MSmodel MSmodel  
XU64 Memin64 Memout64 MSmodel MSmodel  
S68 Memin63 Vn Vwritecam 0 SW  
S611 Memin64 Vp Vwritecam 0 SW  
M63 Memout63 0 0 0 CMOSN l=250n w=2500n  
M64 Memout64 Vreadcam 0 0 CMOSN l=250n w=2500n  
S613 Memin64 Memin65 Vreadcam 0 SW  
S616 Memin65 Memin66 Vreadcam 0 SW  
S615 Memout65 0 Vwritecam 0 SW  
S618 Memout66 0 Vwritecam 0 SW  
XU65 Memin65 Memout65 MSmodel MSmodel  
XU66 Memin66 Memout66 MSmodel MSmodel  
S614 Memin65 Vn Vwritecam 0 SW  
S617 Memin66 Vp Vwritecam 0 SW  
M65 Memout65 Vreadcam 0 0 CMOSN l=250n w=2500n  
M66 Memout66 0 0 0 CMOSN l=250n w=2500n  
S619 Memin66 Memin67 Vreadcam 0 SW  
S622 Memin67 Memin68 Vreadcam 0 SW  
S621 Memout67 0 Vwritecam 0 SW  
S624 Memout68 0 Vwritecam 0 SW  
XU67 Memin67 Memout67 MSmodel MSmodel  
XU68 Memin68 Memout68 MSmodel MSmodel  
S620 Memin67 Vn Vwritecam 0 SW  
S623 Memin68 Vp Vwritecam 0 SW  
M67 Memout67 Vreadcam 0 0 CMOSN l=250n w=2500n  
M68 Memout68 0 0 0 CMOSN l=250n w=2500n  
S625 Memin68 Memin69 Vreadcam 0 SW  
S628 Memin69 Memin610 Vreadcam 0 SW  
S627 Memout69 0 Vwritecam 0 SW  
S630 Memout610 0 Vwritecam 0 SW  
XU69 Memin69 Memout69 MSmodel MSmodel  
XU610 Memin610 Memout610 MSmodel MSmodel  
S626 Memin69 Vp Vwritecam 0 SW  
S629 Memin610 Vn Vwritecam 0 SW  
M69 Memout69 Vreadcam 0 0 CMOSN l=250n w=2500n  
M610 Memout610 0 0 0 CMOSN l=250n w=2500n  
S631 Memin610 Memin611 Vreadcam 0 SW  
S634 Memin611 Memin612 Vreadcam 0 SW  
S633 Memout611 0 Vwritecam 0 SW  
S636 Memout612 0 Vwritecam 0 SW  
XU611 Memin611 Memout611 MSmodel MSmodel  
XU612 Memin612 Memout612 MSmodel MSmodel  
S632 Memin611 Vp Vwritecam 0 SW  
S635 Memin612 Vn Vwritecam 0 SW  
M611 Memout611 0 0 0 CMOSN l=250n w=2500n  
M612 Memout612 Vreadcam 0 0 CMOSN l=250n w=2500n  
S637 Memin612 Memin613 Vreadcam 0 SW  
S640 Memin613 Memin614 Vreadcam 0 SW  
S639 Memout613 0 Vwritecam 0 SW  
S642 Memout614 0 Vwritecam 0 SW  
XU613 Memin613 Memout613 MSmodel MSmodel  
XU614 Memin614 Memout614 MSmodel MSmodel  
S638 Memin613 Vp Vwritecam 0 SW

S641 Memin614 Vn Vwritecam 0 SW  
M613 Memout613 Vreadcam 0 0 CMOSN l=250n w=2500n  
M614 Memout614 0 0 0 CMOSN l=250n w=2500n  
S643 Memin614 Memin615 Vreadcam 0 SW  
S646 Memin615 Memin616 Vreadcam 0 SW  
S645 Memout615 0 Vwritecam 0 SW  
S648 Memout616 0 Vwritecam 0 SW  
XU615 Memin615 Memout615 MSmodel MSmodel  
XU616 Memin616 Memout616 MSmodel MSmodel  
S644 Memin615 Vn Vwritecam 0 SW  
S647 Memin616 Vp Vwritecam 0 SW  
M615 Memout615 0 0 0 CMOSN l=250n w=2500n  
M616 Memout616 Vreadcam 0 0 CMOSN l=250n w=2500n  
S71 Cap7 Memin71 Vreadcam 0 SW  
S74 Memin71 Memin72 Vreadcam 0 SW  
S73 Memout71 0 Vwritecam 0 SW  
S76 Memout72 0 Vwritecam 0 SW  
XU71 Memin71 Memout71 MSmodel MSmodel  
XU72 Memin72 Memout72 MSmodel MSmodel  
S72 Memin71 Vn Vwritecam 0 SW  
S75 Memin72 Vp Vwritecam 0 SW  
M71 Memout71 0 0 0 CMOSN l=250n w=2500n  
M72 Memout72 Vreadcam 0 0 CMOSN l=250n w=2500n  
S77 Memin72 Memin73 Vreadcam 0 SW  
S710 Memin73 Memin74 Vreadcam 0 SW  
S79 Memout73 0 Vwritecam 0 SW  
S712 Memout74 0 Vwritecam 0 SW  
XU73 Memin73 Memout73 MSmodel MSmodel  
XU74 Memin74 Memout74 MSmodel MSmodel  
S78 Memin73 Vn Vwritecam 0 SW  
S711 Memin74 Vp Vwritecam 0 SW  
M73 Memout73 0 0 0 CMOSN l=250n w=2500n  
M74 Memout74 Vreadcam 0 0 CMOSN l=250n w=2500n  
S713 Memin74 Memin75 Vreadcam 0 SW  
S716 Memin75 Memin76 Vreadcam 0 SW  
S715 Memout75 0 Vwritecam 0 SW  
S718 Memout76 0 Vwritecam 0 SW  
XU75 Memin75 Memout75 MSmodel MSmodel  
XU76 Memin76 Memout76 MSmodel MSmodel  
S714 Memin75 Vn Vwritecam 0 SW  
S717 Memin76 Vp Vwritecam 0 SW  
M75 Memout75 Vreadcam 0 0 CMOSN l=250n w=2500n  
M76 Memout76 0 0 0 CMOSN l=250n w=2500n  
S719 Memin76 Memin77 Vreadcam 0 SW  
S722 Memin77 Memin78 Vreadcam 0 SW  
S721 Memout77 0 Vwritecam 0 SW  
S724 Memout78 0 Vwritecam 0 SW  
XU77 Memin77 Memout77 MSmodel MSmodel  
XU78 Memin78 Memout78 MSmodel MSmodel  
S720 Memin77 Vn Vwritecam 0 SW  
S723 Memin78 Vp Vwritecam 0 SW  
M77 Memout77 Vreadcam 0 0 CMOSN l=250n w=2500n  
M78 Memout78 0 0 0 CMOSN l=250n w=2500n  
S725 Memin78 Memin79 Vreadcam 0 SW  
S728 Memin79 Memin710 Vreadcam 0 SW  
S727 Memout79 0 Vwritecam 0 SW  
S730 Memout710 0 Vwritecam 0 SW  
XU79 Memin79 Memout79 MSmodel MSmodel  
XU710 Memin710 Memout710 MSmodel MSmodel  
S726 Memin79 Vn Vwritecam 0 SW  
S729 Memin710 Vp Vwritecam 0 SW  
M79 Memout79 Vreadcam 0 0 CMOSN l=250n w=2500n  
M710 Memout710 0 0 0 CMOSN l=250n w=2500n  
S731 Memin710 Memin711 Vreadcam 0 SW  
S734 Memin711 Memin712 Vreadcam 0 SW  
S733 Memout711 0 Vwritecam 0 SW  
S736 Memout712 0 Vwritecam 0 SW  
XU711 Memin711 Memout711 MSmodel MSmodel  
XU712 Memin712 Memout712 MSmodel MSmodel  
S732 Memin711 Vn Vwritecam 0 SW  
S735 Memin712 Vp Vwritecam 0 SW  
M711 Memout711 Vreadcam 0 0 CMOSN l=250n w=2500n  
M712 Memout712 0 0 0 CMOSN l=250n w=2500n  
S737 Memin712 Memin713 Vreadcam 0 SW  
S740 Memin713 Memin714 Vreadcam 0 SW  
S739 Memout713 0 Vwritecam 0 SW  
S742 Memout714 0 Vwritecam 0 SW  
XU713 Memin713 Memout713 MSmodel MSmodel  
XU714 Memin714 Memout714 MSmodel MSmodel  
S738 Memin713 Vn Vwritecam 0 SW  
S741 Memin714 Vp Vwritecam 0 SW  
M713 Memout713 Vreadcam 0 0 CMOSN l=250n w=2500n  
M714 Memout714 0 0 0 CMOSN l=250n w=2500n  
S743 Memin714 Memin715 Vreadcam 0 SW

S746 Memin715 Memin716 Vreadcam 0 SW  
S745 Memout715 0 Vwritecam 0 SW  
S748 Memout716 0 Vwritecam 0 SW  
XU715 Memin715 Memout715 MSmodel MSmodel  
XU716 Memin716 Memout716 MSmodel MSmodel  
S744 Memin715 Vn Vwritecam 0 SW  
S747 Memin716 Vp Vwritecam 0 SW  
M715 Memout715 0 0 CMOSN l=250n w=2500n  
M716 Memout716 Vreadcam 0 0 CMOSN l=250n w=2500n  
S81 Cap8 Memin81 Vreadcam 0 SW  
S84 Memin81 Memin82 Vreadcam 0 SW  
S83 Memout81 0 Vwritecam 0 SW  
S86 Memout82 0 Vwritecam 0 SW  
XU81 Memin81 Memout81 MSmodel MSmodel  
XU82 Memin82 Memout82 MSmodel MSmodel  
S82 Memin81 Vn Vwritecam 0 SW  
S85 Memin82 Vp Vwritecam 0 SW  
M81 Memout81 0 0 CMOSN l=250n w=2500n  
M82 Memout82 Vreadcam 0 0 CMOSN l=250n w=2500n  
S87 Memin82 Memin83 Vreadcam 0 SW  
S810 Memin83 Memin84 Vreadcam 0 SW  
S89 Memout83 0 Vwritecam 0 SW  
S812 Memout84 0 Vwritecam 0 SW  
XU83 Memin83 Memout83 MSmodel MSmodel  
XU84 Memin84 Memout84 MSmodel MSmodel  
S88 Memin83 Vn Vwritecam 0 SW  
S811 Memin84 Vp Vwritecam 0 SW  
M83 Memout83 0 0 CMOSN l=250n w=2500n  
M84 Memout84 Vreadcam 0 0 CMOSN l=250n w=2500n  
S813 Memin84 Memin85 Vreadcam 0 SW  
S816 Memin85 Memin86 Vreadcam 0 SW  
S815 Memout85 0 Vwritecam 0 SW  
S818 Memout86 0 Vwritecam 0 SW  
XU85 Memin85 Memout85 MSmodel MSmodel  
XU86 Memin86 Memout86 MSmodel MSmodel  
S814 Memin85 Vn Vwritecam 0 SW  
S817 Memin86 Vp Vwritecam 0 SW  
M85 Memout85 0 0 CMOSN l=250n w=2500n  
M86 Memout86 Vreadcam 0 0 CMOSN l=250n w=2500n  
S819 Memin86 Memin87 Vreadcam 0 SW  
S822 Memin87 Memin88 Vreadcam 0 SW  
S821 Memout87 0 Vwritecam 0 SW  
S824 Memout88 0 Vwritecam 0 SW  
XU87 Memin87 Memout87 MSmodel MSmodel  
XU88 Memin88 Memout88 MSmodel MSmodel  
S820 Memin87 Vn Vwritecam 0 SW  
S823 Memin88 Vp Vwritecam 0 SW  
M87 Memout87 Vreadcam 0 0 CMOSN l=250n w=2500n  
M88 Memout88 0 0 CMOSN l=250n w=2500n  
S825 Memin88 Memin89 Vreadcam 0 SW  
S828 Memin89 Memin810 Vreadcam 0 SW  
S827 Memout89 0 Vwritecam 0 SW  
S830 Memout810 0 Vwritecam 0 SW  
XU89 Memin89 Memout89 MSmodel MSmodel  
XU810 Memin810 Memout810 MSmodel MSmodel  
S826 Memin89 Vn Vwritecam 0 SW  
S829 Memin810 Vp Vwritecam 0 SW  
M89 Memout89 Vreadcam 0 0 CMOSN l=250n w=2500n  
M810 Memout810 0 0 CMOSN l=250n w=2500n  
S831 Memin810 Memin811 Vreadcam 0 SW  
S834 Memin811 Memin812 Vreadcam 0 SW  
S833 Memout811 0 Vwritecam 0 SW  
S836 Memout812 0 Vwritecam 0 SW  
XU811 Memin811 Memout811 MSmodel MSmodel  
XU812 Memin812 Memout812 MSmodel MSmodel  
S832 Memin811 Vn Vwritecam 0 SW  
S835 Memin812 Vp Vwritecam 0 SW  
M811 Memout811 Vreadcam 0 0 CMOSN l=250n w=2500n  
M812 Memout812 0 0 CMOSN l=250n w=2500n  
S837 Memin812 Memin813 Vreadcam 0 SW  
S840 Memin813 Memin814 Vreadcam 0 SW  
S839 Memout813 0 Vwritecam 0 SW  
S842 Memout814 0 Vwritecam 0 SW  
XU813 Memin813 Memout813 MSmodel MSmodel  
XU814 Memin814 Memout814 MSmodel MSmodel  
S838 Memin813 Vn Vwritecam 0 SW  
S841 Memin814 Vp Vwritecam 0 SW  
M813 Memout813 0 0 CMOSN l=250n w=2500n  
M814 Memout814 Vreadcam 0 0 CMOSN l=250n w=2500n  
S843 Memin814 Memin815 Vreadcam 0 SW  
S846 Memin815 Memin816 Vreadcam 0 SW  
S845 Memout815 0 Vwritecam 0 SW  
S848 Memout816 0 Vwritecam 0 SW  
XU815 Memin815 Memout815 MSmodel MSmodel

```
XU816 Memin816 Memout816 MSmodel MSmodel
S844 Memin815 Vn Vwritecam 0 SW
S847 Memin816 Vp Vwritecam 0 SW
M815 Memout815 0 0 0 CMOSN l=250n w=2500n
M816 Memout816 Vreadcam 0 0 CMOSN l=250n w=2500n
.tran 0 10.1u 10u uic
.backanno
.end
```